

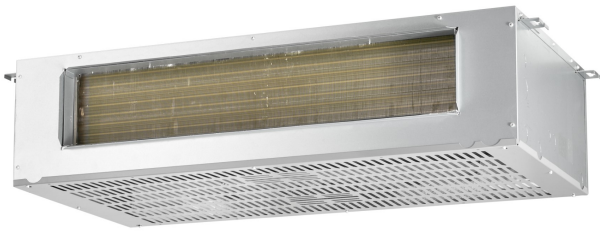

Model Number: AUO18-30N2-M3 / AUP-30N2-JM3

Location: \_\_\_\_\_  
 Engineer: \_\_\_\_\_  
 Submitted to: \_\_\_\_\_  
 Submitted by: \_\_\_\_\_  
 Reference: \_\_\_\_\_

Approval: \_\_\_\_\_  
 Date: \_\_\_\_\_  
 Construction: \_\_\_\_\_  
 Unit #: \_\_\_\_\_  
 Drawing #: \_\_\_\_\_



INDOOR SPECIFICATION		
ESP(in.W.G)		0-0.8
Indoor Air Flow (Turbo/H/M/L/Si) (CFM)		989 / 895 / 806 / 542 / 542
Indoor Noise Level (Turbo/H/M/L/Si)		61 / 61 / 59 / 50 / 50
Dimension (W×D×H)	inch	55-1/4 x 23-3/8 x 11
	mm	1403 × 593 × 278
Package (W×D×H)	inch	59-1/4 x 26-3/4 x 13-5/8
	mm	1505 × 680 × 345
Net/Gross Weight	lbs	139 / 151
	kg	63 / 68.5

OUTDOOR SPECIFICATION		
Compressor Type		ROTARY
Refrigerant		R454B
Factory Charge		670ml
Refrigerant Oil		VG74
Outdoor Air Flow (Max) (CFM)		3,002
Outdoor Noise Level (dBA)		59
Dimension (W×D×H)	inch	37-1/4 x 16-1/8 x 31-7/8
	mm	946 × 410 × 810
Package (W×D×H)	inch	42-7/8 x 19-5/8 x 34-7/8
	mm	1090 × 500 × 885
Net/Gross Weight	lbs	142 / 152
	kg	64.3 / 69.1

EFFICIENCY			
Cooling		Heating	
SEER2	16.6	HSPF2-4	8.1
EER2	10.5	COP	3.2

PERFORMANCE of Cooling	
Cooling (Btu/hr)	
Rated Capacity	30,000
Min/Max Capacity	7,300~33,400
Moisture Removal	2.66
Standard Operating Range	-13°F~-122°F (-25°C~50°C)

Rated Cooling Conditions: Indoor: 80°F DB/67°F WB  
 Outdoor: 95°F DB/75°F WB

PERFORMANCE of Heating	
Heating (Btu/hr)	
1. @ 47°F Rated (Min/Max)	30000(5700~31000)
2. @ 17°F Rated	19,000
3. @ 5°F Max: Capacity / COP	19,000/1.9
Standard Operating Range	-13°F ~75°F (-25°C~24°C)

1. Rated Heating Conditions: Indoor: 70°F DB/60°F WB  
 Outdoor: 47°F DB/43°F WB  
 2. Rated Heating Conditions: Indoor: 70°F DB/60°F WB  
 Outdoor: 17°F DB/15°F WB  
 3. Heating Conditions, Compressor Operating at Max. Frequency Indoor: 70°F DB/60°F WB  
 Outdoor: 5°F DB/5°F WB

ELECTRICAL	
Indoor Power Supply	115/208/230,60Hz,1Ph
Indoor MCA 115V/(208/230V)	115V:8A;208/230V:6A
Indoor MOP	15
Outdoor Power Supply	208/230,60Hz,1Ph
Outdoor MCA	22.5
Outdoor MOP	25.0
Communication Wiring	AWG 20/2
Compressor RLA	17
Outdoor Fan Motor RLA	1.1
Outdoor Fan Motor W	120
Indoor Fan Motor RLA	115V:6.4A;208/230V:4.5A
Indoor Fan Motor W	375
System Power Input @ Cooling (W)	2,857(500 ~ 3,130)
System Power Input @ Heating (W)	2,748(485 ~2,748)
MCA: Min. circuit amps (A)	MOCP: Max. over current protection (A)
RLA: Rated load amps (A)	W: Fan motor rated output (W)

PIPING	
Liquid Size	3/8in (9.52mm)
Gas Size	3/4in (19mm)
Drain Size	5/8in (15.88mm)
Max. Piping Length	246ft (75m)
Max. Height Difference	98ft (30m)
Max. Pre-charged Length	25ft (7.5m)
Refrigerant Pre-charged Amount	92oz (2600g)
Additional Charge of Refrigerant	0.7oz/ft (65g/m)
Connection Method	Flared

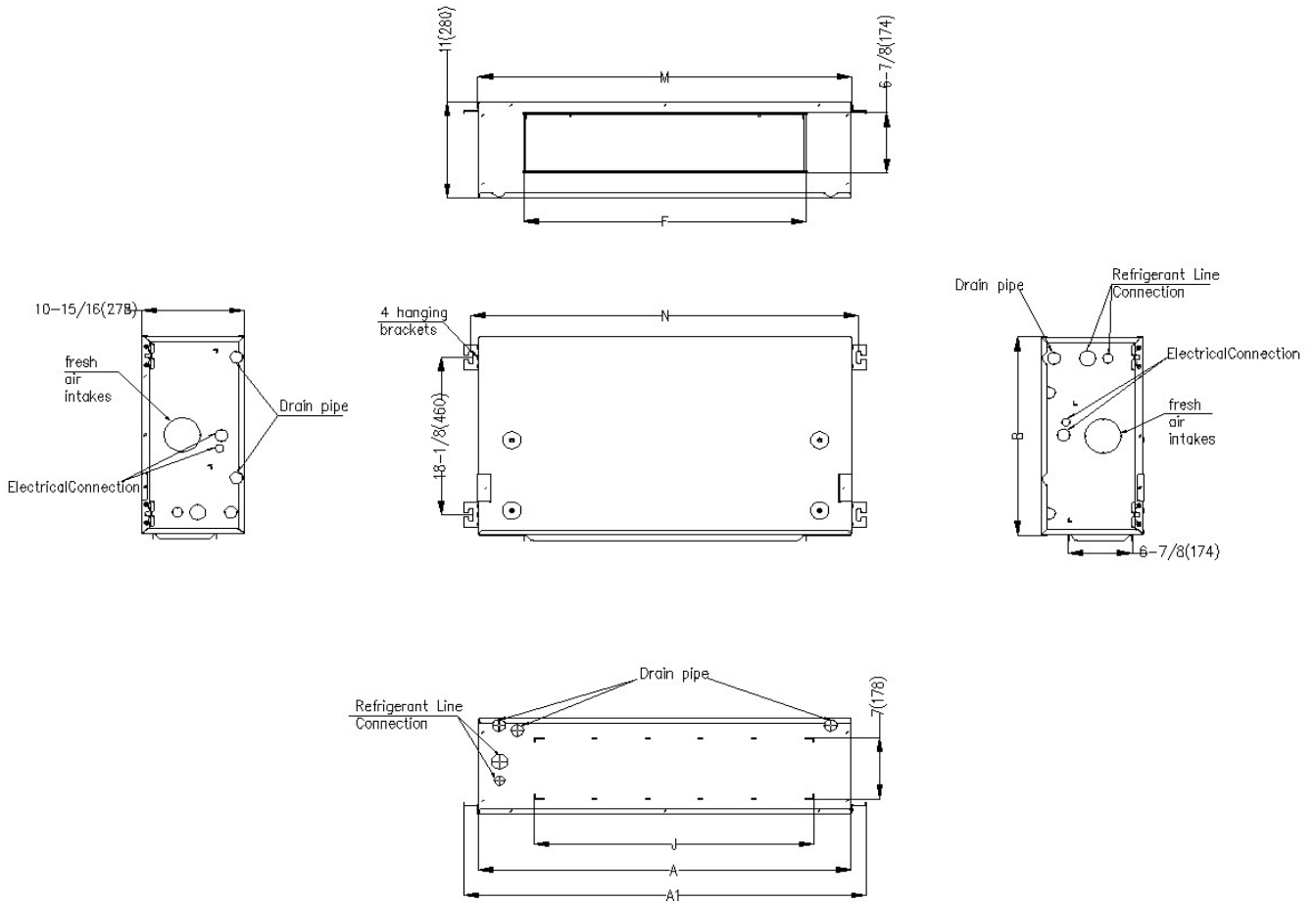

	18K		24K		30K		36K	
	inch	mm	inch	mm	inch	mm	inch	mm
A	39-15/16	1015	45-7/8	1165	51-15/16	1320	58-7/8	1495
A1	43-1/4	1098	49-1/8	1248	55-1/4	1403	62-1/8	1578
J	30	761	35-7/8	911	41-15/16	1066	48-7/8	1241
D	41-5/8	1057	47-1/2	1207	53-5/8	1362	60-1/2	1537
F	30-1/4	769	36-3/16	919	42-5/16	1074	49-3/16	1249
H	36-5/8	930	39-3/4	1010	47-5/8	1210	53-15/16	1370
M	40-3/16	1020	46-1/16	1170	52-3/16	1325	59-1/16	1500
N	41-5/8	1057	40-7/16	1027	53-5/8	1362	60 1/2	1537

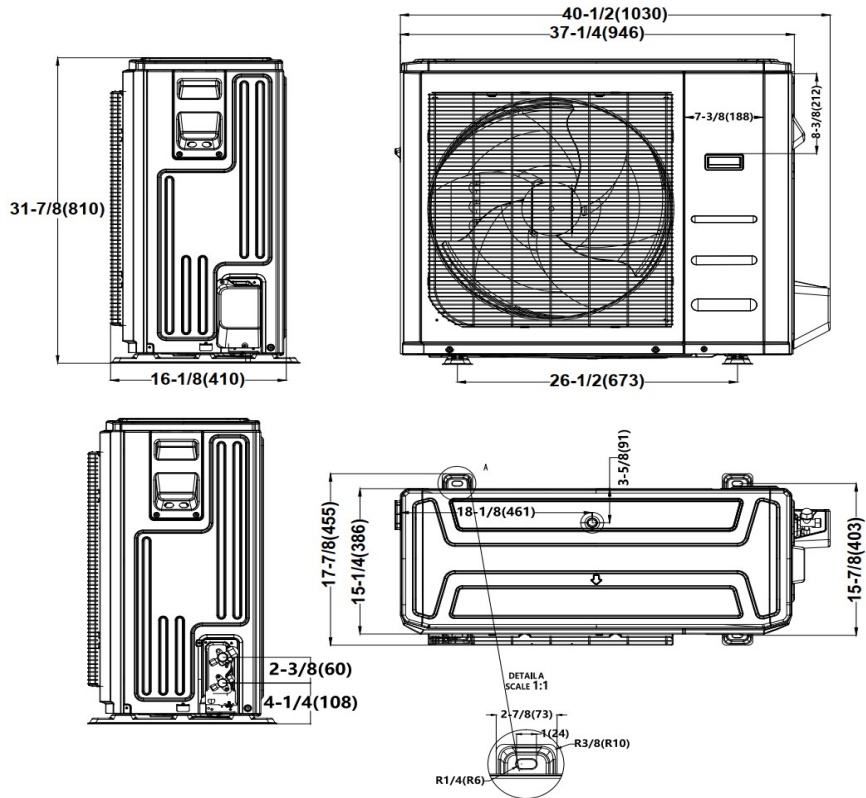

Installation Instruction

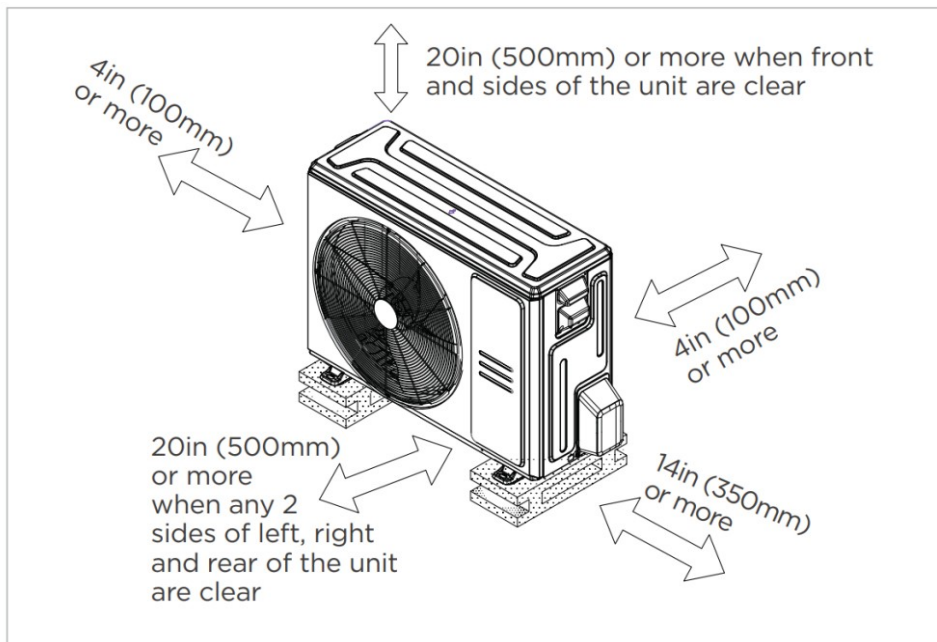

☑ Meets all special requirements shown in Installation Clearance Requirements above.

# 30K

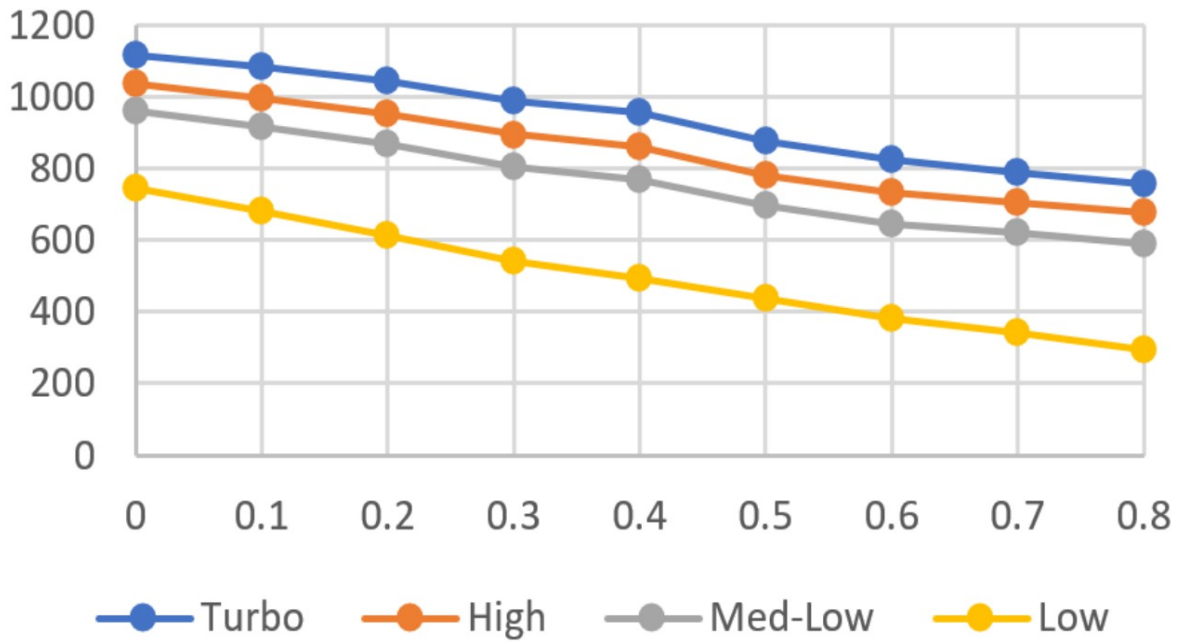

## Features

- High efficiency up to 16.8 SEER2, 12 EER2, 10.5 HSPF2
- Aluminum Coil
- IDU compatible with 115V and 230V
- Constantly Air Flow system up to 0.80 In.W.G
- Optional Auxiliary heat kit up to 10kW
- Easy Maintenance
- Multiple control options available:
  - Two way communication wired controller:120N(X6)
  - Two way communication wired controller with built-in WiFi:120N(X6W)
  - Wireless remote controller
  - Third-Party 24V Thermostat
- Adaptive Control wiring method on 24V and RS485
- Downward or Backward (optional) air inlet
- Chassis heater and crankcase heater equipped as standard