

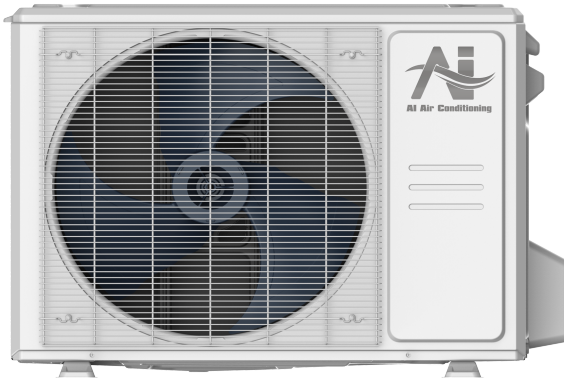

Model Number: AUO18-24N2-M3 / AUP-24N2-IM3

Location: _____
 Engineer: _____
 Submitted to: _____
 Submitted by: _____
 Reference: _____

Approval: _____
 Date: _____
 Construction: _____
 Unit #: _____
 Drawing #: _____

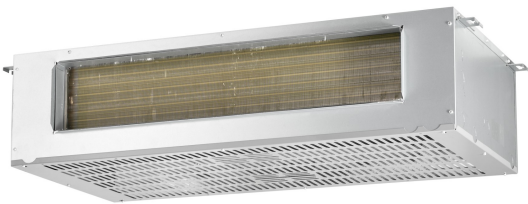

INDOOR SPECIFICATION		
ESP(in.W.G)		0-0.8
Indoor Air Flow (Turbo/H/M/L/Si) (CFM)		824 / 759 / 647 / 630 / 630
Indoor Noise Level (Turbo/H/M/L/Si)		57 / 57 / 54 / 52 / 52
Dimension (W×D×H)	inch	49-1/8 x 23-3/8 x 11
	mm	1248 x 593 x 278
Package (W×D×H)	inch	53-1/8 x 26-3/4 x 13-5/8
	mm	1350 x 680 x 345
Net/Gross Weight	lbs	128 / 139
	kg	58 / 63

OUTDOOR SPECIFICATION		
Compressor Type		ROTARY
Refrigerant		R454B
Factory Charge		620ml
Refrigerant Oil		VG74
Outdoor Air Flow (Max) (CFM)		1,766
Outdoor Noise Level (dBA)		59
Dimension (W×D×H)	inch	35 x 13-1/2 x 26-1/2
	mm	890 x 342 x 673
Package (W×D×H)	inch	39-1/8 x 15-5/8 x 29-1/8
	mm	995 x 398 x 740
Net/Gross Weight	lbs	102 / 109
	kg	46.4 / 49.5

EFFICIENCY			
Cooling		Heating	
SEER2	16.0	HSPF2-4	9.0
EER2	10.0	COP	3.5

PERFORMANCE of Cooling	
Cooling (Btu/hr)	
Rated Capacity	24,000
Min/Max Capacity	7,400~27,000
Moisture Removal	1.91
Standard Operating Range	-13°F~122°F (-25°C~50°C)
Rated Cooling Conditions:	Indoor: 80°F DB/67°F WB Outdoor: 95°F DB/75°F WB

PERFORMANCE of Heating	
Heating (Btu/hr)	
1. @ 47°F Rated (Min/Max)	25000(9200~32,200)
2. @ 17°F Rated	19,800
3. @ 5°F Max: Capacity / COP	19,000/1.8
Standard Operating Range	-13°F ~75°F (-25°C~24°C)
1. Rated Heating Conditions:	Indoor: 70°F DB/60°F WB Outdoor: 47°F DB/43°F WB
2. Rated Heating Conditions:	Indoor: 70°F DB/60°F WB Outdoor: 17°F DB/15°F WB
3. Heating Conditions, Compressor Operating at Max. Frequency	Indoor: 70°F DB/60°F WB Outdoor: 5°F DB/5°F WB

ELECTRICAL	
Indoor Power Supply	115/208/230,60Hz,1Ph
Indoor MCA 115V/(208/230V)	115V:7;208/230V:5
Indoor MOP	15
Outdoor Power Supply	208/230,60Hz,1Ph
Outdoor MCA	19.0
Outdoor MOP	20
Communication Wiring	AWG 20/2
Compressor RLA	14
Outdoor Fan Motor RLA	1
Outdoor Fan Motor W	80
Indoor Fan Motor RLA	115V:5.5;208/230V:3.5
Indoor Fan Motor W	250
System Power Input @ Cooling (W)	2,400(700 ~ 2,900)
System Power Input @ Heating (W)	2,123(600 ~2,750)
MCA: Min. circuit amps (A)	MOCP: Max. over current protection (A)
RLA: Rated load amps (A)	W: Fan motor rated output (W)

PIPING	
Liquid Size	3/8in (9.52mm)
Gas Size	3/4in (19mm)
Drain Size	5/8in (15.88mm)
Max. Piping Length	164ft (50m)
Max. Height Difference	82ft (25m)
Max. Pre-charged Length	25ft (7.5m)
Refrigerant Pre-charged Amount	74oz (2100g)
Additional Charge of Refrigerant	0.7oz/ft (65g/m)
Connection Method	Flared

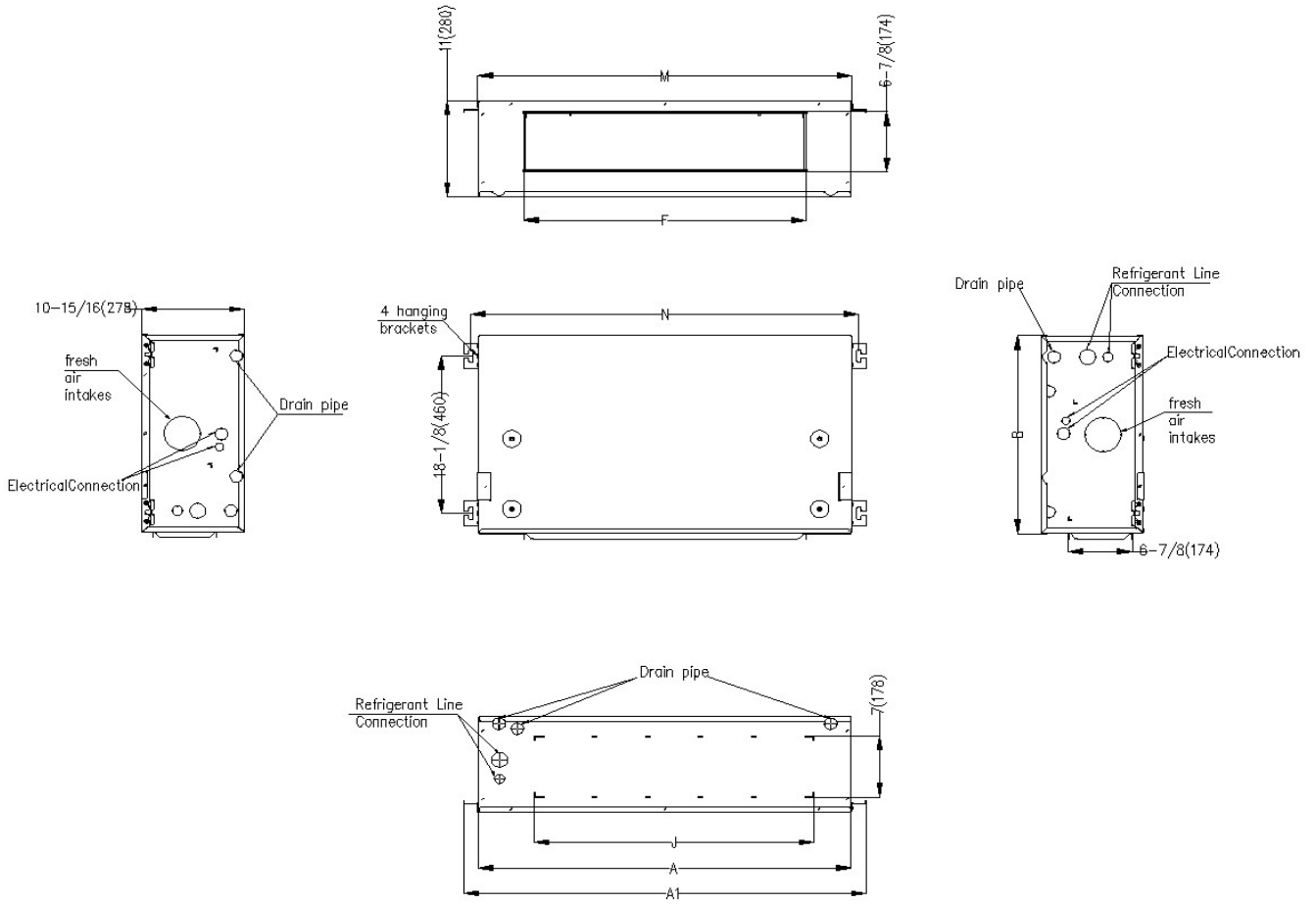

	18K		24K		30K		36K	
	inch	mm	inch	mm	inch	mm	inch	mm
A	39-15/16	1015	45-7/8	1165	51-15/16	1320	58-7/8	1495
A1	43-1/4	1098	49-1/8	1248	55-1/4	1403	62-1/8	1578
J	30	761	35-7/8	911	41-15/16	1066	48-7/8	1241
D	41-5/8	1057	47-1/2	1207	53-5/8	1362	60-1/2	1537
F	30-1/4	769	36-3/16	919	42-5/16	1074	49-3/16	1249
H	36-5/8	930	39-3/4	1010	47-5/8	1210	53-15/16	1370
M	40-3/16	1020	46-1/16	1170	52-3/16	1325	59-1/16	1500
N	41-5/8	1057	40-7/16	1027	53-5/8	1362	60 1/2	1537

Outdoor Unit Dimension

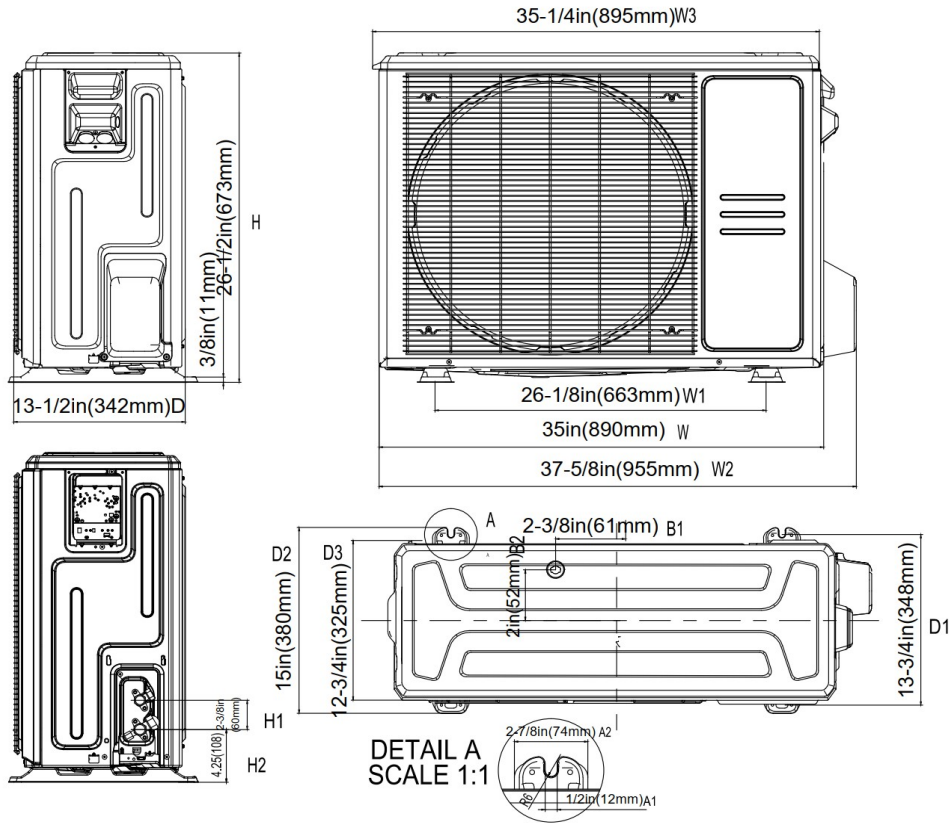

Installation Instruction



Meets all special requirements shown in Installation Clearance Requirements above.

24K

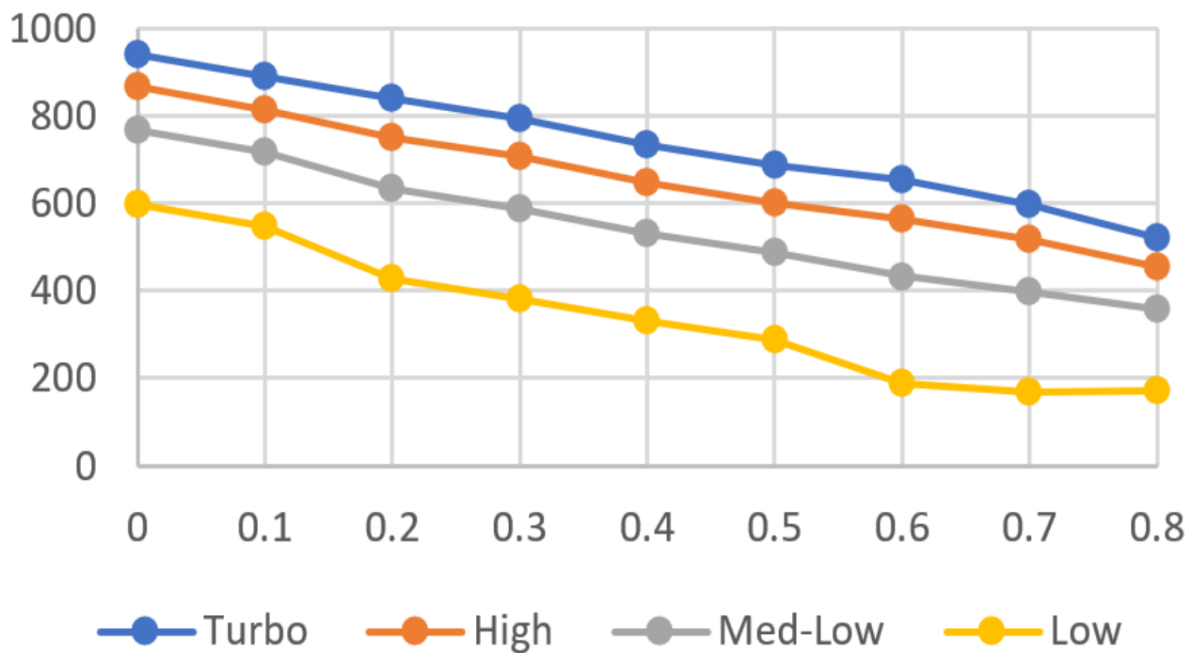

Features

- High efficiency up to 16.8 SEER2, 12 EER2, 10.5 HSPF2
- Aluminum Coil
- IDU compatible with 115V and 230V
- Constantly Air Flow system up to 0.80 In.W.G
- Optional Auxiliary heat kit up to 10kW
- Easy Maintenance
- Multiple control options available:
 - Two way communication wired controller:120N(X6)
 - Two way communication wired controller with built-in WiFi:120N(X6W)
 - Wireless remote controller
 - Third-Party 24V Thermostat
- Adaptive Control wiring method on 24V and RS485
- Downward or Backward (optional) air inlet
- Chassis heater and crankcase heater equipped as standard