

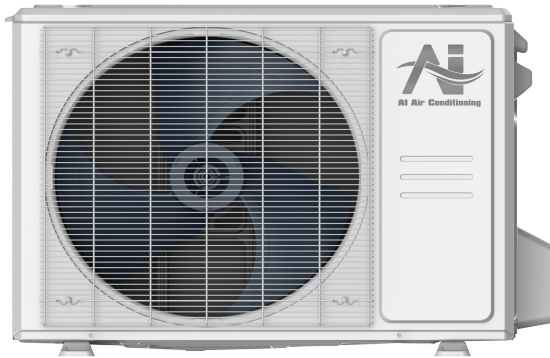

Location: _____
 Engineer: _____
 Submitted to: _____
 Submitted by: _____
 Reference: _____

Model Number: AO24-18N2-M1 / AL-18N2-M1

Approval: _____
 Date: _____
 Construction: _____
 Unit #: _____
 Drawing #: _____

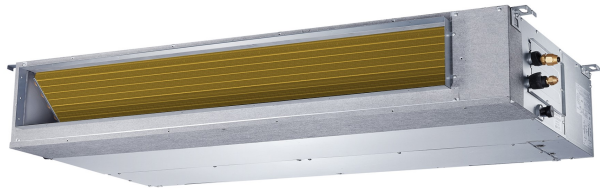

INDOOR SPECIFICATION

Indoor Air Flow (Turbo/H/M/L/S) (CFM)	600/559/500/441/441	
Indoor Noise Level (T/H/M/L/S) (dBA)	41/41/39/38/35	
Indoor static pressure range	0-0.4	
Dimension (W×D×H)	inch	34-5/8 x 26-1/2 x 8-1/4
	mm	880 x 674 x 210
Package (W×D×H)	inch	42-1/8 x 28-1/2 x 11
	mm	1070 x 725 x 280
Net/Gross Weight	lbs	54/66
	kg	24.7/30

OUTDOOR SPECIFICATION

Compressor Type	ROTARY	
Refrigerant	R454B	
Factory Charge	440ml	
Refrigerant Oil	VG74	
Outdoor Air Flow (Max) (CFM)	1765.8	
Outdoor Noise Level (dBA)	59.0	
Dimension (W×D×H)	inch	35 x 13-1/2 x 26-1/2
	mm	890 x 342 x 673
Package (W×D×H)	inch	39-1/8 x 15-5/8 x 29-1/8
	mm	995 x 398 x 740
Net/Gross Weight	lbs	93/100
	kg	42.0/45.5

EFFICIENCY

Cooling		Heating	
SEER2	20.0	HSPF2-4	10.5
EER2	12.5	COP	3.5

PERFORMANCE of Cooling

Cooling (Btu/hr)

Rated Capacity	17000
Min/Max Capacity	7000~19000
Moisture Removal	1.5
Standard Operating Range	-13°F~122°F (-25°C~50°C)

Rated Cooling Conditions: Indoor: 80°F DB/67°F WB
 Outdoor: 95°F DB/75°F WB

PERFORMANCE of Heating

Heating (Btu/hr)

1. @ 47°F Rated (Min/Max)	20000(5500~22000)
2. @ 17°F Rated	14000
3. @ 5°F Max: Capacity / COP	14200/2.20
Standard Operating Range	-13°F~75°F (-25°C~24°C)

1. Rated Heating Conditions: Indoor: 70°F DB/60°F WB
 Outdoor: 47°F DB/43°F WB

2. Rated Heating Conditions: Indoor: 70°F DB/60°F WB
 Outdoor: 17°F DB/15°F WB

3. Heating Conditions, Compressor Operating at Max. Frequency: Indoor: 70°F DB/60°F WB
 Outdoor: 5°F DB/5°F WB

ELECTRICAL

Power Supply	208/230V, 60Hz, 1Ph
System MCA	18
Connection Wiring	AWG 14-4
System MOCP	20
Compressor RLA	10.0
Outdoor Fan Motor RLA	0.9
Outdoor Fan Motor W	80
Indoor Fan Motor RLA	1.2
Indoor Fan Motor W	165
System Power Input @ Cooling (W)	1445(600 ~ 1750)
System Power Input @ Heating (W)	1690(330 ~ 1850)
MCA: Min. circuit amps (A)	MOCP: Max. over current protection (A)
RLA: Rated load amps (A)	W: Fan motor rated output (W)

PIPING

Liquid Size	1/4in (6.35mm)
Gas Size	1/2in (12.7mm)
Drain Size	5/8in (15.88mm)
Max. Piping Length	98.4ft (30m)
Max. Height Difference	65.6ft (20m)
Max. Pre-charged Length	24.6ft (7.5m)
Refrigerant Pre-charged Amount	47.97oz (1360g)
Additional Charge of Refrigerant	0.16oz/ft (15g/m)
Connection Method	Flared

Indoor Unit Dimension

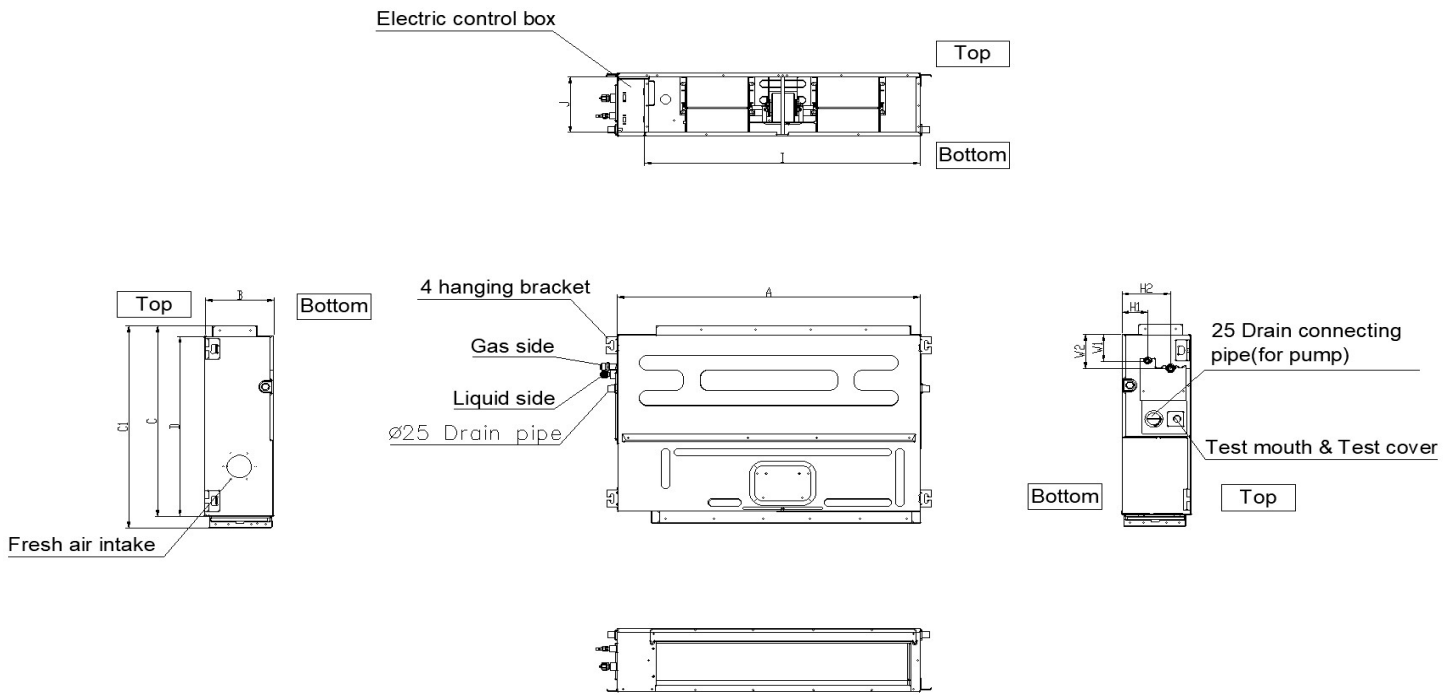

Model(kBtu/h)	unit	A	B	C	C1	D
	6 -12	mm	700	200	470	506
in		27-1/2	7-7/8	18-1/2	20	17-3/4
18	mm	880	210	634	674	600
	in	34-5/8	8-1/4	25	26-1/2	23-5/8

Installation Instruction

Installation place

The distance between the mounted indoor unit should meet the specifications illustrated in the following diagram.

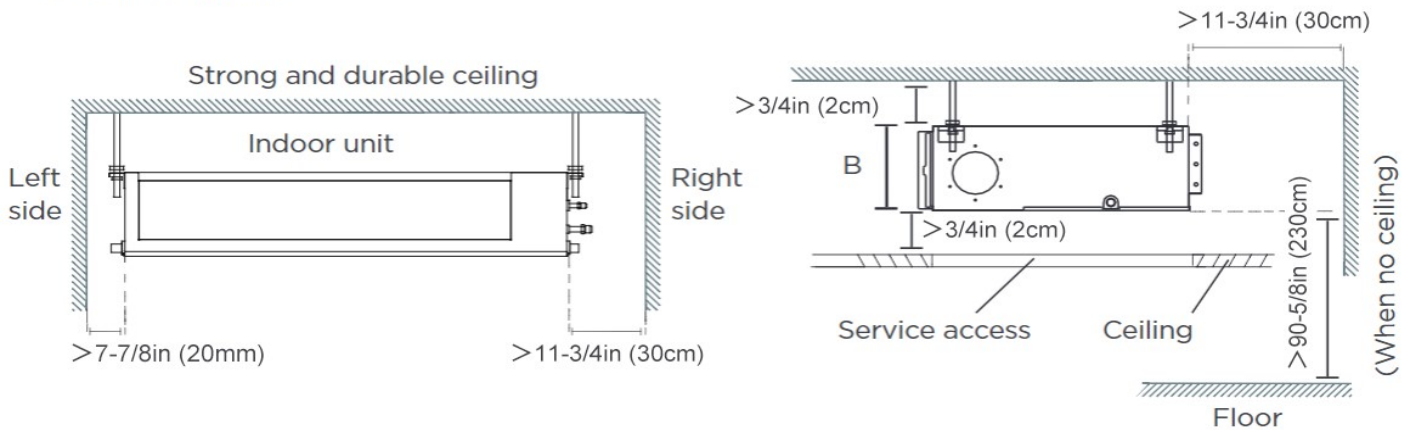

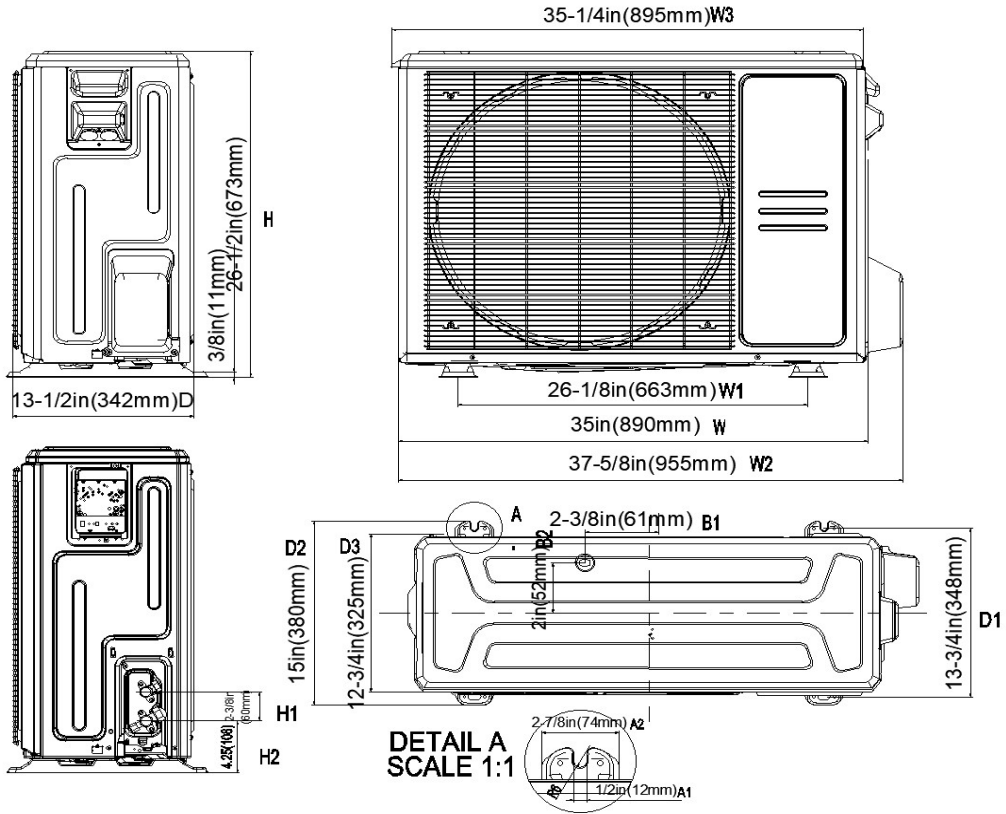

Installation Instruction

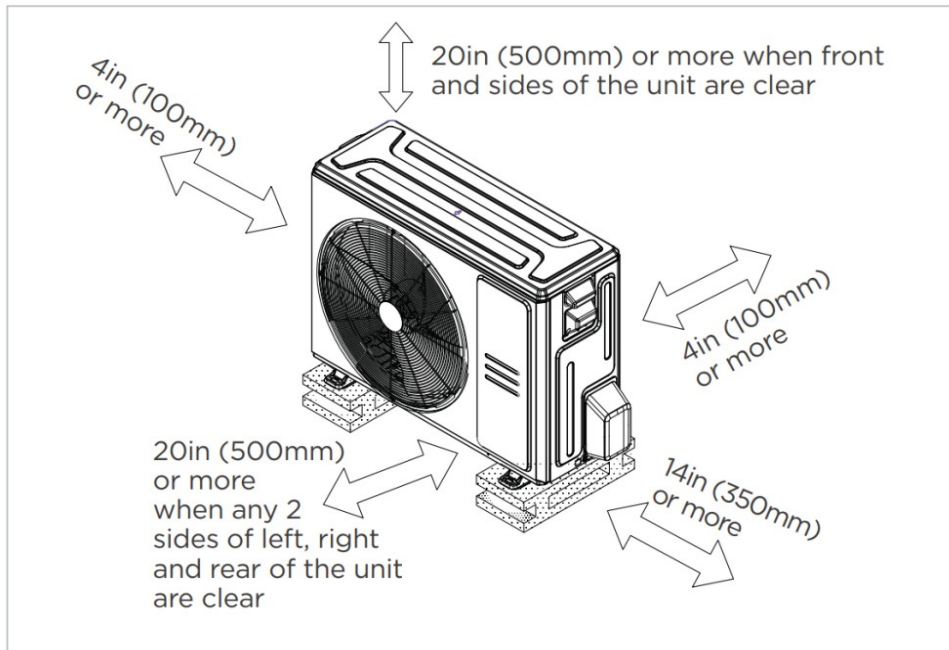

Meets all special requirements shown in Installation Clearance Requirements above.

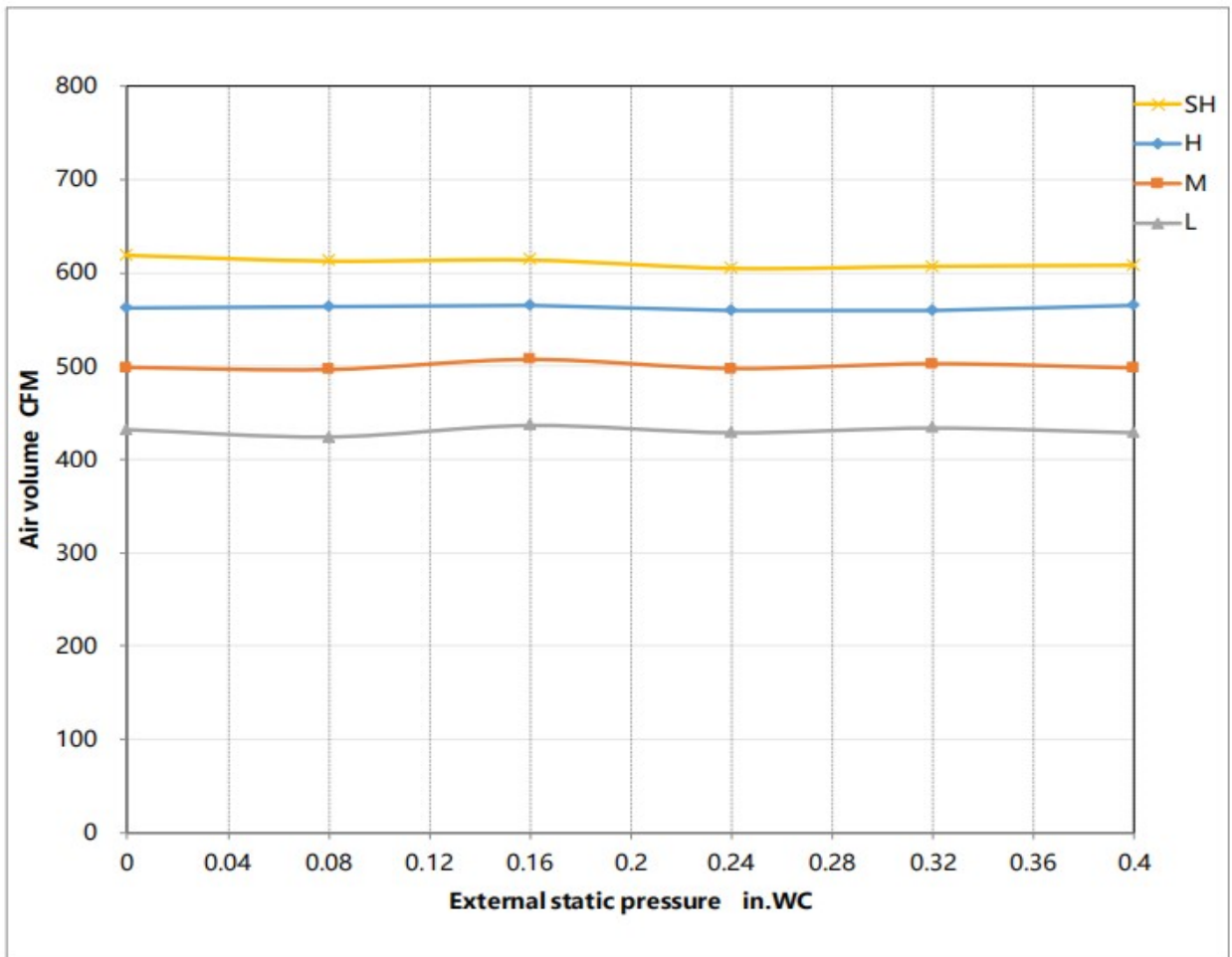
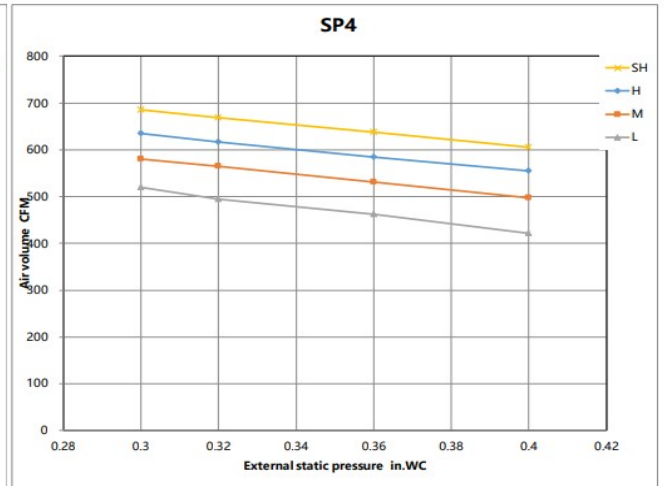
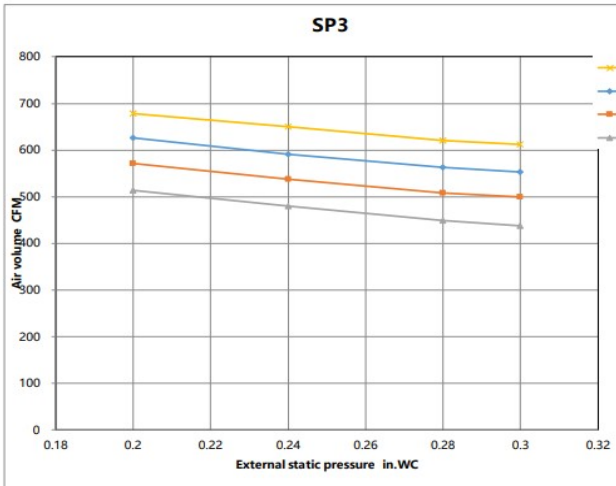
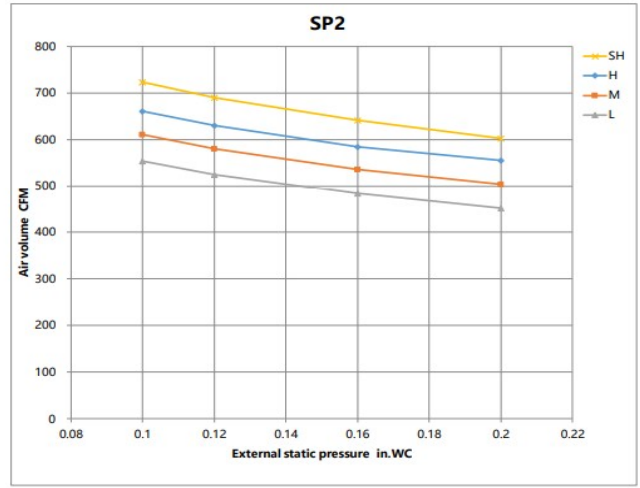
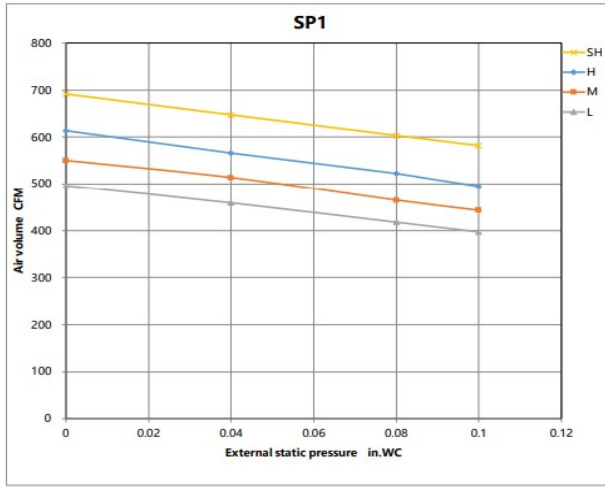

Features

- Static pressure with 4 levels to select
- Refrigerant leakage detector
- Constant airflow
- Built-in water pump
- i-clean function (AI self cleaning)
- 1~100% stepless adjustable fan speed setting
- WiFi capability: through WiFi module or wired controller with WiFi function
- OTA function: can upgrade the program version via wired controller 120N(X6W)
- 2-pin connector(HA/HB) for programmable wired controller
- Multiple controller options available:
 - Optional two way communication wired controller, programmable:120N(X6)
 - Optional two way communication wired controller, programmable, with built-in WiFi, :120N(X6W)
 - Optional Infrared wired controller: 120L
 - Optional Wireless remote controller
 - Optional 24V interface kit, can connect with Third-Party 24V Thermostat