

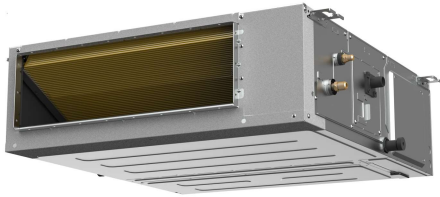

Location: _____
 Engineer: _____
 Submitted to: _____
 Submitted by: _____
 Reference: _____

Model Number: ASO24-48N2-M2 / AH-48N2-M1

Approval: _____
 Date: _____
 Construction: _____
 Unit #: _____
 Drawing #: _____



INDOOR SPECIFICATION		
Indoor Air Flow (Turbo/H/M/L/S) (CFM)	1648/1472/1295/1060/1060	
Indoor Noise Level (T/H/M/L/S) (dBA)	51/51/46/42/40	
Indoor static pressure range	0-0.8	
Dimension (W×D×H)	inch	47-1/4 x 29-1/2 x 11-3/4
	mm	1200 x 750 x 300
Package (W×D×H)	inch	56-1/8 x 33-7/8 x 14-1/8
	mm	1425 x 860 x 359
Net/Gross Weight	lbs	111/125
	kg	50.5/56.6

OUTDOOR SPECIFICATION		
Compressor Type	ROTARY	
Refrigerant	R454B	
Factory Charge	1400ml	
Refrigerant Oil	VG74	
Outdoor Air Flow (Max) (CFM)	4237.9	
Outdoor Noise Level (dBA)	64.0	
Dimension (W×D×H)	inch	37-1/2 x 16-3/8 x 52-1/2
	mm	952 x 415 x 1333
Package (W×D×H)	inch	43-1/8 x 19-1/2 x 57-1/2
	mm	1095 x 495 x 1460
Net/Gross Weight	lbs	209/240
	kg	94.7/108.8

EFFICIENCY			
Cooling		Heating	
SEER2	17.1	HSPF2-4	9.8
EER2	10.0	COP	3.5

PERFORMANCE of Cooling	
Cooling (Btu/hr)	
Rated Capacity	48000
Min/Max Capacity	11000~56500
Moisture Removal	4.0
Standard Operating Range	-13°F~122°F (-25°C~50°C)
Rated Cooling Conditions:	Indoor: 80°F DB/67°F WB Outdoor: 95°F DB/75°F WB

PERFORMANCE of Heating	
Heating (Btu/hr)	
1. @ 47°F Rated (Min/Max)	50000(11200~60500)
2. @ 17°F Rated	39000
3. @ 5°F Max: Capacity / COP	38000/2.00
Standard Operating Range	-13°F~75°F (-25°C~24°C)
1. Rated Heating Conditions:	Indoor: 70°F DB/60°F WB Outdoor: 47°F DB/43°F WB
2. Rated Heating Conditions:	Indoor: 70°F DB/60°F WB Outdoor: 17°F DB/15°F WB
3. Heating Conditions, Compressor Operating at Max. Frequency	Indoor: 70°F DB/60°F WB Outdoor: 5°F DB/5°F WB

ELECTRICAL	
Power Supply	208/230V,60Hz,1Ph
System MCA	39
Connection Wiring	AWG 14-3
System MOCP	40
Compressor RLA	24.0
Outdoor Fan Motor RLA	1.2
Outdoor Fan Motor W	85
Indoor Fan Motor RLA	4.0
Indoor Fan Motor W	560
System Power Input @ Cooling (W)	4800(930 ~ 5850)
System Power Input @ Heating (W)	4200(780 ~5100)
MCA: Min. circuit amps (A)	MOCP: Max. over current protection (A)
RLA: Rated load amps (A)	W: Fan motor rated output (W)

PIPING	
Liquid Size	3/8in (9.52mm)
Gas Size	3/4in (19mm)
Drain Size	5/8in (15.88mm)
Max. Piping Length	246ft (75m)
Max. Height Difference	98.4ft (30m)
Max. Pre-charged Length	24.6ft (7.5m)
Refrigerant Pre-charged Amount	126.99oz (3600g)
Additional Charge of Refrigerant	0.32oz/ft (30g/m)
Connection Method	Flared

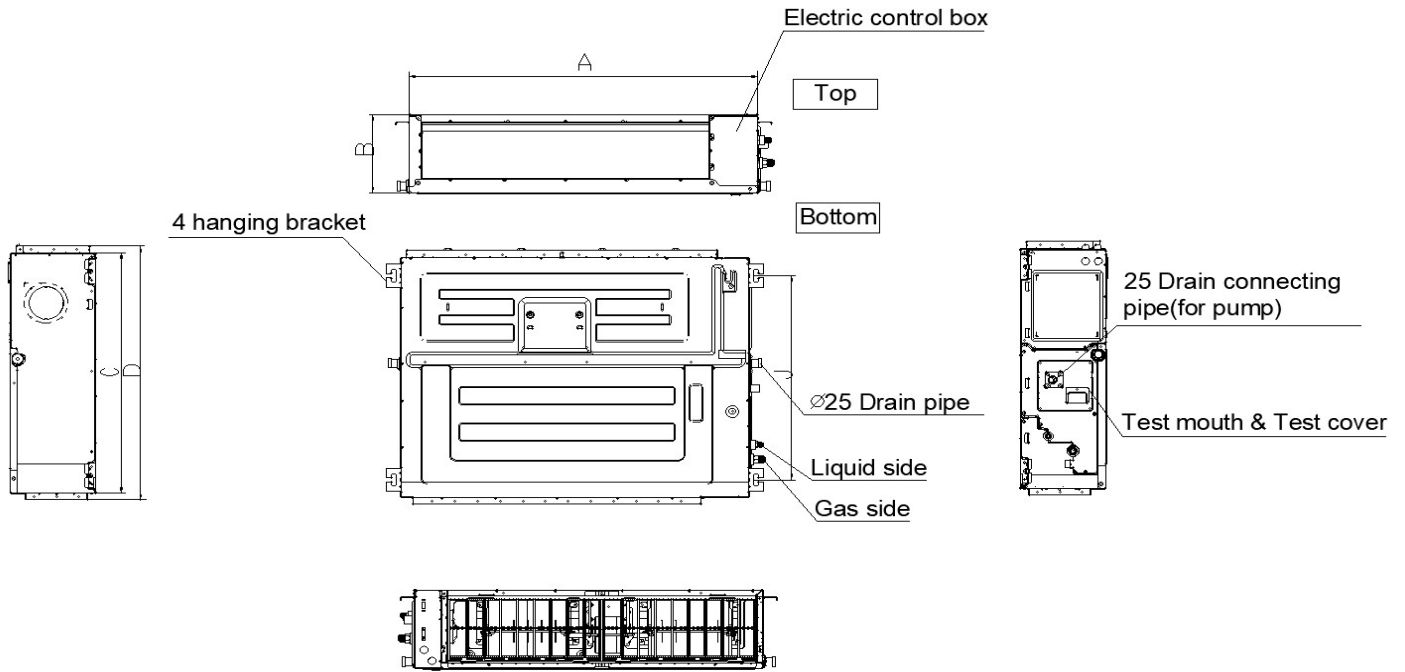

MODEL	A	B	C	D
9K	27-1/2in(700mm)	7-7/8in(200mm)	17-3/4(450mm)	20in(506mm)
12K	27-1/2in(700mm)	9-5/8in(245mm)	29-1/2(750mm)	31-1/4in(795mm)
18K~24K	39-3/8in(1000mm)	9-5/8in(245mm)	29-1/2(750mm)	31-1/4in(795mm)
36K~48K	47-1/8in(1200mm)	11-7/8in(300mm)	29-1/2(750mm)	31-1/4in(795mm)
60K	55-1/8in(1400mm)	15in(380mm)	31-1/2in(800mm)	33-1/4in(845mm)

Installation place

The distance between the mounted indoor unit should meet the specifications illustrated in the following diagram.

1) Ceiling-mounted

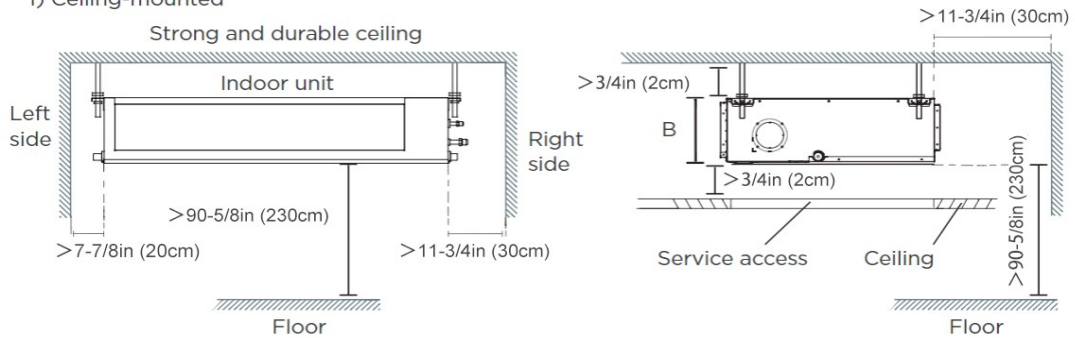

2) Wall-mounted

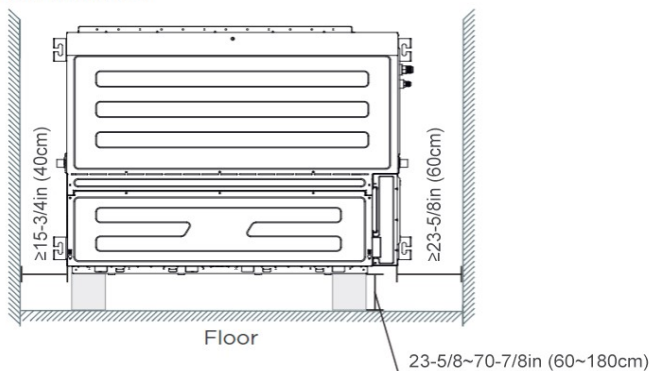

Outdoor Unit Dimension

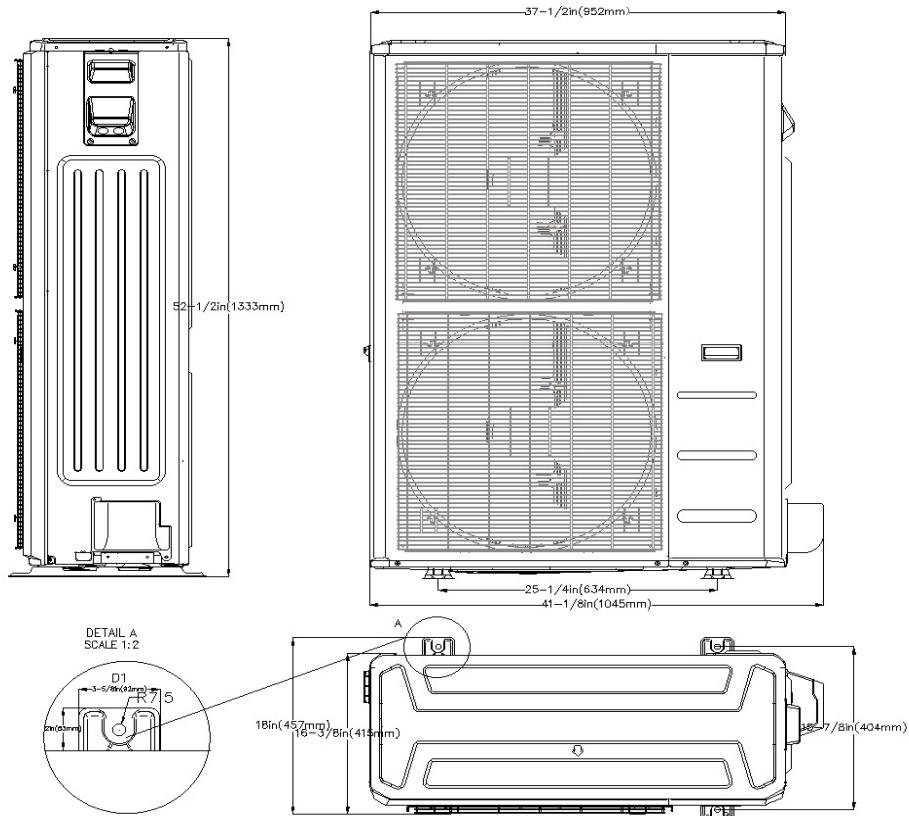

Installation Instruction

REQUIRED CLEARANCE

*1 20in. (500mm) or more when front and sides of the unit are clear

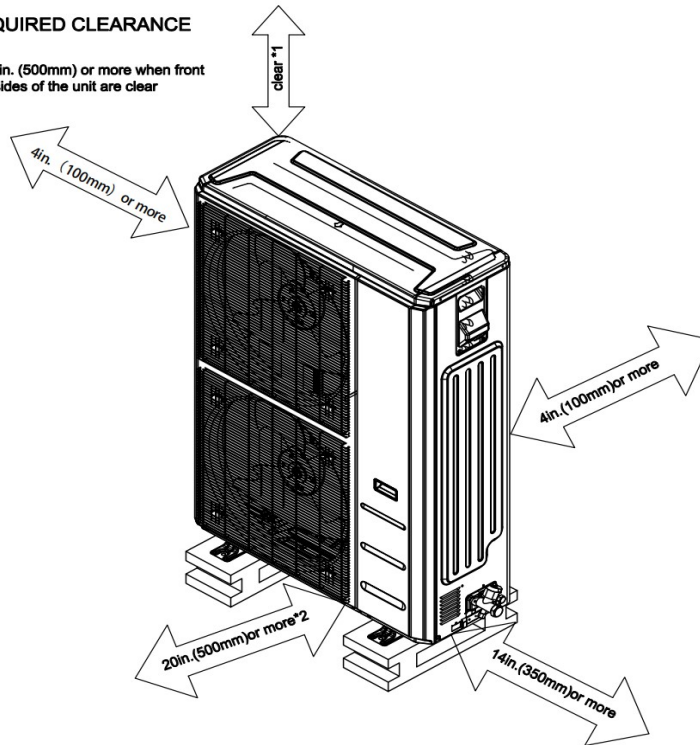

*2 When any 2 sides of left, right and rear of the unit are clear

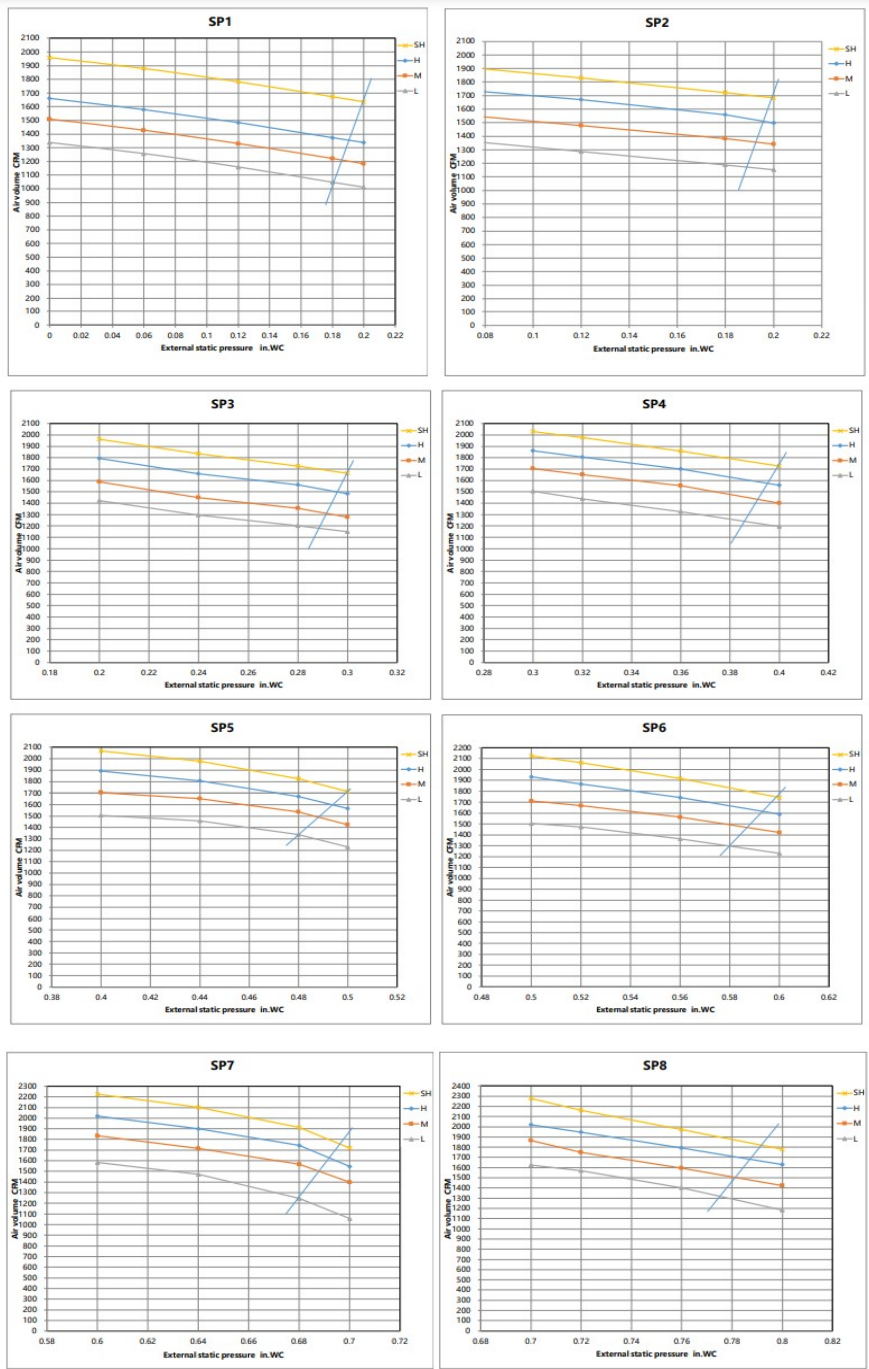

Constant air volume

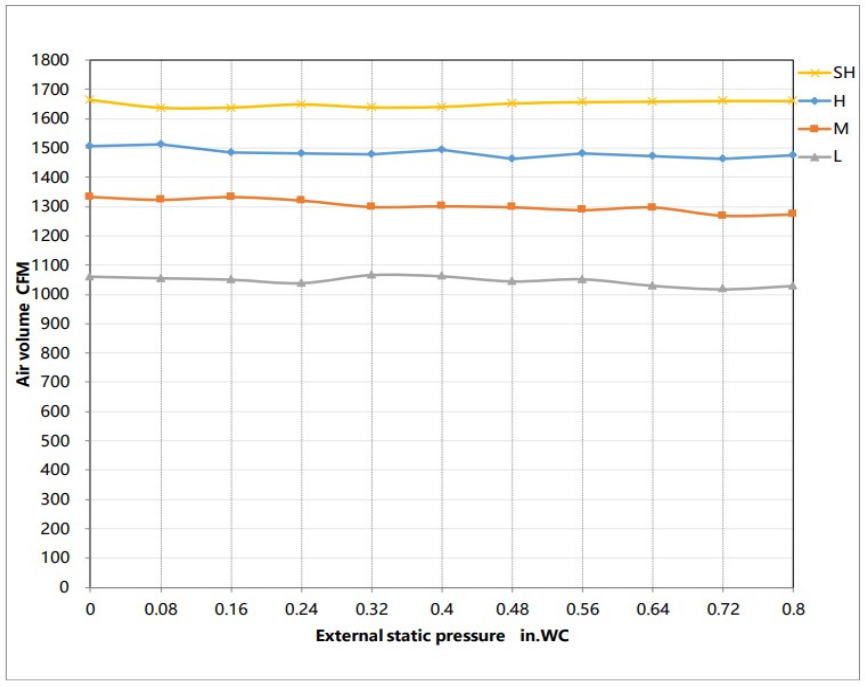

Features

- Compatible with both horizontal and vertical installation
- Static pressure up to 0.8 in.w.g(for all models)
- Static pressure with 8 levels to select
- Refrigerant leakage detector
- Constant airflow
- Built-in water pump
- i-clean function (AI self cleaning)
- 1~100% stepless adjustable fan speed setting
- WiFi capability: through WiFi module or wired controller with WiFi function
- OTA function: can upgrade the program version via wired controller 120N(X6W)
- 2-pin connector(HA/HB) for programmable wired controller
- Multiple controller options available:
 - Optional two way communication wired controller, programmable:120N(X6)
 - Optional two way communication wired controller, programmable, with built-in WiFi, :120N(X6W)
 - Optional Infrared wired controller: 120L
 - Optional Wireless remote controller
 - Optional 24V interface kit, can connect with Third-Party 24V Thermostat