

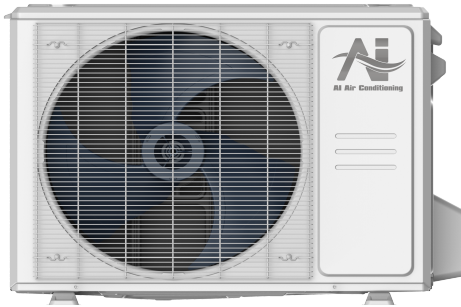

Location: _____
 Engineer: _____
 Submitted to: _____
 Submitted by: _____
 Reference: _____

Model Number: AO24-18N2-M1 / AH-18N2-M1

Approval: _____
 Date: _____
 Construction: _____
 Unit #: _____
 Drawing #: _____

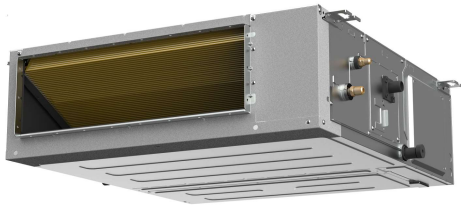

INDOOR SPECIFICATION

Indoor Air Flow (Turbo/H/M/L/S) (CFM)	706/618/530/441/441	
Indoor Noise Level (T/H/M/L/S) (dBA)	40/37/35/33/29	
Indoor static pressure range	0-0.8	
Dimension (W×D×H)	inch	39-3/8 x 29-1/2 x 9-5/8
	mm	1000 x 750 x 245
Package (W×D×H)	inch	48-1/4 x 33-7/8 x 12
	mm	1225 x 860 x 304
Net/Gross Weight	lbs	80/91
	kg	36.2/41.4

OUTDOOR SPECIFICATION

Compressor Type	ROTARY	
Refrigerant	R454B	
Factory Charge	440ml	
Refrigerant Oil	VG74	
Outdoor Air Flow (Max) (CFM)	1765.8	
Outdoor Noise Level (dBA)	58.0	
Dimension (W×D×H)	inch	35 x 13-1/2 x 26-1/2
	mm	890 x 342 x 673
Package (W×D×H)	inch	39-1/8 x 15-5/8 x 29-1/8
	mm	995 x 398 x 740
Net/Gross Weight	lbs	93/100
	kg	42.0/45.5

EFFICIENCY

Cooling		Heating	
SEER2	20.0	HSPF2-4	11.3
EER2	13.3	COP	3.9

PERFORMANCE of Cooling

Cooling (Btu/hr)	
Rated Capacity	17500
Min/Max Capacity	4500~20200
Moisture Removal	1.7
Standard Operating Range	-13°F~122°F (-25°C~50°C)
Rated Cooling Conditions:	Indoor: 80°F DB/67°F WB Outdoor: 95°F DB/75°F WB

PERFORMANCE of Heating

Heating (Btu/hr)	
1. @ 47°F Rated (Min/Max)	20000(5200~23000)
2. @ 17°F Rated	14900
3. @ 5°F Max: Capacity / COP	14200/2.40
Standard Operating Range	-13°F~75°F (-25°C~24°C)
1. Rated Heating Conditions:	Indoor: 70°F DB/60°F WB Outdoor: 47°F DB/43°F WB
2. Rated Heating Conditions:	Indoor: 70°F DB/60°F WB Outdoor: 17°F DB/15°F WB
3. Heating Conditions, Compressor Operating at Max. Frequency	Indoor: 70°F DB/60°F WB Outdoor: 5°F DB/5°F WB

ELECTRICAL

Power Supply	208/230V, 60Hz, 1Ph
System MCA	18
Connection Wiring	AWG 14-4
System MOCP	20
Compressor RLA	10.0
Outdoor Fan Motor RLA	0.9
Outdoor Fan Motor W	80
Indoor Fan Motor RLA	1.8
Indoor Fan Motor W	165
System Power Input @ Cooling (W)	1315(570 ~ 1770)
System Power Input @ Heating (W)	1500(310 ~1720)
MCA: Min. circuit amps (A)	MOCP: Max. over current protection (A)
RLA: Rated load amps (A)	W: Fan motor rated output (W)

PIPING

Liquid Size	1/4in (6.35mm)
Gas Size	1/2in (12.7mm)
Drain Size	5/8in (15.88mm)
Max. Piping Length	98.4ft (30m)
Max. Height Difference	65.6ft (20m)
Max. Pre-charged Length	24.6ft (7.5m)
Refrigerant Pre-charged Amount	47.97oz (1360g)
Additional Charge of Refrigerant	0.16oz/ft (15g/m)
Connection Method	Flared

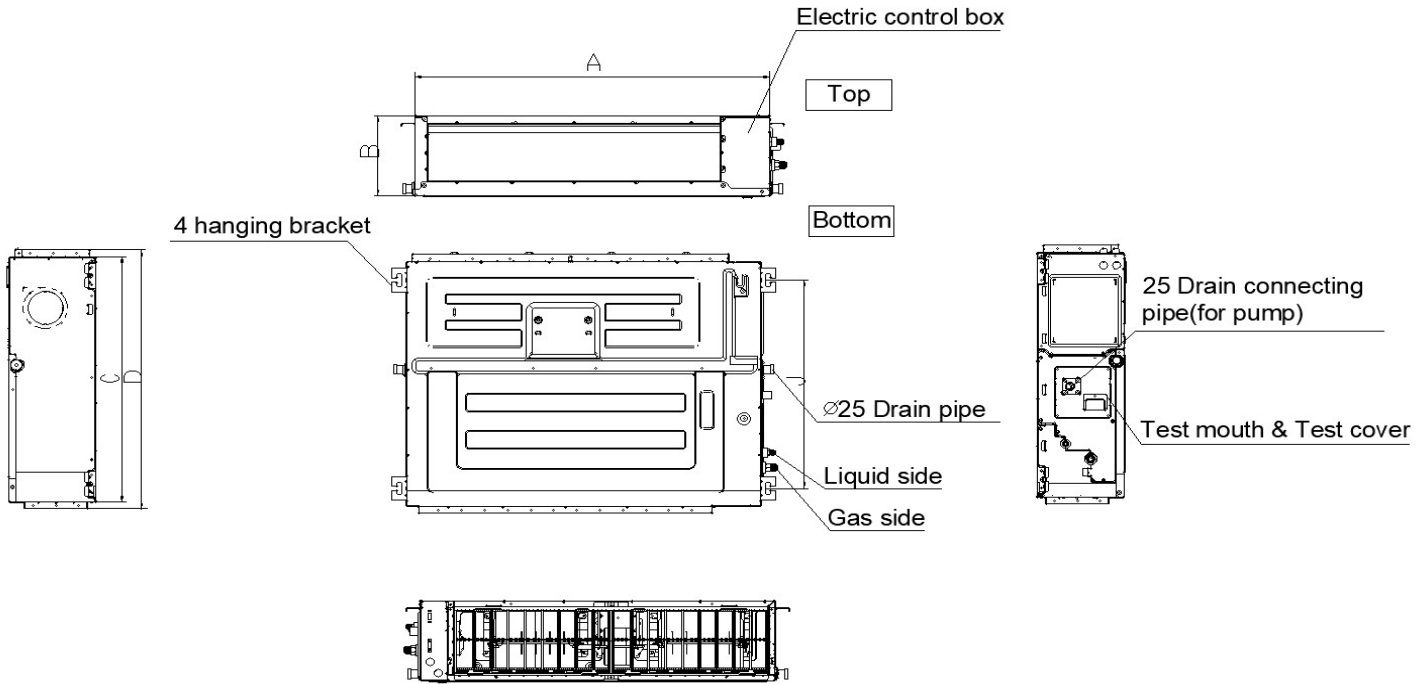

MODEL	A	B	C	D
9K	27-1/2in(700mm)	7-7/8in(200mm)	17-3/4(450mm)	20in(506mm)
12K	27-1/2in(700mm)	9-5/8in(245mm)	29-1/2(750mm)	31-1/4in(795mm)
18K~24K	39-3/8in(1000mm)	9-5/8in(245mm)	29-1/2(750mm)	31-1/4in(795mm)
36K~48K	47-1/8in(1200mm)	11-7/8in(300mm)	29-1/2(750mm)	31-1/4in(795mm)
60K	55-1/8in(1400mm)	15in(380mm)	31-1/2in(800mm)	33-1/4in(845mm)

Installation place

The distance between the mounted indoor unit should meet the specifications illustrated in the following diagram.

1) Ceiling-mounted

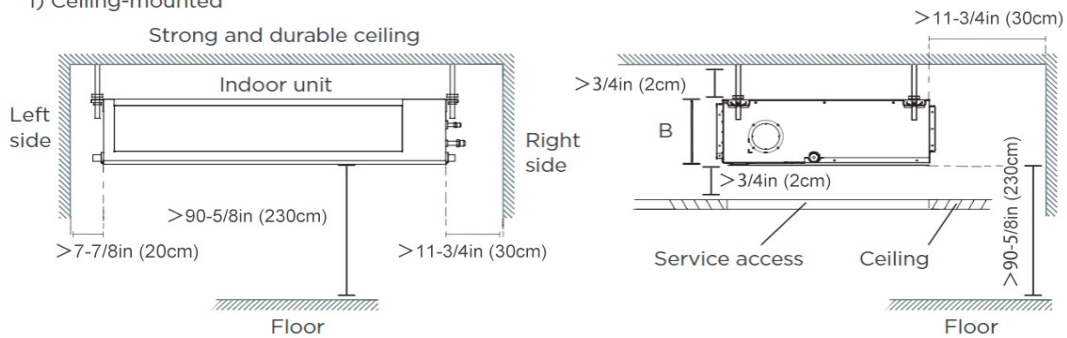

2) Wall-mounted

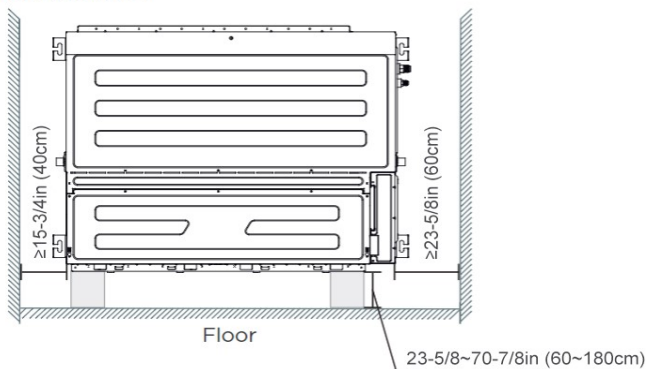

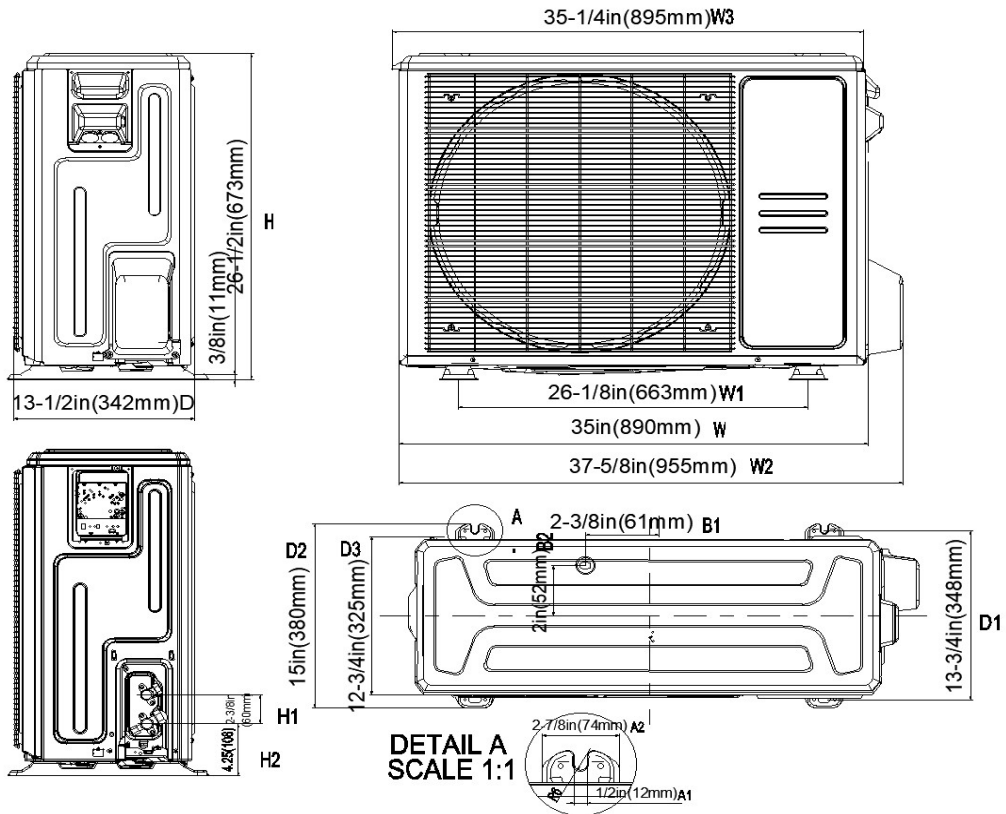

Installation Instruction

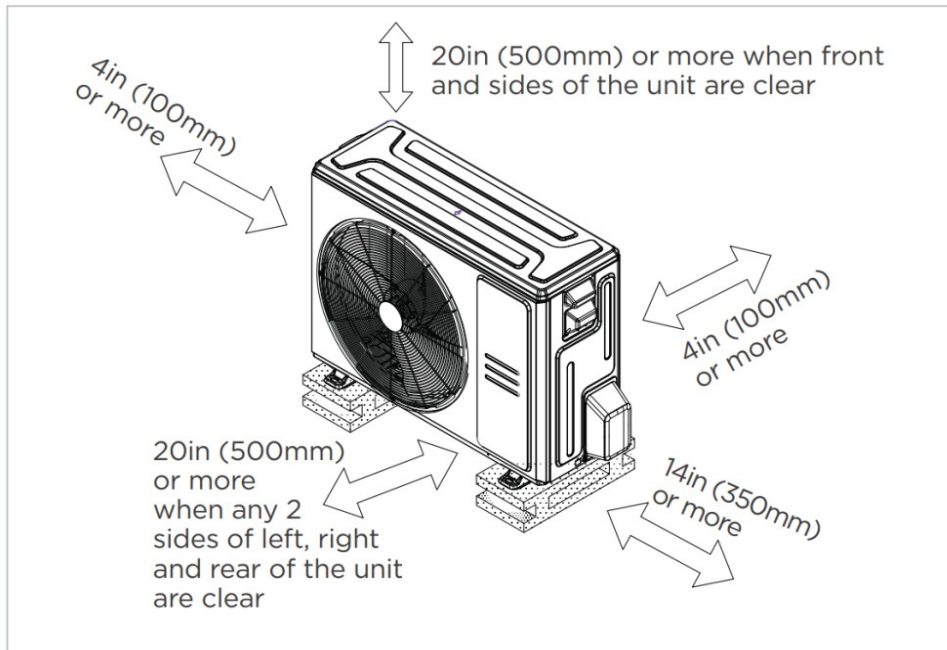

Meets all special requirements shown in Installation Clearance Requirements above.

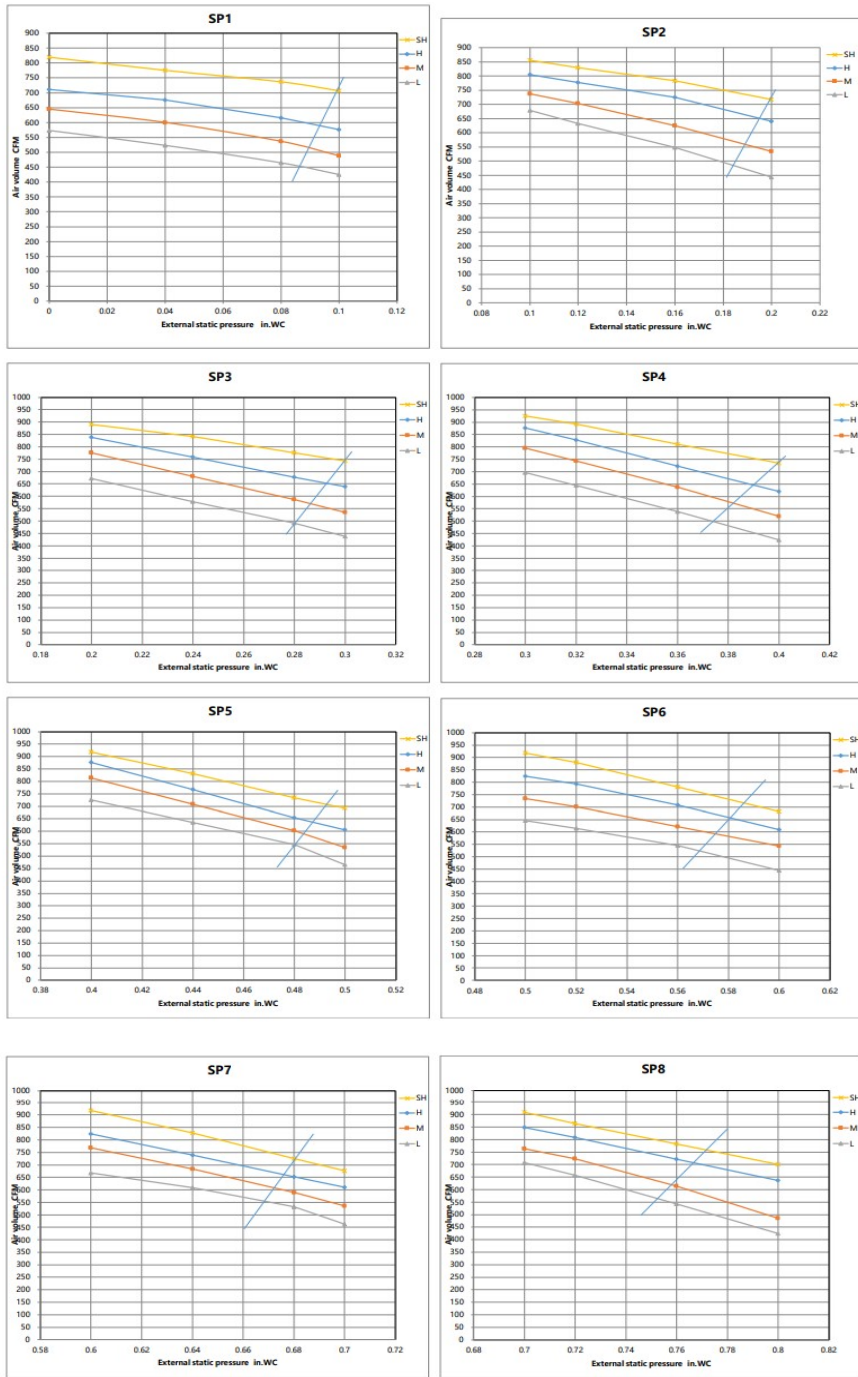

Constant air volume

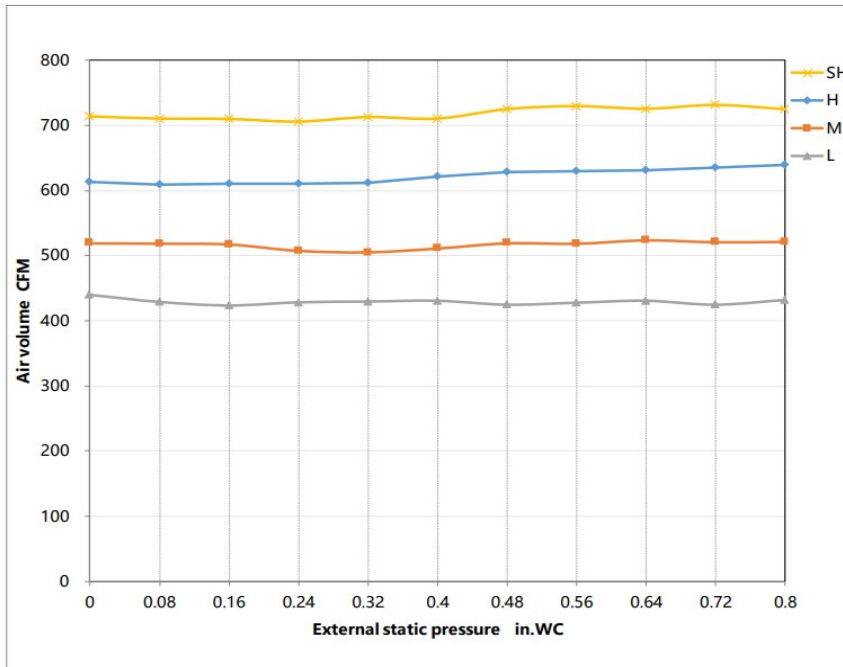

Features

- Compatible with both horizontal and vertical installation
- Static pressure up to 0.8 in.w.g(for all models)
- Static pressure with 8 levels to select
- Refrigerant leakage detector
- Constant airflow
- Built-in water pump
- i-clean function (AI self cleaning)
- 1~100% stepless adjustable fan speed setting
- WiFi capability: through WiFi module or wired controller with WiFi function
- OTA function: can upgrade the program version via wired controller 120N(X6W)
- 2-pin connector(HA/HB) for programmable wired controller
- Multiple controller options available:
 - Optional two way communication wired controller, programmable:120N(X6)
 - Optional two way communication wired controller, programmable, with built-in WiFi, :120N(X6W)
 - Optional Infrared wired controller: 120L
 - Optional Wireless remote controller
 - Optional 24V interface kit, can connect with Third-Party 24V Thermostat