



Model Number: ASO25-48N2-M2H / AAH-48N2-DM2

Location: \_\_\_\_\_  
 Engineer: \_\_\_\_\_  
 Submitted to: \_\_\_\_\_  
 Submitted by: \_\_\_\_\_  
 Reference: \_\_\_\_\_

Approval: \_\_\_\_\_  
 Date: \_\_\_\_\_  
 Construction: \_\_\_\_\_  
 Unit #: \_\_\_\_\_  
 Drawing #: \_\_\_\_\_



INDOOR SPECIFICATION		
Indoor Air Flow (Turbo/H/M/L/S) (CFM)	1601/1472/1283/1095/1095	
Indoor Noise Level (T/H/M/L/S) (dBA)	57/55/51/48/48	
Dimension (W×D×H)	inch	24-1/2 x 21 x 53
	mm	622 x 534 x 1346
Package (W×D×H)	inch	28 x 26-3/4 x 56-1/2
	mm	710 x 680 x 1435
Net/Gross Weight	lbs	162/192
	kg	73.4/86.9

OUTDOOR SPECIFICATION		
Compressor Type	TWIN-ROTARY	
Refrigerant	R454B	
Factory Charge	1460ml	
Refrigerant Oil	VG75	
Outdoor Air Flow (Max) (CFM)	4237.9	
Outdoor Noise Level (dBA)	65.0	
Dimension (W×D×H)	inch	37-1/2 x 16-3/8 x 52-1/2
	mm	952 x 415 x 1333
Package (W×D×H)	inch	43-1/8 x 19-1/2 x 57-1/2
	mm	1095 x 495 x 1460
Net/Gross Weight	lbs	209/240
	kg	94.7/108.8

EFFICIENCY			
Cooling		Heating	
SEER2	17.0	HSPF2-4	10.2
EER2	10.0	COP	3.5

PERFORMANCE of Cooling	
Cooling (Btu/hr)	
Rated Capacity	48000
Min/Max Capacity	7300~55500
Moisture Removal	4.84
Standard Operating Range	-22°F~122°F (-30°C~50°C)
Rated Cooling Conditions:	Indoor: 80°F DB/67°F WB Outdoor: 95°F DB/75°F WB

PERFORMANCE of Heating	
Heating (Btu/hr)	
1. @ 47°F Rated (Min/Max)	50000(9500~65000)
2. @ 17°F Rated	40000
3. @ 5°F Max: Capacity / COP	46000/2
Standard Operating Range	-22°F~75°F (-30°C~24°C)
1. Rated Heating Conditions:	Indoor: 70°F DB/60°F WB Outdoor: 47°F DB/43°F WB
2. Rated Heating Conditions:	Indoor: 70°F DB/60°F WB Outdoor: 17°F DB/15°F WB
3. Heating Conditions, Compressor Operating at Max. Frequency	Indoor: 70°F DB/60°F WB Outdoor: 5°F DB/5°F WB

ELECTRICAL	
Power Supply	208/230V, 60Hz, 1Ph
System MCA	44
Connection Wiring	AWG 14-3
System MOCP	45
Compressor RLA	27
Outdoor Fan Motor RLA	1.2
Outdoor Fan Motor W	85
Indoor Fan Motor RLA	7.8
Indoor Fan Motor W	750
System Power Input @ Cooling (W)	4752(1360 ~ 6250)
System Power Input @ Heating (W)	4186(720 ~ 5450)
MCA: Min. circuit amps (A)	MOCP: Max. over current protection (A)
RLA: Rated load amps (A)	W: Fan motor rated output (W)

PIPING	
Liquid Size	3/8in (9.52mm)
Gas Size	3/4in (19mm)
Drain Size	5/8in (15.88mm)
Max. Piping Length	246ft (75m)
Max. Height Difference	98.4ft (30m)
Max. Pre-charged Length	24.6ft (7.5m)
Refrigerant Pre-charged Amount	126.99oz (3600g)
Additional Charge of Refrigerant	0.32oz/ft (30g/m)
Connection Method	Flared

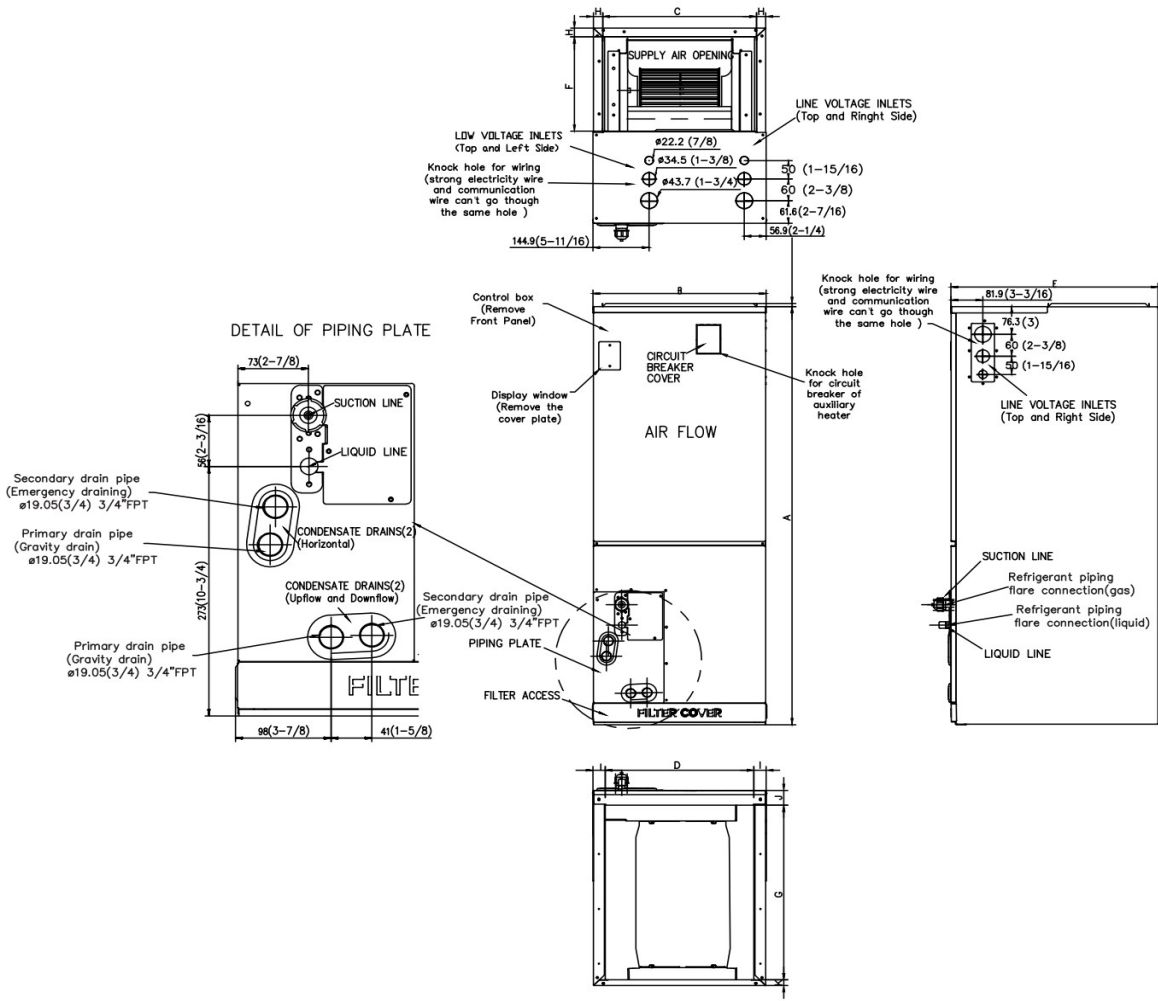

Dimensions	Model	18k/24k		30k/36k		48k/60k	
		inch	mm	inch	mm	inch	mm
A	Model Height	45	1143	49	1245	53	1346
B	Model Width	17-1/2	445	21	534	24-1/2	622
C	Supply Air Opening Width	15-5/8	397	19-1/8	486	22-5/8	575
D	Return Air Opening Width	15-1/8	384	18-5/8	473	22-1/8	562
E	Model Depth	21	534	21	534	21	534
F	Supply Air Opening Depth	10-1/4	260	10-1/4	260	10-1/4	260
G	Return Air Opening Depth	18-3/4	476	18-3/4	476	18-3/4	476
H	Supply Air Opening Clearance	15/16	24	15/16	24	15/16	24
I	Return Air Opening Side Clearance	1-1/4	32	1-1/4	32	1-1/8	28
J	Return Air Opening Front Clearance	1-1/2	38	1-5/8	41	1-5/8	41
K	Return Air Opening Back Clearance	5/8	16	5/8	16	3/4	19

Outdoor Unit Dimension

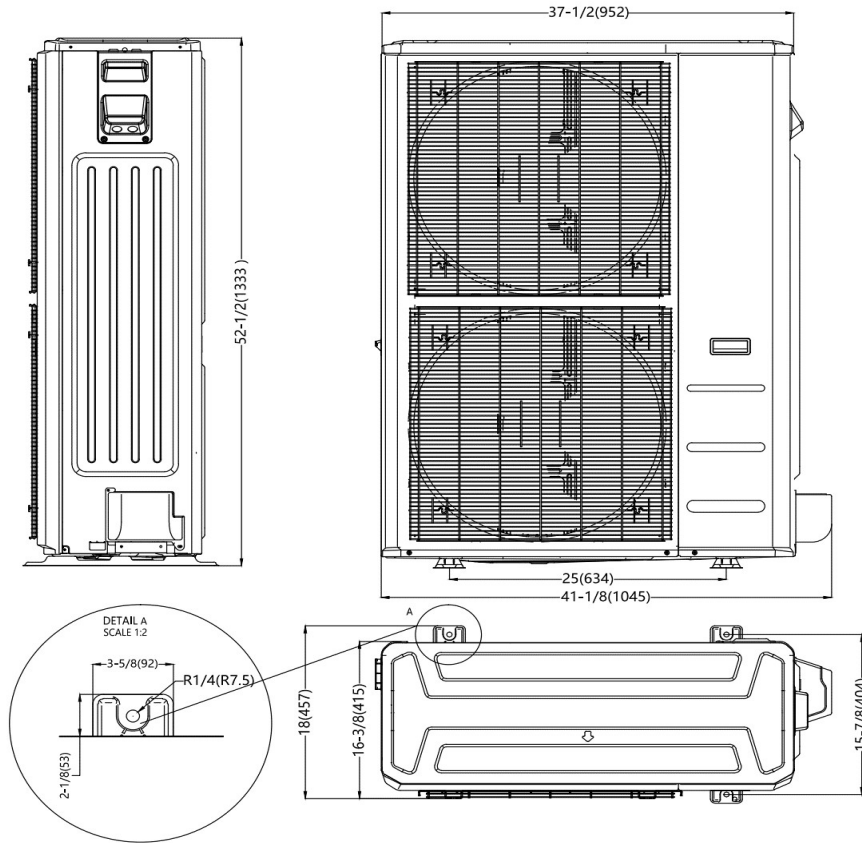

Installation Instruction

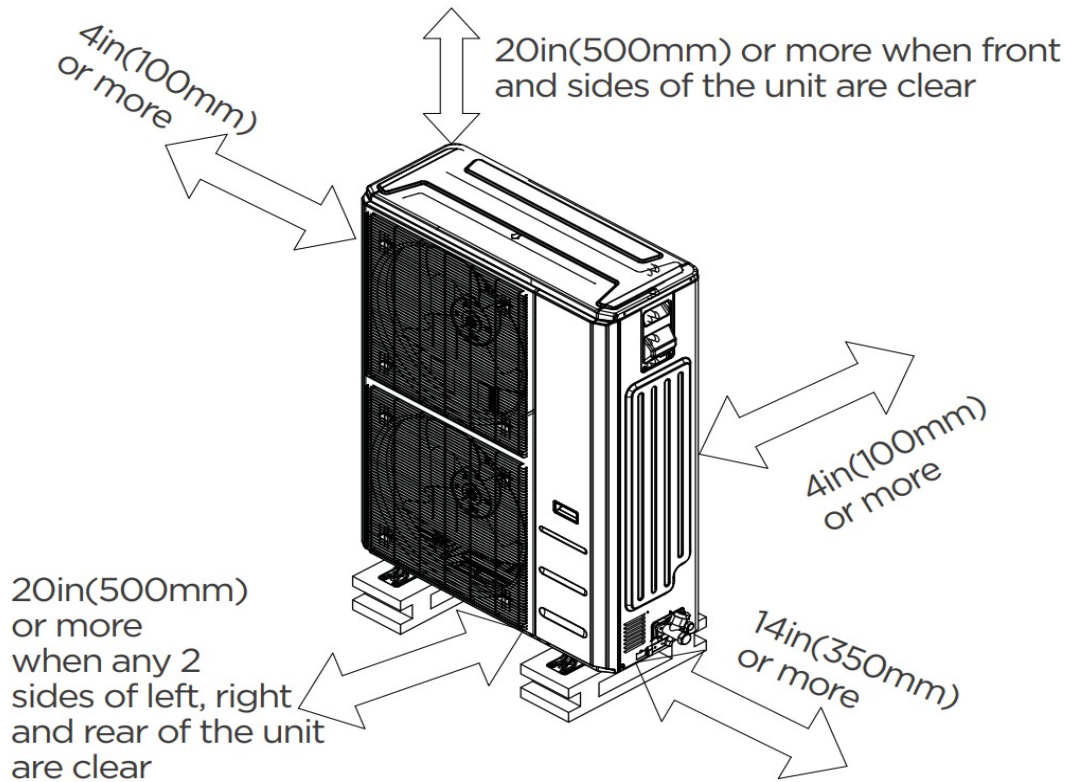

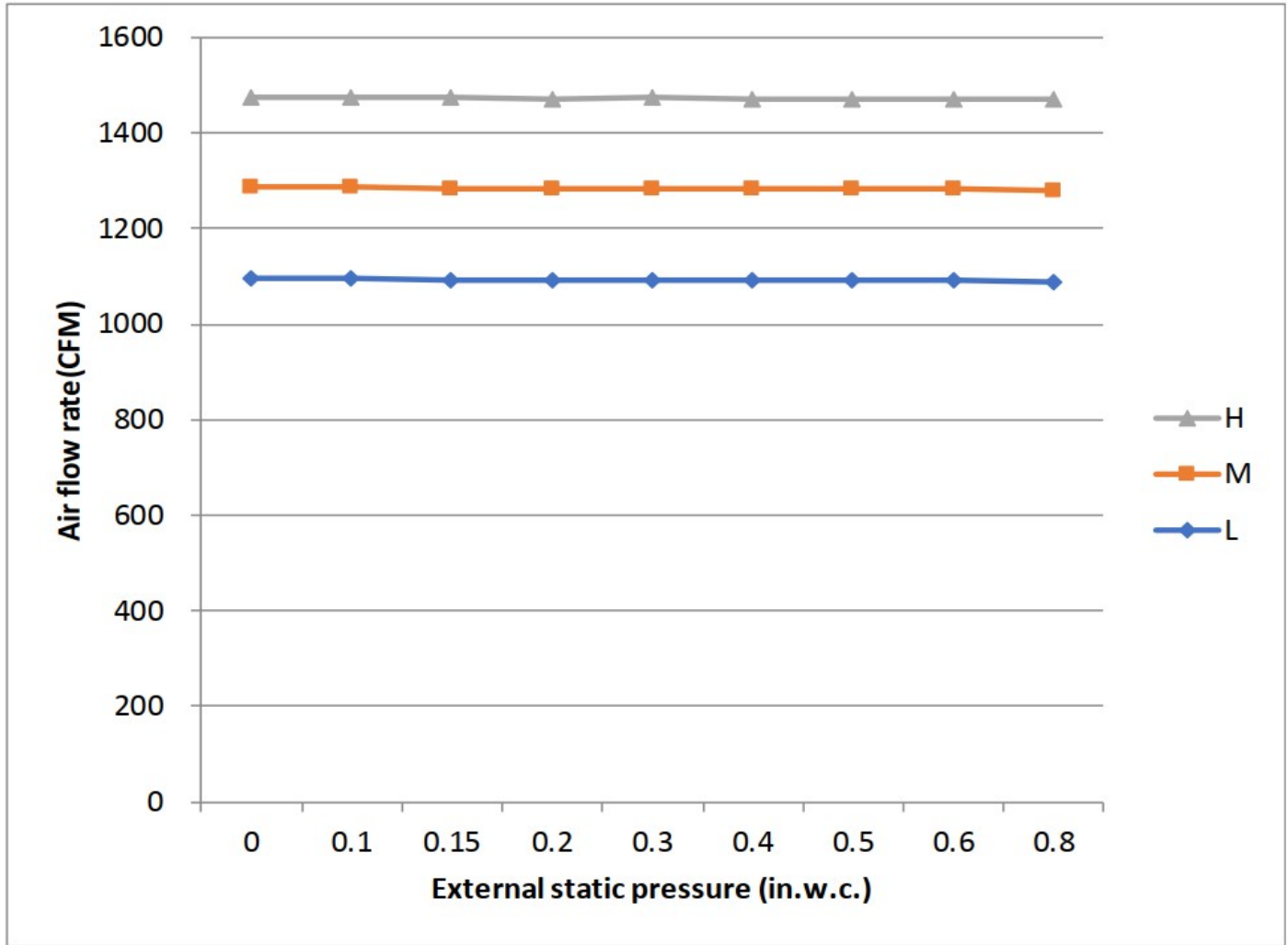

Features

- Multi-position installation: horizontal(left or right), vertical( up or down)
- Aluminum Coil
- Constantly Air Flow system up to 0.80 In.W.G
- 1 inch R4.2 fiberglass free insulation reduces condensation and boosts efficiency(optional)
- Optional Auxiliary heat kit up to 25kW
- Easy Maintenance
- Multiple control options available:
  - Two way communication wired controller:120N(X6)
  - Two way communication wired controller with built-in WiFi:120N(X6W)
  - Wireless remote controller
  - Third-Party 24V Thermostat
- Chassis heater and crankcase heater equipped as standard