

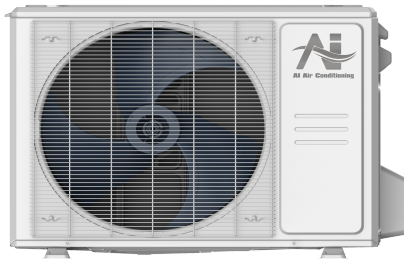

Model Number: AO25-18N2-M1H / AAH-18N2-BM1

Location: _____
 Engineer: _____
 Submitted to: _____
 Submitted by: _____
 Reference: _____

Approval: _____
 Date: _____
 Construction: _____
 Unit #: _____
 Drawing #: _____



INDOOR SPECIFICATION		
Indoor Air Flow (Turbo/H/M/L/S) (CFM)	618/577/530/489/489	
Indoor Noise Level (T/H/M/L/S) (dBA)	43/43/38/30/30	
Dimension (W×D×H)	inch	21 x 17-1/2 x 45
	mm	534 x 445 x 1143
Package (W×D×H)	inch	26-5/8 x 20-7/8 x 48-5/8
	mm	675 x 530 x 1235
Net/Gross Weight	lbs	105/126
	kg	47.5/57

OUTDOOR SPECIFICATION		
Compressor Type	ROTARY	
Refrigerant	R454B	
Factory Charge	620ml	
Refrigerant Oil	VG74	
Outdoor Air Flow (Max) (CFM)	1765.8	
Outdoor Noise Level (dBA)	59.0	
Dimension (W×D×H)	inch	35 x 13-1/2 x 26-1/2
	mm	890 x 342 x 673
Package (W×D×H)	inch	39-1/8 x 15-5/8 x 29-1/8
	mm	995 x 398 x 740
Net/Gross Weight	lbs	100/108
	kg	45.3/48.9

EFFICIENCY			
Cooling		Heating	
SEER2	18.0	HSPF2-4	10.0
EER2	12.0	COP	3.6

PERFORMANCE of Cooling	
Cooling (Btu/hr)	
Rated Capacity	18000
Min/Max Capacity	6000~20400
Moisture Removal	1.69
Standard Operating Range	-22°F~122°F (-30°C~50°C)
Rated Cooling Conditions:	Indoor: 80°F DB/67°F WB Outdoor: 95°F DB/75°F WB

PERFORMANCE of Heating	
Heating (Btu/hr)	
1. @ 47°F Rated (Min/Max)	19500(5000~21600)
2. @ 17°F Rated	14000
3. @ 5°F Max: Capacity / COP	18000/2.2
Standard Operating Range	-22°F~75°F (-30°C~24°C)
1. Rated Heating Conditions:	Indoor: 70°F DB/60°F WB Outdoor: 47°F DB/43°F WB
2. Rated Heating Conditions:	Indoor: 70°F DB/60°F WB Outdoor: 17°F DB/15°F WB
3. Heating Conditions, Compressor Operating at Max. Frequency	Indoor: 70°F DB/60°F WB Outdoor: 5°F DB/5°F WB

ELECTRICAL	
Power Supply	208/230V, 60Hz, 1Ph
System MCA	19
Connection Wiring	AWG 14-4
System MOCP	20
Compressor RLA	11.7
Outdoor Fan Motor RLA	0.9
Outdoor Fan Motor W	80
Indoor Fan Motor RLA	2.3
Indoor Fan Motor W	250
System Power Input @ Cooling (W)	1500(250 ~ 1900)
System Power Input @ Heating (W)	1570(300 ~ 1920)
MCA: Min. circuit amps (A)	MOCP: Max. over current protection (A)
RLA: Rated load amps (A)	W: Fan motor rated output (W)

PIPING	
Liquid Size	1/4in (6.35mm)
Gas Size	1/2in (12.7mm)
Drain Size	5/8in (15.88mm)
Max. Piping Length	98.4ft (30m)
Max. Height Difference	65.6ft (20m)
Max. Pre-charged Length	24.6ft (7.5m)
Refrigerant Pre-charged Amount	55.38oz (1570g)
Additional Charge of Refrigerant	0.16oz/ft (15g/m)
Connection Method	Flared

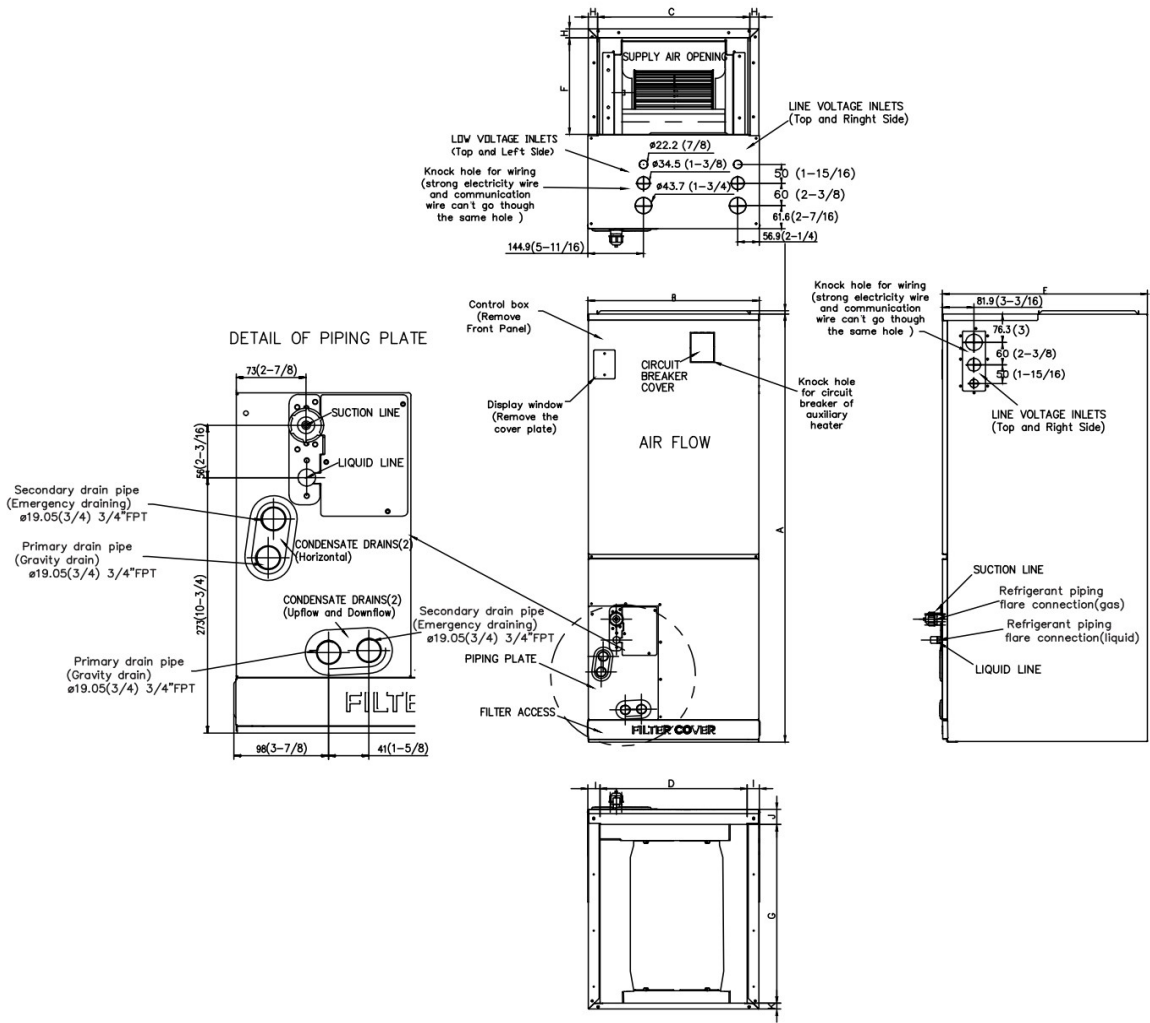

Dimensions	Model	18k/24k		30k/36k		48k/60k	
		inch	mm	inch	mm	inch	mm
A	Model Height	45	1143	49	1245	53	1346
B	Model Width	17-1/2	445	21	534	24-1/2	622
C	Supply Air Opening Width	15-5/8	397	19-1/8	486	22-5/8	575
D	Return Air Opening Width	15-1/8	384	18-5/8	473	22-1/8	562
E	Model Depth	21	534	21	534	21	534
F	Supply Air Opening Depth	10-1/4	260	10-1/4	260	10-1/4	260
G	Return Air Opening Depth	18-3/4	476	18-3/4	476	18-3/4	476
H	Supply Air Opening Clearance	15/16	24	15/16	24	15/16	24
I	Return Air Opening Side Clearance	1-1/4	32	1-1/4	32	1-1/8	28
J	Return Air Opening Front Clearance	1-1/2	38	1-5/8	41	1-5/8	41
K	Return Air Opening Back Clearance	5/8	16	5/8	16	3/4	19

Outdoor Unit Dimension

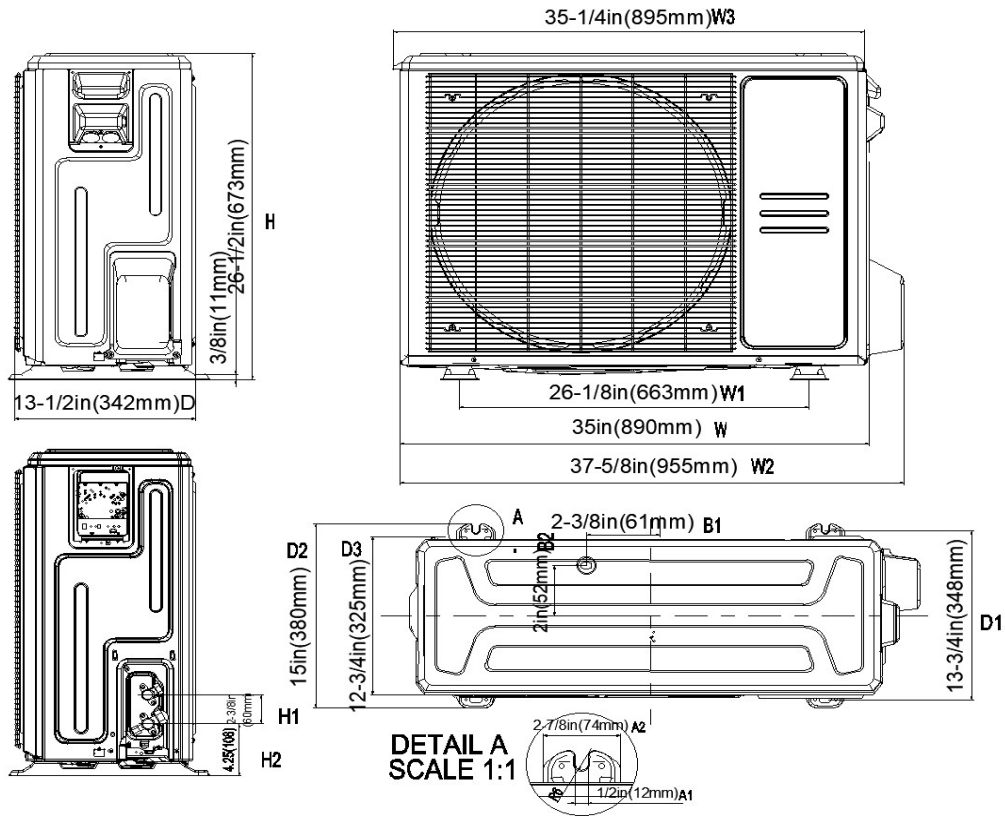

Installation Instruction

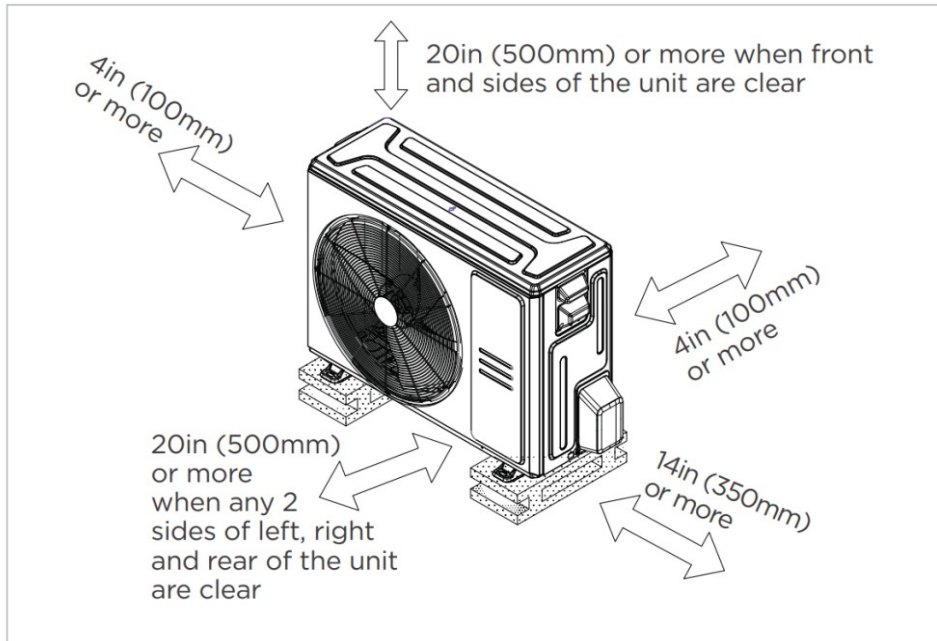

☑ Meets all special requirements shown in Installation Clearance Requirements above.

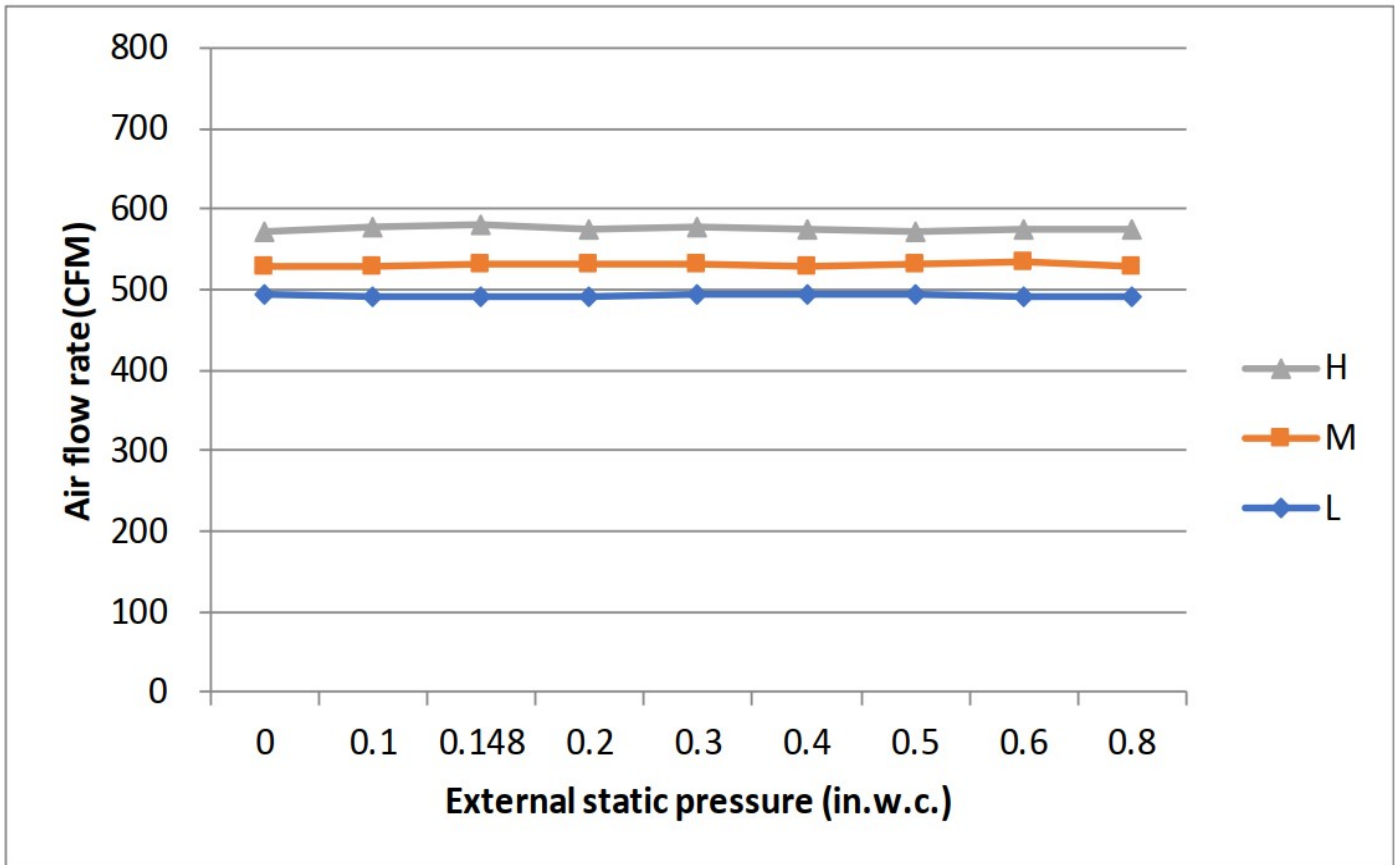

Features

- Multi-position installation: horizontal(left or right), vertical(up or down)
- Aluminum Coil
- Constantly Air Flow system up to 0.80 In.W.G
- 1 inch R4.2 fiberglass free insulation reduces condensation and boosts efficiency(optional)
- Optional Auxiliary heat kit up to 25kW
- Easy Maintenance
- Multiple control options available:
 - Two way communication wired controller:120N(X6)
 - Two way communication wired controller with built-in WiFi:120N(X6W)
 - Wireless remote controller
 - Third-Party 24V Thermostat
- High efficiency up to 18.7 SEER2, 12 EER2, 10 HSPF2
- 100% heat output at 5F*
- Energy Star and Cold Climate Energy Star certified
- Chassis heater and crankcase heater equipped as standard

* Rated cooling capacity/heating capacity at