

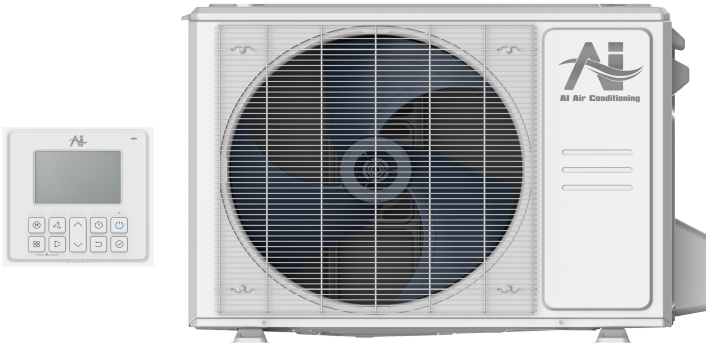

Location: \_\_\_\_\_  
 Engineer: \_\_\_\_\_  
 Submitted to: \_\_\_\_\_  
 Submitted by: \_\_\_\_\_  
 Reference: \_\_\_\_\_

Model Number: AO25-06N2-M1H / AL-06N2-M1

Approval: \_\_\_\_\_  
 Date: \_\_\_\_\_  
 Construction: \_\_\_\_\_  
 Unit #: \_\_\_\_\_  
 Drawing #: \_\_\_\_\_

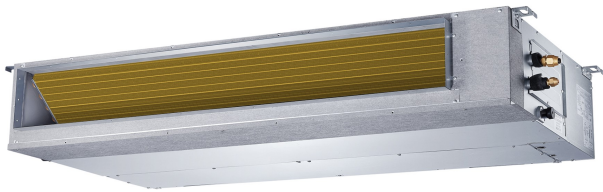

INDOOR SPECIFICATION		
Indoor Air Flow (Turbo/H/M/L/S) (CFM)	324/265/206/147/118	
Indoor Noise Level (T/H/M/L/S) (dBA)	33/33/31/30/22	
Indoor static pressure range	0-0.4	
Dimension (W×D×H)	inch	27-1/2 x 19-7/8 x 7-7/8
	mm	700 x 506 x 200
Package (W×D×H)	inch	33-7/8 x 21-1/4 x 11-1/4
	mm	860 x 540 x 285
Net/Gross Weight	lbs	39/47
	kg	17.9/21.2

OUTDOOR SPECIFICATION		
Compressor Type	ROTARY	
Refrigerant	R454B	
Factory Charge	310ml	
Refrigerant Oil	VG74	
Outdoor Air Flow (Max) (CFM)	1236.1	
Outdoor Noise Level (dBA)	54.0	
Dimension (W×D×H)	inch	30-1/8 x 11-7/8 x 21-7/8
	mm	765 x 303 x 555
Package (W×D×H)	inch	34-7/8 x 13-1/4 x 24
	mm	887 x 337 x 610
Net/Gross Weight	lbs	62/68
	kg	28.2/30.7

EFFICIENCY			
Cooling		Heating	
SEER2	21.4	HSPF2-4	13.8
EER2	14.4	COP	4.0

PERFORMANCE of Cooling	
Cooling (Btu/hr)	
Rated Capacity	6500
Min/Max Capacity	3300~11800
Moisture Removal	0.1
Standard Operating Range	-22°F~-122°F (-30°C~50°C)
Rated Cooling Conditions:	Indoor: 80°F DB/67°F WB Outdoor: 95°F DB/75°F WB

PERFORMANCE of Heating	
Heating (Btu/hr)	
1. @ 47°F Rated (Min/Max)	8000(3700~13100)
2. @ 17°F Rated	8000
3. @ 5°F Max: Capacity / COP	7800/2.40
Standard Operating Range	-22°F~-75°F (-30°C~24°C)
1. Rated Heating Conditions:	Indoor: 70°F DB/60°F WB Outdoor: 47°F DB/43°F WB
2. Rated Heating Conditions:	Indoor: 70°F DB/60°F WB Outdoor: 17°F DB/15°F WB
3. Heating Conditions, Compressor Operating at Max. Frequency	Indoor: 70°F DB/60°F WB Outdoor: 5°F DB/5°F WB

ELECTRICAL	
Power Supply	208/230V,60Hz,1Ph
System MCA	12
Connection Wiring	AWG 14-4
System MOCP	15
Compressor RLA	7.3
Outdoor Fan Motor RLA	0.6
Outdoor Fan Motor W	34
Indoor Fan Motor RLA	1.2
Indoor Fan Motor W	81
System Power Input @ Cooling (W)	448(140 ~ 980)
System Power Input @ Heating (W)	585(240 ~1050)
MCA: Min. circuit amps (A)	MOCP: Max. over current protection (A)
RLA: Rated load amps (A)	W: Fan motor rated output (W)

PIPING	
Liquid Size	1/4in (6.35mm)
Gas Size	3/8in (9.52mm)
Drain Size	5/8in (15.88mm)
Max. Piping Length	82ft (25m)
Max. Height Difference	32.8ft (10m)
Max. Pre-charged Length	24.6ft (7.5m)
Refrigerant Pre-charged Amount	32.45oz (920g)
Additional Charge of Refrigerant	0.16oz/ft (15g/m)
Connection Method	Flared

## Indoor Unit Dimension

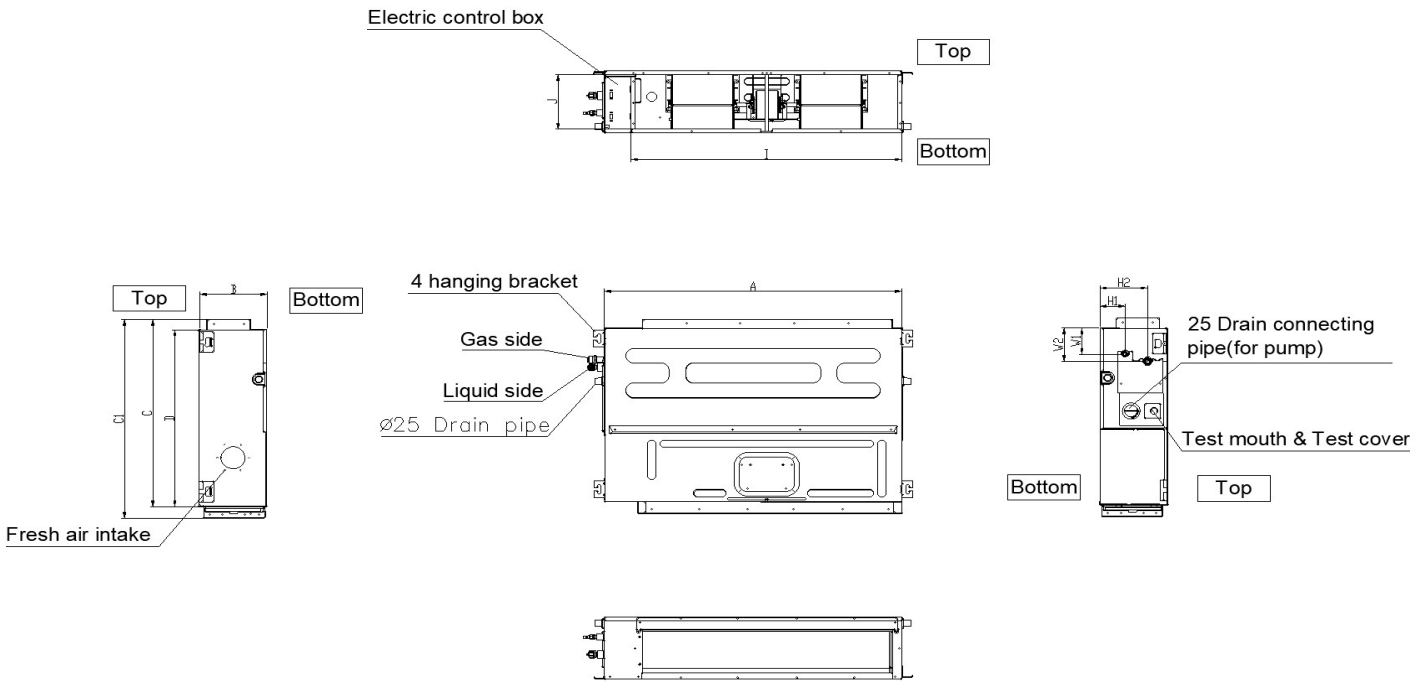

Model(kBtu/h)	unit	A	B	C	C1	D
	6 -12	mm	700	200	470	506
in		27-1/2	7-7/8	18-1/2	20	17-3/4
18	mm	880	210	634	674	600
	in	34-5/8	8-1/4	25	26-1/2	23-5/8

## Installation Instruction

### Installation place

The distance between the mounted indoor unit should meet the specifications illustrated in the following diagram.

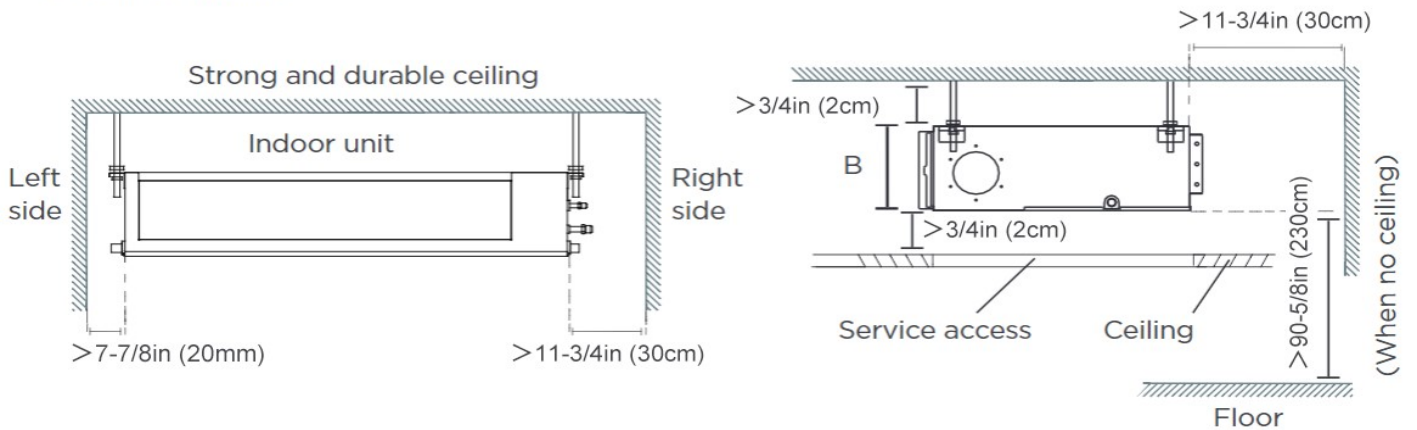

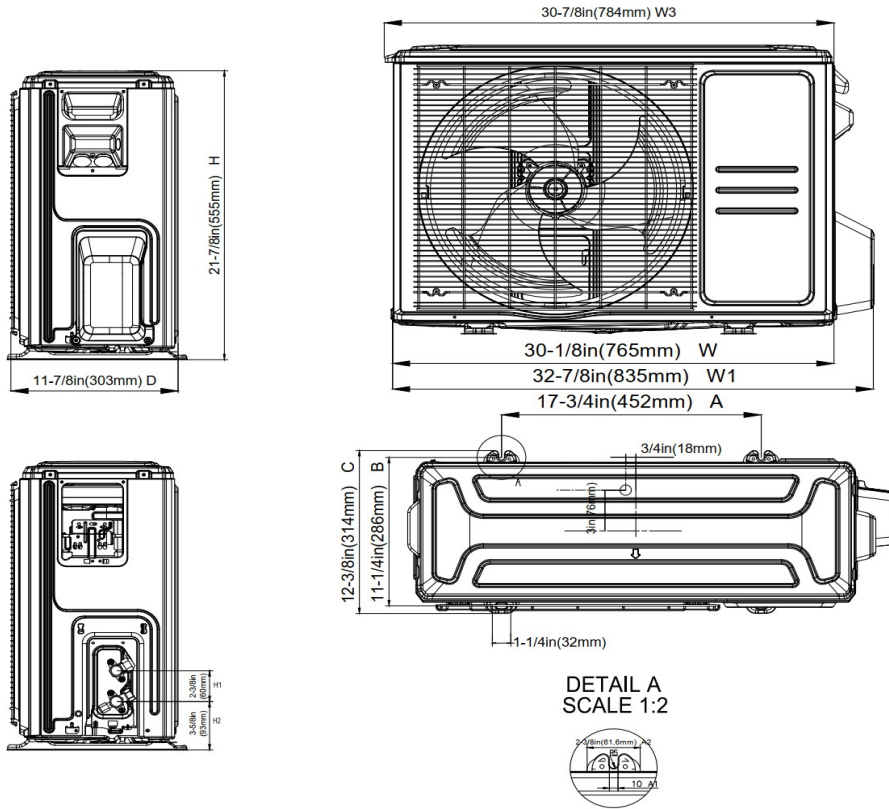

Installation Instruction

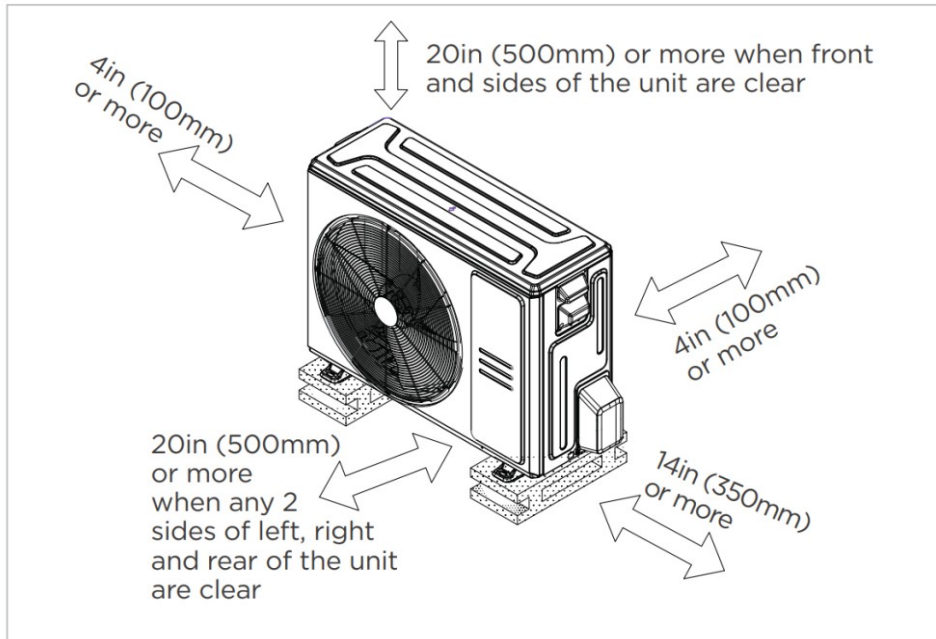

Meets all special requirements shown in Installation Clearance Requirements above.

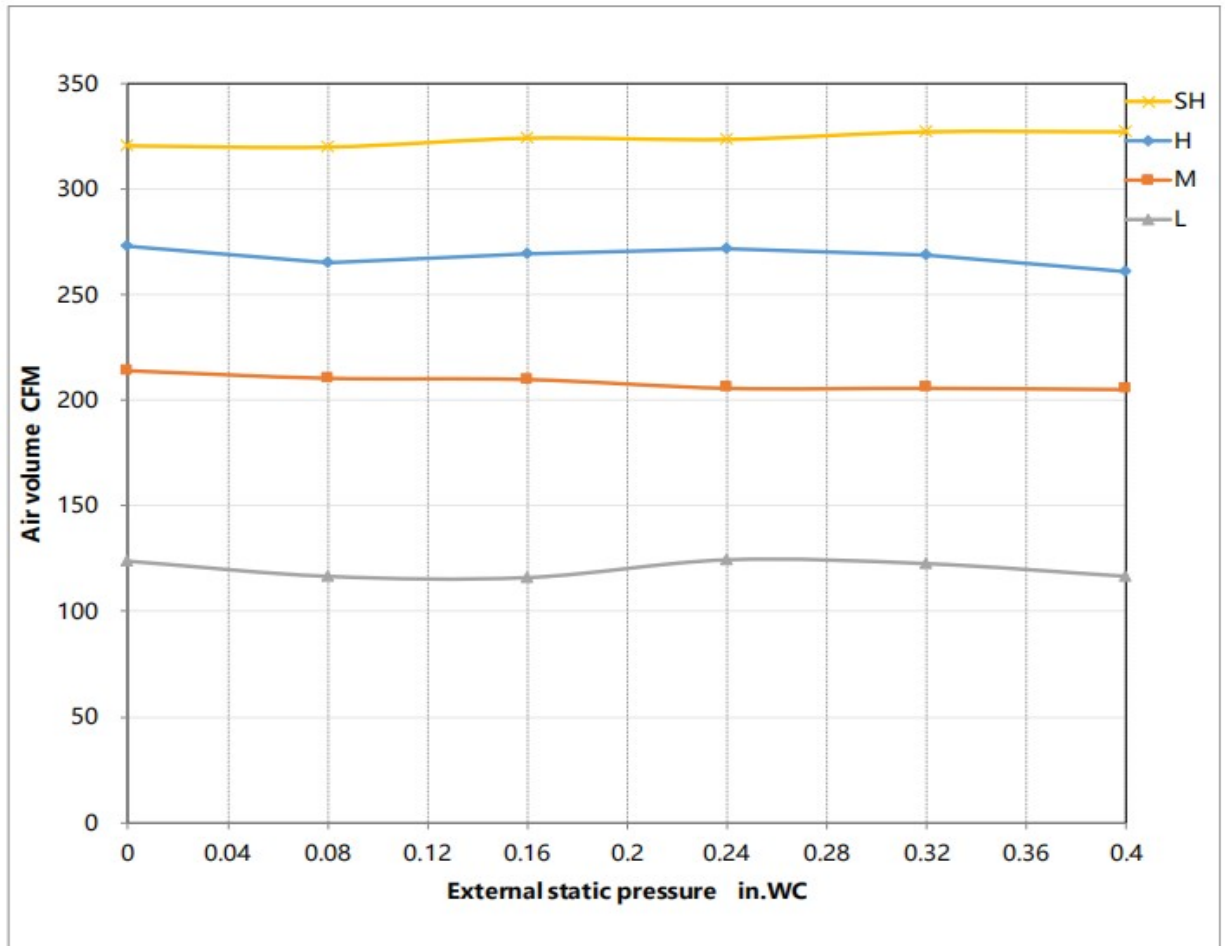
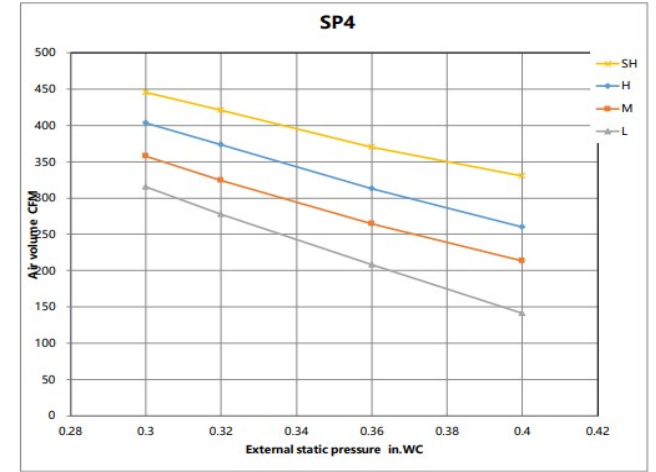
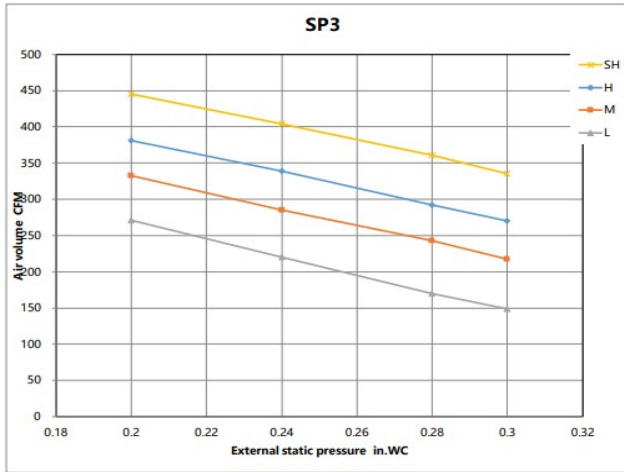
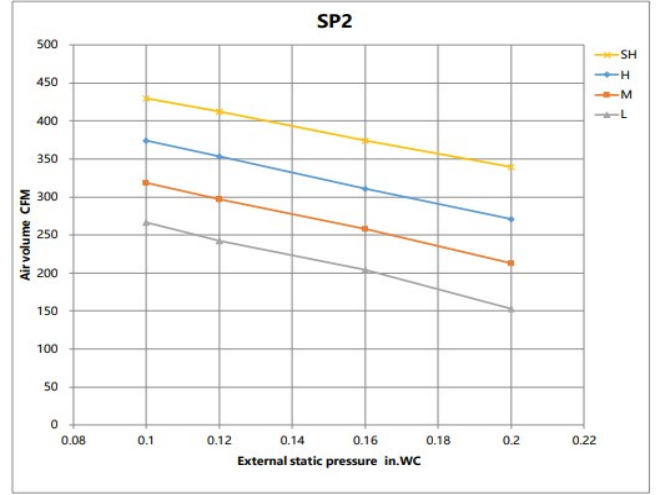
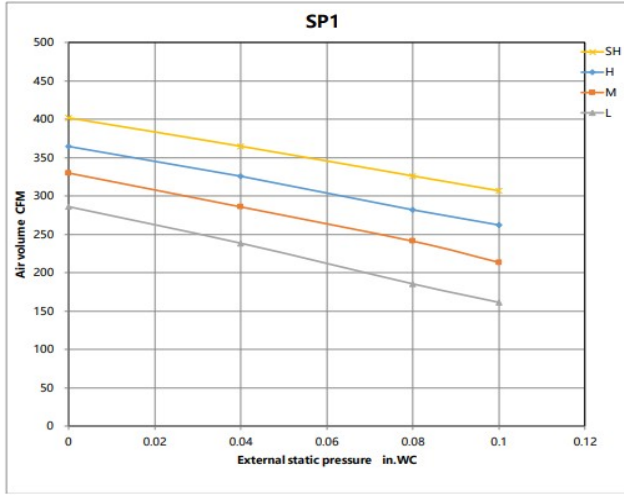

## Features

- Static pressure with 4 levels to select
- Refrigerant leakage detector
- Constant airflow
- Built-in water pump
- i-clean function (AI self cleaning)
- 1~100% stepless adjustable fan speed setting
- WiFi capability: through WiFi module or wired controller with WiFi function
- OTA function: can upgrade the program version via wired controller 120N(X6W)
- 2-pin connector(HA/HB) for programmable wired controller
- Multiple controller options available:
  - Optional two way communication wired controller, programmable:120N(X6)
  - Optional two way communication wired controller, programmable, with built-in WiFi, :120N(X6W)
  - Optional Infrared wired controller: 120L
  - Optional Wireless remote controller
  - Optional 24V interface kit, can connect with Third-Party 24V Thermostat