

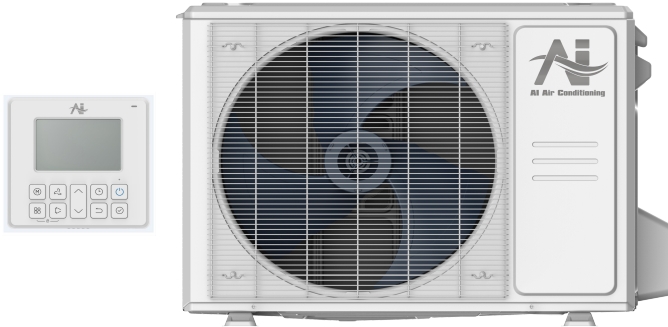

Location: \_\_\_\_\_  
 Engineer: \_\_\_\_\_  
 Submitted to: \_\_\_\_\_  
 Submitted by: \_\_\_\_\_  
 Reference: \_\_\_\_\_

Model Number: AO25-09N2-M1H / AH-09N2-M1

Approval: \_\_\_\_\_  
 Date: \_\_\_\_\_  
 Construction: \_\_\_\_\_  
 Unit #: \_\_\_\_\_  
 Drawing #: \_\_\_\_\_

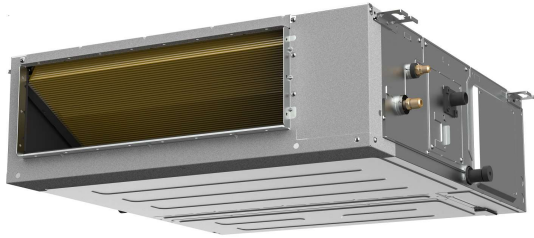

INDOOR SPECIFICATION		
Indoor Air Flow (Turbo/H/M/L/S) (CFM)	344/288/231/201/122	
Indoor Noise Level (T/H/M/L/S) (dBA)	30/30/29/28/26	
Indoor static pressure range	0-0.8	
Dimension (W×D×H)	inch	27-1/2 x 29-1/2 x 9-5/8
	mm	700 x 750 x 245
Package (W×D×H)	inch	36-3/8 x 33-1/2 x 11-3/4
	mm	925 x 850 x 298
Net/Gross Weight	lbs	64/74
	kg	29.1/33.5

OUTDOOR SPECIFICATION		
Compressor Type	ROTARY	
Refrigerant	R454B	
Factory Charge	350ml	
Refrigerant Oil	VG74	
Outdoor Air Flow (Max) (CFM)	1471.5	
Outdoor Noise Level (dBA)	54.0	
Dimension (W×D×H)	inch	31-3/4 x 13 x 21-3/4
	mm	805 x 330 x 554
Package (W×D×H)	inch	36 x 14-5/8 x 24-1/4
	mm	915 x 370 x 615
Net/Gross Weight	lbs	73/79
	kg	33/35.7

EFFICIENCY			
Cooling		Heating	
SEER2	20.5	HSPF2-4	13.8
EER2	14.0	COP	3.9

PERFORMANCE of Cooling	
Cooling (Btu/hr)	
Rated Capacity	9000
Min/Max Capacity	3000~13100
Moisture Removal	0.7
Standard Operating Range	-22°F~122°F (-30°C~50°C)
Rated Cooling Conditions:	Indoor: 80°F DB/67°F WB Outdoor: 95°F DB/75°F WB

PERFORMANCE of Heating	
Heating (Btu/hr)	
1. @ 47°F Rated (Min/Max)	9900(3900~16500)
2. @ 17°F Rated	10200
3. @ 5°F Max: Capacity / COP	11900/1.85
Standard Operating Range	-22°F~75°F (-30°C~24°C)
1. Rated Heating Conditions:	Indoor: 70°F DB/60°F WB Outdoor: 47°F DB/43°F WB
2. Rated Heating Conditions:	Indoor: 70°F DB/60°F WB Outdoor: 17°F DB/15°F WB
3. Heating Conditions, Compressor Operating at Max. Frequency	Indoor: 70°F DB/60°F WB Outdoor: 5°F DB/5°F WB

ELECTRICAL	
Power Supply	208/230V,60Hz,1Ph
System MCA	15
Connection Wiring	AWG 14-4
System MOC	15
Compressor RLA	10.4
Outdoor Fan Motor RLA	0.6
Outdoor Fan Motor W	34
Indoor Fan Motor RLA	1.5
Indoor Fan Motor W	165
System Power Input @ Cooling (W)	642(150 ~ 1260)
System Power Input @ Heating (W)	750(260 ~ 1420)
MCA: Min. circuit amps (A)	MOC: Max. over current protection (A)
RLA: Rated load amps (A)	W: Fan motor rated output (W)

PIPING	
Liquid Size	1/4in (6.35mm)
Gas Size	3/8in (9.52mm)
Drain Size	5/8in (15.88mm)
Max. Piping Length	82ft (25m)
Max. Height Difference	49.2ft (15m)
Max. Pre-charged Length	24.6ft (7.5m)
Refrigerant Pre-charged Amount	35.27oz (1000g)
Additional Charge of Refrigerant	0.16oz/ft (15g/m)
Connection Method	Flared

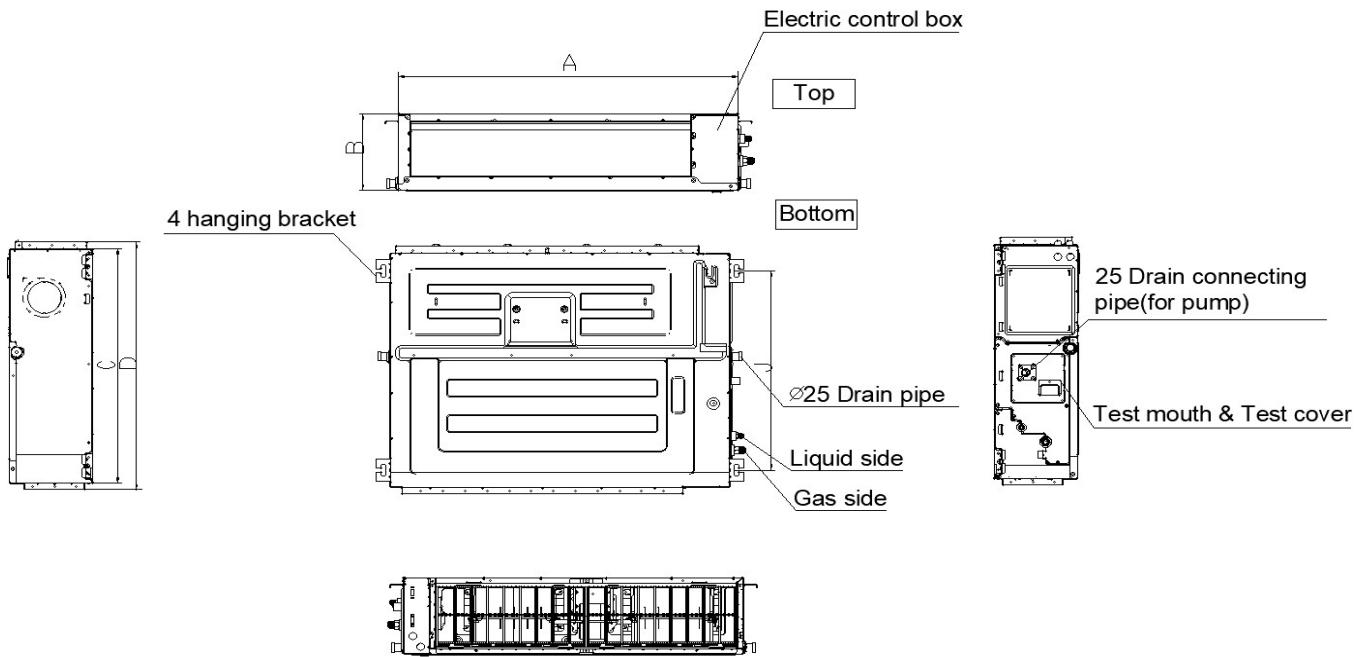

MODEL	A	B	C	D
9K	27-1/2in(700mm)	7-7/8in(200mm)	17-3/4(450mm)	20in(506mm)
12K	27-1/2in(700mm)	9-5/8in(245mm)	29-1/2(750mm)	31-1/4in(795mm)
18K~24K	39-3/8in(1000mm)	9-5/8in(245mm)	29-1/2(750mm)	31-1/4in(795mm)
36K~48K	47-1/8in(1200mm)	11-7/8in(300mm)	29-1/2(750mm)	31-1/4in(795mm)
60K	55-1/8in(1400mm)	15in(380mm)	31-1/2in(800mm)	33-1/4in(845mm)

Installation Instruction

Installation place

The distance between the mounted indoor unit should meet the specifications illustrated in the following diagram.

1) Ceiling-mounted

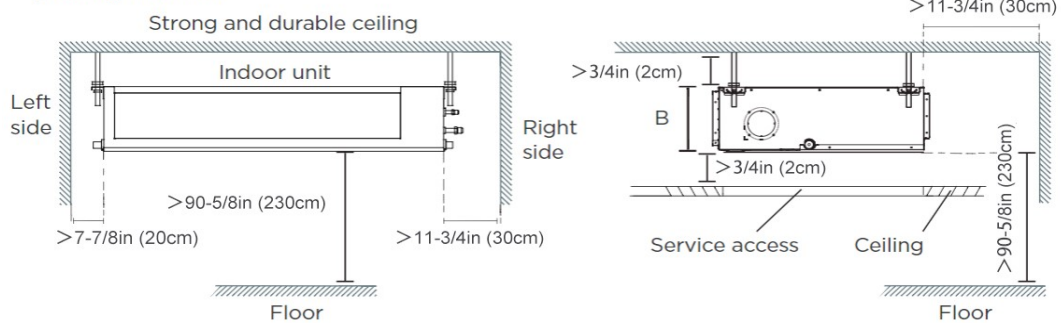

2) Wall-mounted

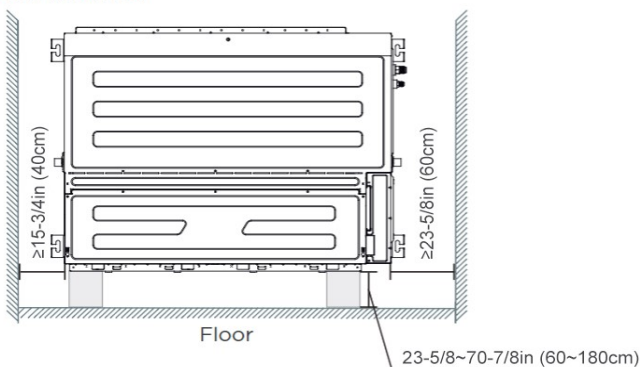

## Outdoor Unit Dimension

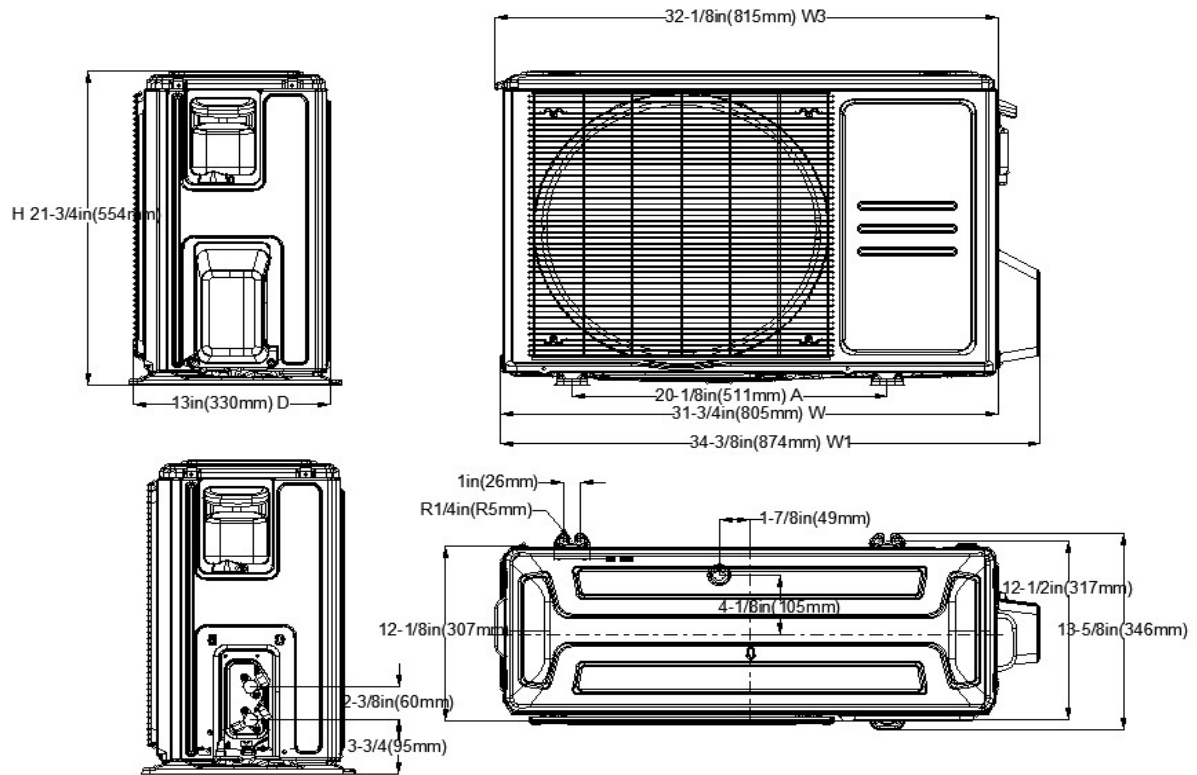

## Installation Instruction

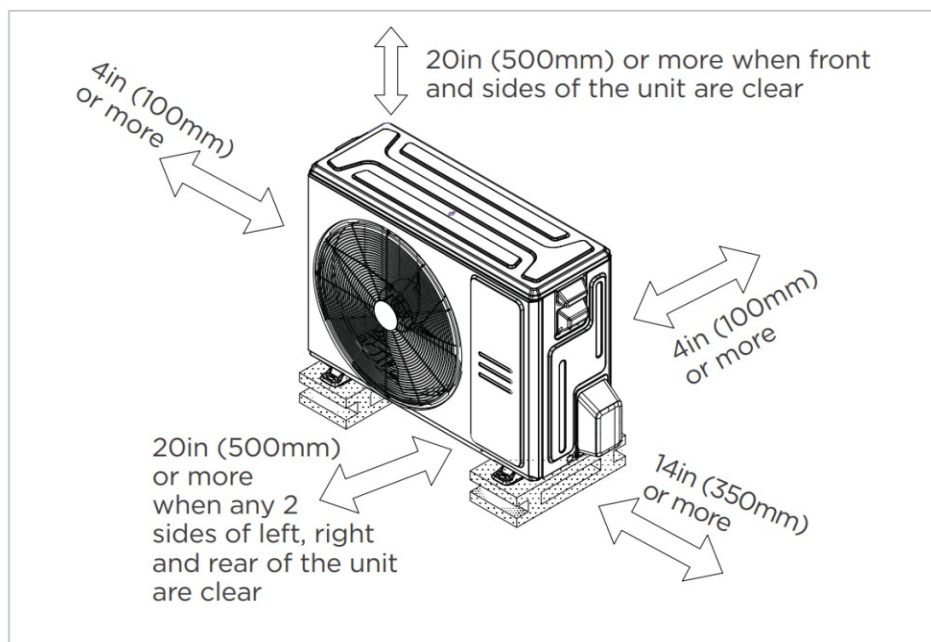

- Meets all special requirements shown in Installation Clearance Requirements above.

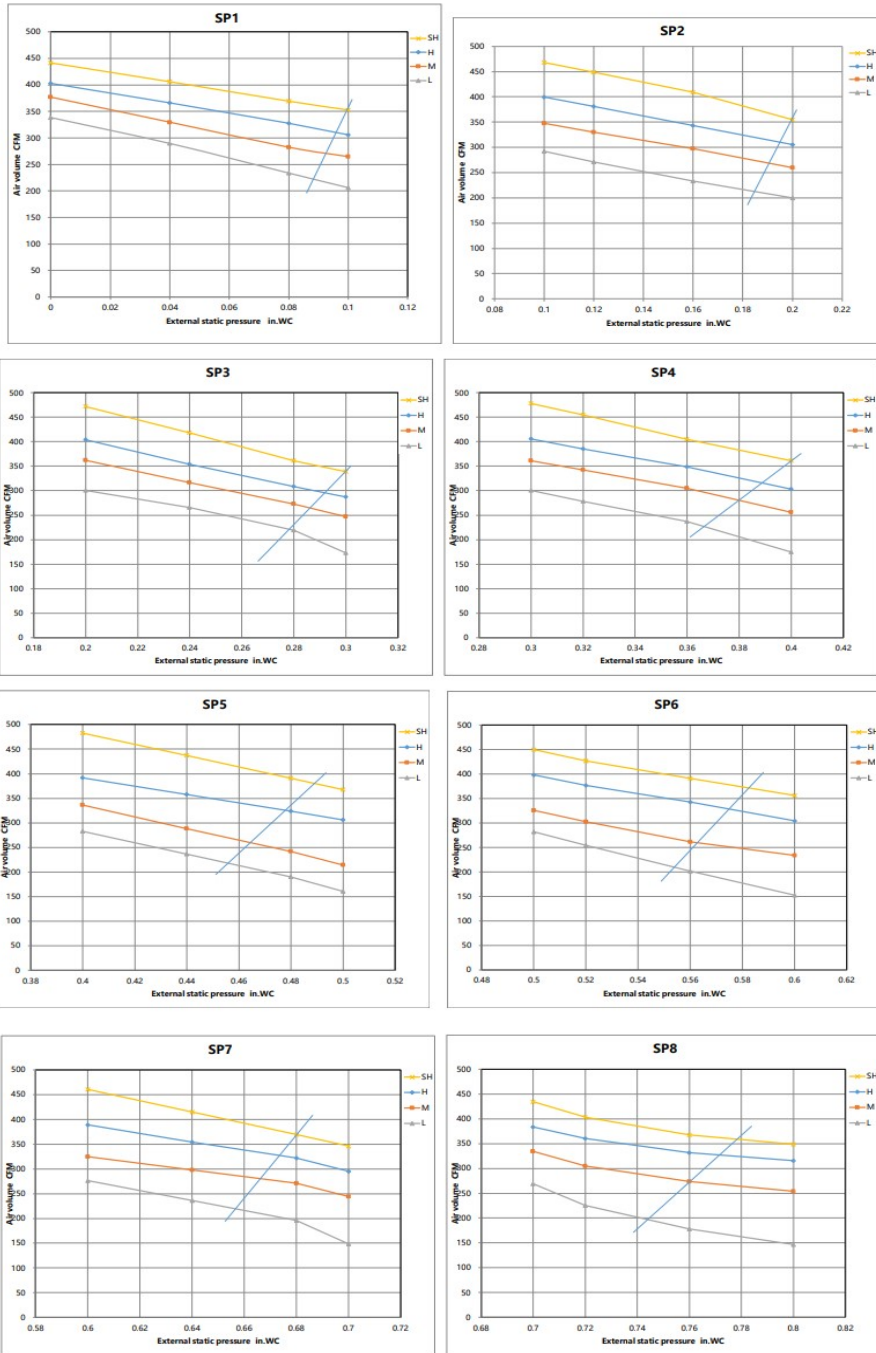

Constant air volume

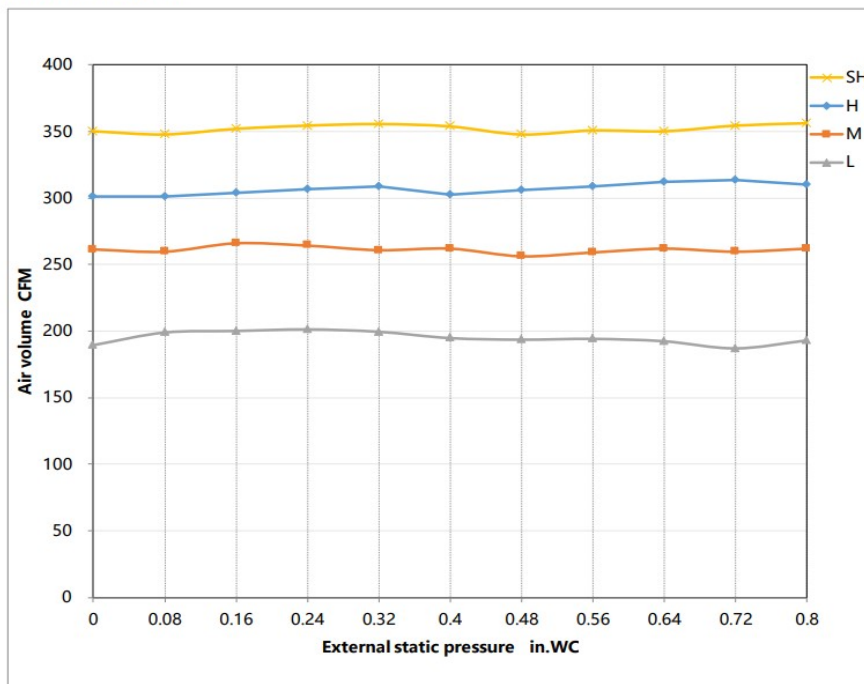

## Features

- Compatible with both horizontal and vertical installation
- Static pressure up to 0.8 in.w.g(for all models)
- Static pressure with 8 levels to select
- Refrigerant leakage detector
- Constant airflow
- Built-in water pump
- i-clean function (AI self cleaning)
- 1~100% stepless adjustable fan speed setting
- WiFi capability: through WiFi module or wired controller with WiFi function
- OTA function: can upgrade the program version via wired controller 120N(X6W)
- 2-pin connector(HA/HB) for programmable wired controller
- Multiple controller options available:
  - Optional two way communication wired controller, programmable:120N(X6)
  - Optional two way communication wired controller, programmable, with built-in WiFi, :120N(X6W)
  - Optional Infrared wired controller: 120L
  - Optional Wireless remote controller
  - Optional 24V interface kit, can connect with Third-Party 24V Thermostat