

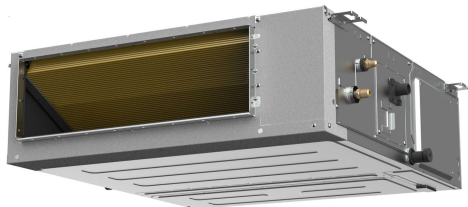

Location: _____
 Engineer: _____
 Submitted to: _____
 Submitted by: _____
 Reference: _____

Model Number: ASO25-60N2-M2H / AH-60N2-M1

Approval: _____
 Date: _____
 Construction: _____
 Unit #: _____
 Drawing #: _____



INDOOR SPECIFICATION	
Indoor Air Flow (Turbo/H/M/L/S) (CFM)	2001/1707/1413/1118/1118
Indoor Noise Level (T/H/M/L/S) (dBA)	52/52/48/42/41
Indoor static pressure range	0-0.8
Dimension (WxDxH)	inch 55-1/8 x 31-1/2 x 15
	mm 1400 x 800 x 380
Package (WxDxH)	inch 63 x 36 x 17-1/2
	mm 1600 x 915 x 445
Net/Gross Weight	lbs 161/178
	kg 73.2/80.8

OUTDOOR SPECIFICATION	
Compressor Type	TWIN-ROTARY
Refrigerant	R454B
Factory Charge	1300ml
Refrigerant Oil	VG75
Outdoor Air Flow (Max) (CFM)	4237.9
Outdoor Noise Level (dBA)	63.0
Dimension (WxDxH)	inch 37-1/2 x 16-3/8 x 52-1/2
	mm 952 x 415 x 1333
Package (WxDxH)	inch 43-1/8 x 19-1/2 x 58-1/4
	mm 1095 x 495 x 1480
Net/Gross Weight	lbs 230/262
	kg 104.5/118.7

EFFICIENCY			
Cooling		Heating	
SEER2	15.8	HSPF2-4	10.4
EER2	10.2	COP	3.7

PERFORMANCE of Cooling	
Cooling (Btu/hr)	
Rated Capacity	55000
Min/Max Capacity	14200~60000
Moisture Removal	3.6
Standard Operating Range	-22°F~122°F (-30°C~50°C)
Rated Cooling Conditions:	Indoor: 80°F DB/67°F WB Outdoor: 95°F DB/75°F WB

PERFORMANCE of Heating	
Heating (Btu/hr)	
1. @ 47°F Rated (Min/Max)	60000(11200~66000)
2. @ 17°F Rated	45000
3. @ 5°F Max: Capacity / COP	53500/2.10
Standard Operating Range	-22°F~75°F (-30°C~24°C)
1. Rated Heating Conditions:	Indoor: 70°F DB/60°F WB Outdoor: 47°F DB/43°F WB
2. Rated Heating Conditions:	Indoor: 70°F DB/60°F WB Outdoor: 17°F DB/15°F WB
3. Heating Conditions, Compressor Operating at Max. Frequency	Indoor: 70°F DB/60°F WB Outdoor: 5°F DB/5°F WB

ELECTRICAL	
Power Supply	208/230V,60Hz,1Ph
System MCA	44
Connection Wiring	AWG 14-3
System MOCP	45
Compressor RLA	26.8
Outdoor Fan Motor RLA	2.2
Outdoor Fan Motor W	85
Indoor Fan Motor RLA	4.0
Indoor Fan Motor W	560
System Power Input @ Cooling (W)	5400(1160 ~ 6120)
System Power Input @ Heating (W)	4700(795 ~5150)
MCA: Min. circuit amps (A)	MOCP: Max. over current protection (A)
RLA: Rated load amps (A)	W: Fan motor rated output (W)

PIPING	
Liquid Size	3/8in (9.52mm)
Gas Size	3/4in (19mm)
Drain Size	5/8in (15.88mm)
Max. Piping Length	246ft (75m)
Max. Height Difference	98.4ft (30m)
Max. Pre-charged Length	24.6ft (7.5m)
Refrigerant Pre-charged Amount	151.68oz (4300g)
Additional Charge of Refrigerant	0.32oz/ft (30g/m)
Connection Method	Flared

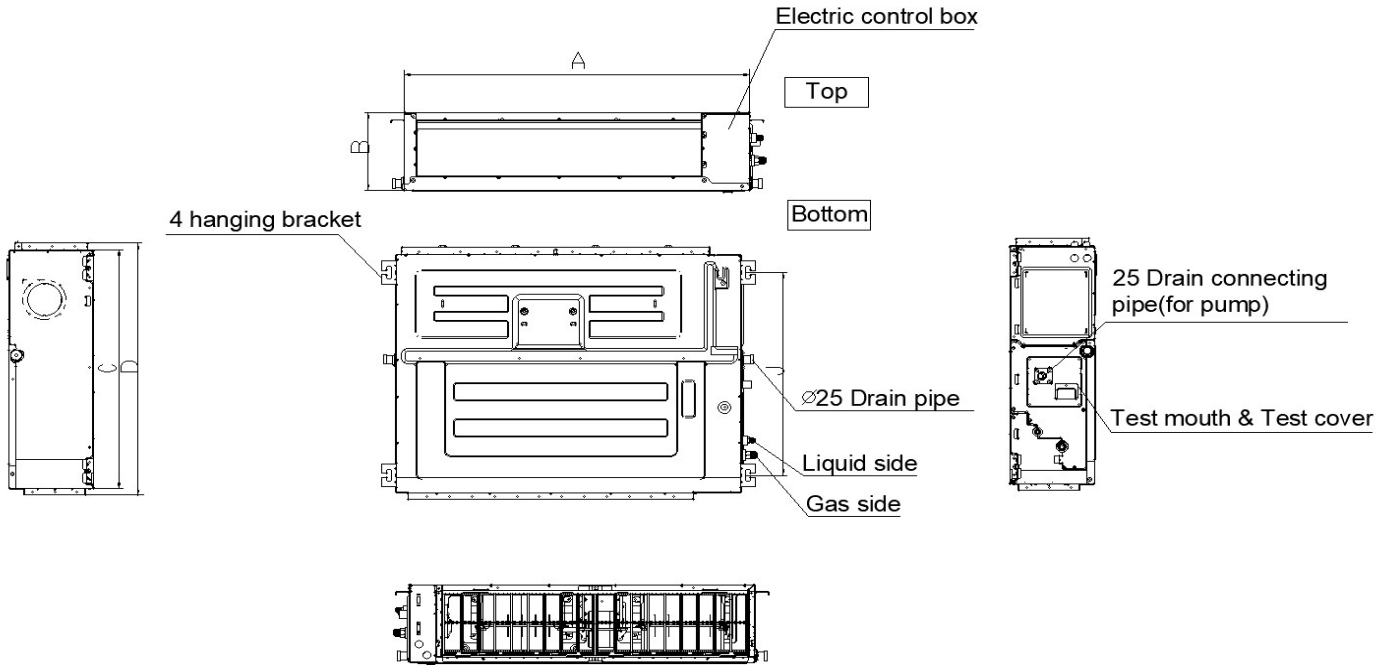

MODEL	A	B	C	D
9K	27-1/2in(700mm)	7-7/8in(200mm)	17-3/4(450mm)	20in(506mm)
12K	27-1/2in(700mm)	9-5/8in(245mm)	29-1/2(750mm)	31-1/4in(795mm)
18K~24K	39-3/8in(1000mm)	9-5/8in(245mm)	29-1/2(750mm)	31-1/4in(795mm)
36K~48K	47-1/8in(1200mm)	11-7/8in(300mm)	29-1/2(750mm)	31-1/4in(795mm)
60K	55-1/8in(1400mm)	15in(380mm)	31-1/2in(800mm)	33-1/4in(845mm)

Installation place

The distance between the mounted indoor unit should meet the specifications illustrated in the following diagram.

1) Ceiling-mounted

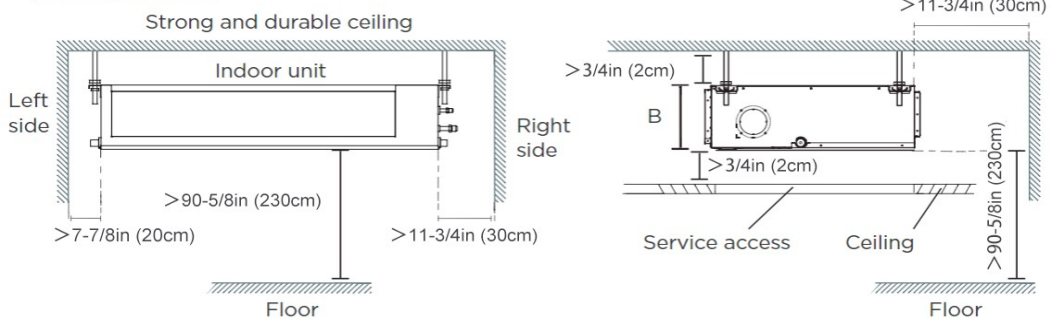

2) Wall-mounted

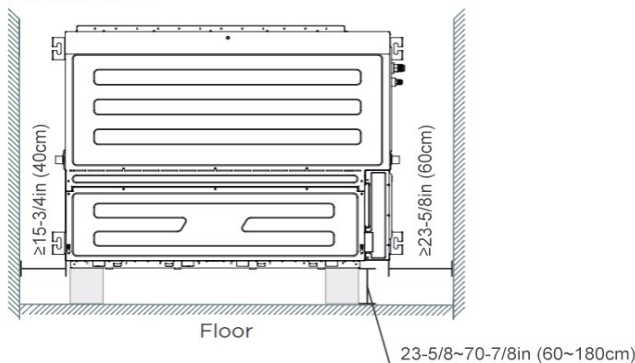

Outdoor Unit Dimension

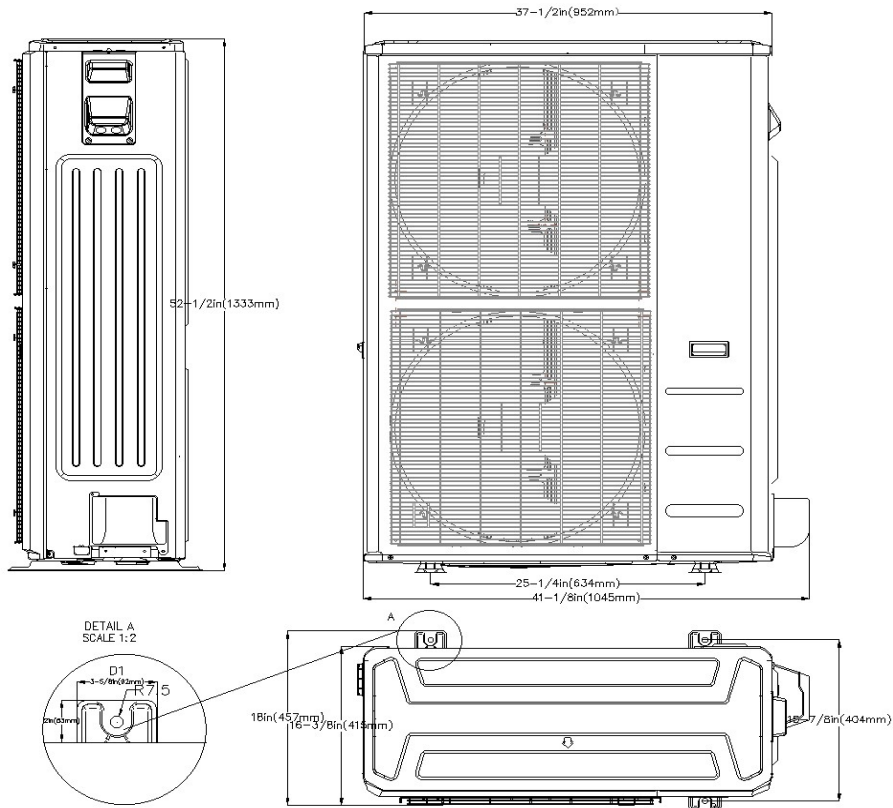

Installation Instruction

REQUIRED CLEARANCE

*1 20in. (500mm) or more when front and sides of the unit are clear

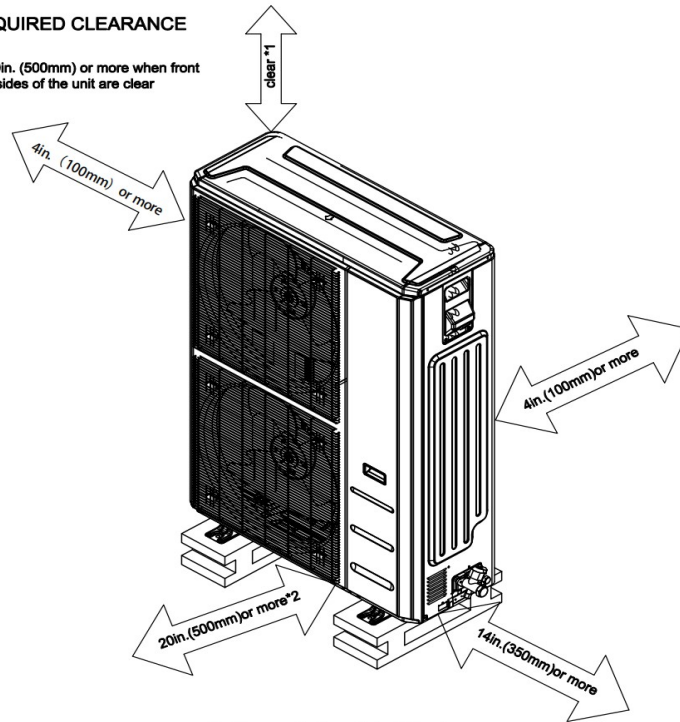

*2 When any 2 sides of left, right and rear of the unit are clear

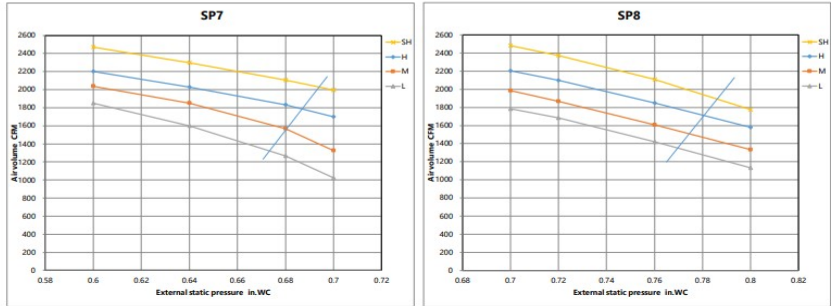
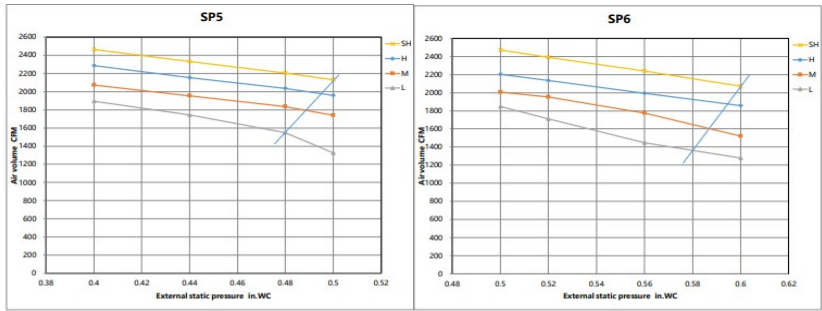
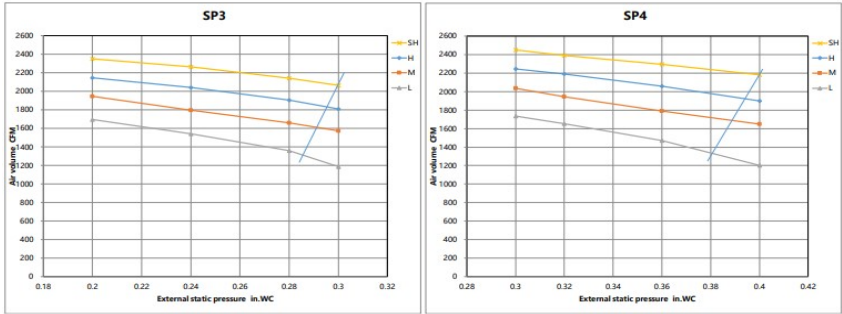
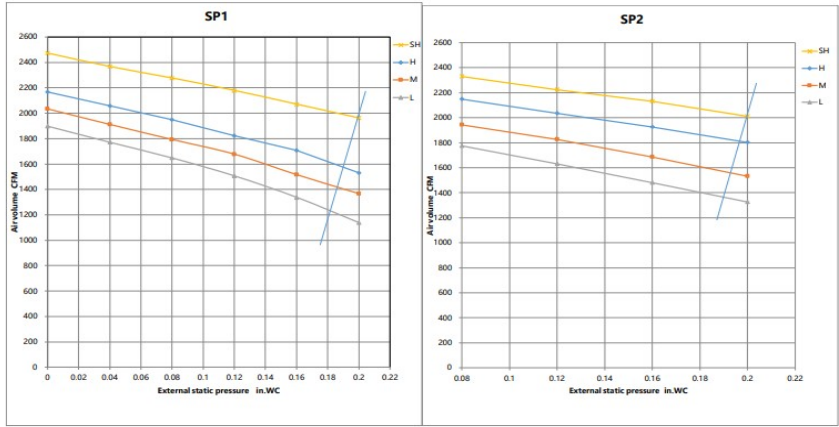

Constant air volume

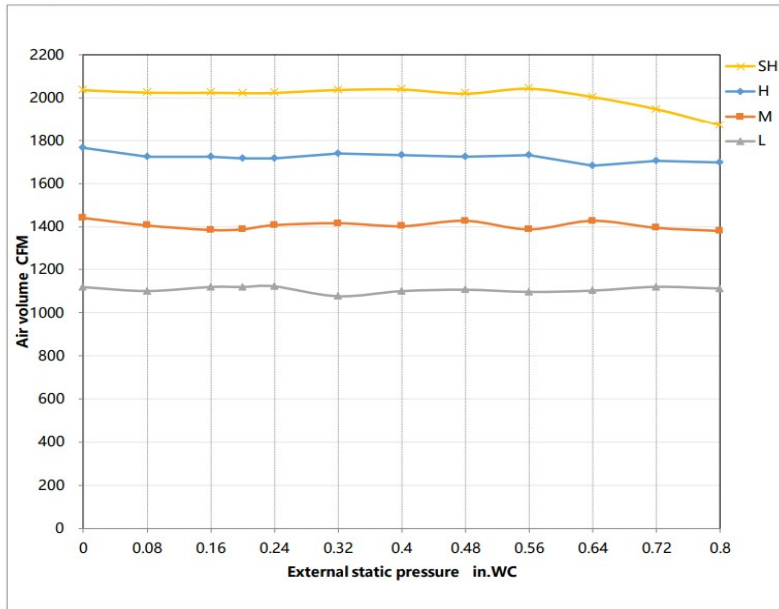

Features

- Compatible with both horizontal and vertical installation
- Static pressure up to 0.8 in.w.g(for all models)
- Static pressure with 8 levels to select
- Refrigerant leakage detector
- Constant airflow
- Built-in water pump
- i-clean function (AI self cleaning)
- 1~100% stepless adjustable fan speed setting
- WiFi capability: through WiFi module or wired controller with WiFi function
- OTA function: can upgrade the program version via wired controller 120N(X6W)
- 2-pin connector(HA/HB) for programmable wired controller
- Multiple controller options available:
 - Optional two way communication wired controller, programmable:120N(X6)
 - Optional two way communication wired controller, programmable, with built-in WiFi, :120N(X6W)
 - Optional Infrared wired controller: 120L
 - Optional Wireless remote controller
 - Optional 24V interface kit, can connect with Third-Party 24V Thermostat