



Location: _____
 Engineer: _____
 Submitted to: _____
 Submitted by: _____
 Reference: _____

Model Number: A3MO21-18N2-M1
 Approval: _____
 Date: _____
 Construction: _____
 Unit #: _____
 Drawing #: _____



OUTDOOR SPECIFICATION		
Compressor Type	Twin-ROTARY	
Refrigerant	R454B	
Factory Charge	450ml	
Refrigerant Oil	VG74	
Outdoor Air Flow (Max) (CFM)	1766	
Outdoor Noise Level (dBA)	60.0	
Dimension (W×D×H)	inch	35 x 13-1/2 x 26-1/2
	mm	890 x 342 x 673
Package (W×D×H)	inch	40-1/2 x 17-1/4 x 29-1/2
	mm	1030 x 438 x 750
Net/Gross Weight	lbs	101/109
	kg	45.6/49.6

EFFICIENCY			
Cooling		Heating	
SEER2	23.0	HSPF2-4	10.0
EER2	12.5	COP	3.8

PERFORMANCE of Cooling	
Cooling (Btu/hr)	
Rated Capacity	18000
Min/Max Capacity	5400~21600
Moisture Removal	1.3
Standard Operating Range	-13°F~122°F (-25°C~50°C)
Rated Cooling Conditions:	Indoor: 80°F DB/67°F WB Outdoor: 95°F DB/75°F WB

PERFORMANCE of Heating	
Heating (Btu/hr)	
1. @ 47°F Rated (Min/Max)	19000(5700~21600)
2. @ 17°F Rated	13500
3. @ 5°F Max: Capacity / COP	13500/2.2
Standard Operating Range	-13°F~75°F (-25°C~24°C)
1. Rated Heating Conditions:	Indoor: 70°F DB/60°F WB Outdoor: 47°F DB/43°F WB
2. Rated Heating Conditions:	Indoor: 70°F DB/60°F WB Outdoor: 17°F DB/15°F WB
3. Heating Conditions, Compressor Operating at Max. Frequency	Indoor: 70°F DB/60°F WB Outdoor: 5°F DB/5°F WB

ELECTRICAL	
Power Supply	208/230V,60Hz,1Ph
System MCA	16
Connection Wiring	AWG 14-4
System MOCP	20
Compressor RLA	8.2
Outdoor Fan Motor RLA	1
Outdoor Fan Motor W	80
Indoor Fan Motor RLA	/
Indoor Fan Motor W	/
System Power Input @ Cooling (W)	1440/(400 ~ 1900)
System Power Input @ Heating (W)	1465/(350 ~ 1900)
MCA: Min. circuit amps (A)	MOCP: Max. over current protection (A)
RLA: Rated load amps (A)	W: Fan motor rated output (W)

PIPING	
Liquid Size	3x1/4in (3x6.35mm)
Gas Size	3x3/8in (3x9.52mm)
Drain Size	5/8in (15.88mm)
Max. Piping Length for all rooms	196.8ft (60m)
Max. Piping Length for one IDU	98.4ft (30m)
Max. Height Difference of IDU and ODU	49.2ft (15m)
Refrigerant Pre-charged Amount	61.73oz (1750g)
Refrigerant Precharge Length	24.6ft (7.5m)x3
Additional Charge of Refrigerant (Φ6.35 (1/4") liquid pipe)	0.16oz/ft (15g/m)
Additional Charge of Refrigerant (Φ9.52 (3/8") liquid pipe)	0.32oz/ft(30g/m)
Connection Method	Flared

Outdoor Unit Dimension

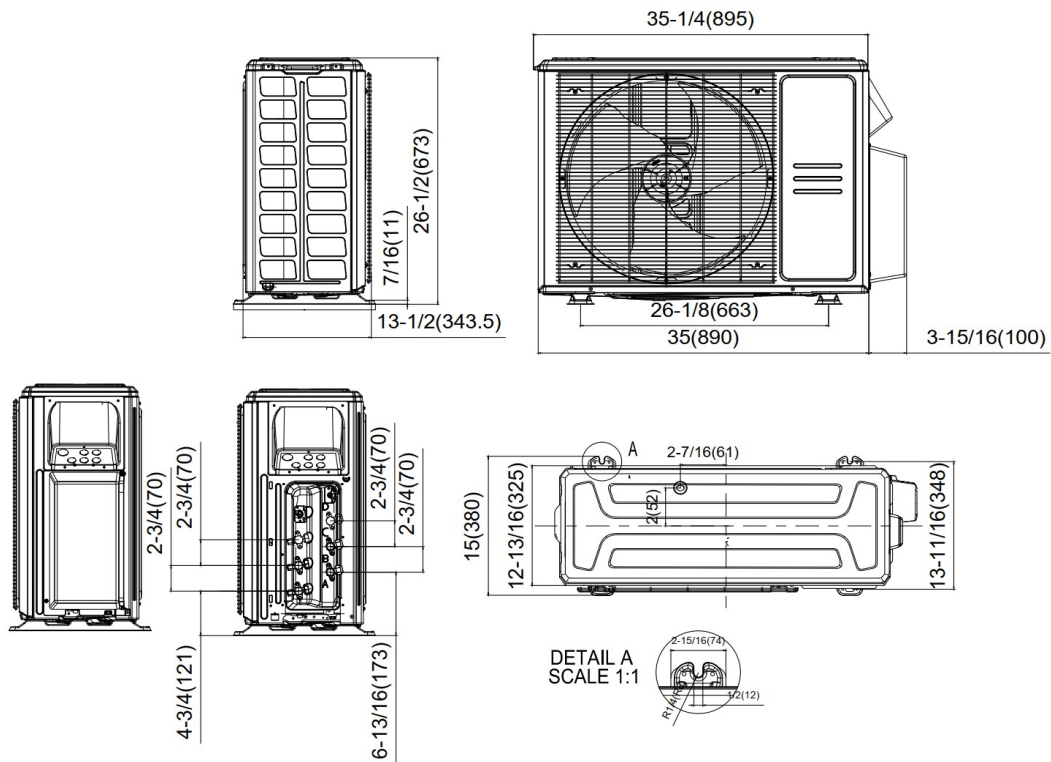

Installation Instruction

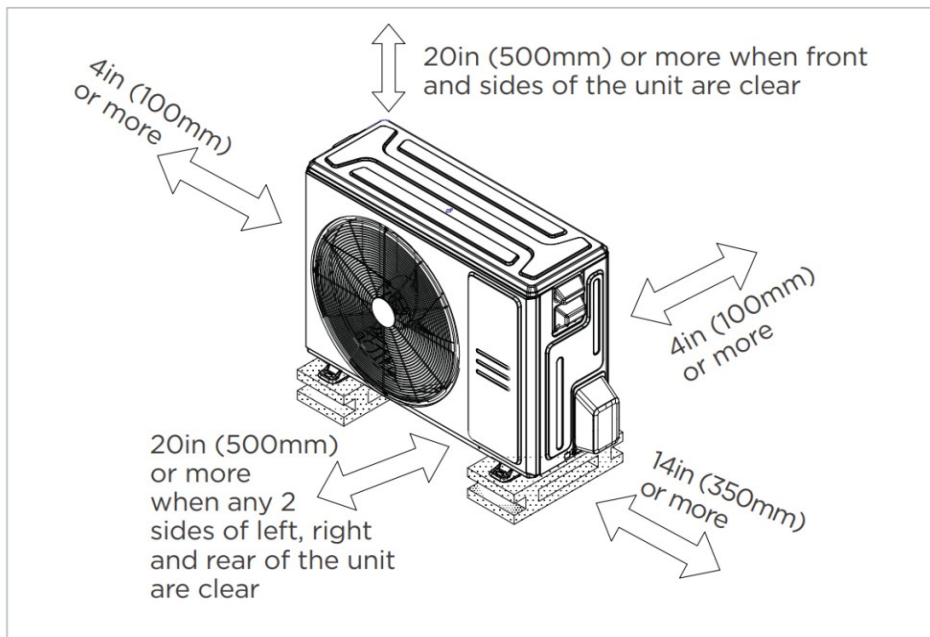

Meets all special requirements shown in Installation Clearance Requirements above.