



Location: _____
 Engineer: _____
 Submitted to: _____
 Submitted by: _____
 Reference: _____

Model Number: A4MO21-27N2-M1

Approval: _____
 Date: _____
 Construction: _____
 Unit #: _____
 Drawing #: _____



OUTDOOR SPECIFICATION		
Compressor Type		ROTARY
Refrigerant		R454B
Factory Charge		620ml
Refrigerant Oil		VG74
Outdoor Air Flow (Max) (CFM)		2131
Outdoor Noise Level (dBA)		61.0
Dimension (W×D×H)	inch	37-1/4 x 16-1/8 x 31-7/8
	mm	946 x 410 x 810
Package (W×D×H)	inch	42-7/8 x 19-5/8 x 34-7/8
	mm	1090 x 500 x 885
Net/Gross Weight	lbs	139/150
	kg	63.0/67.9

EFFICIENCY			
Cooling		Heating	
SEER2	21.0	HSPF2-4	9.0
EER2	12.0	COP	3.6

PERFORMANCE of Cooling	
Cooling (Btu/hr)	
Rated Capacity	26600
Min/Max Capacity	7200~32000
Moisture Removal	0.8
Standard Operating Range	-13°F~122°F (-25°C~50°C)

Rated Cooling Conditions: Indoor: 80°F DB/67°F WB
 Outdoor: 95°F DB/75°F WB

PERFORMANCE of Heating	
Heating (Btu/hr)	
1. @ 47°F Rated (Min/Max)	26600(8400~28000)
2. @ 17°F Rated	18400
3. @ 5°F Max: Capacity / COP	18800/2
Standard Operating Range	-13°F~75°F (-25°C~24°C)

1. Rated Heating Conditions: Indoor: 70°F DB/60°F WB
 Outdoor: 47°F DB/43°F WB

2. Rated Heating Conditions: Indoor: 70°F DB/60°F WB
 Outdoor: 17°F DB/15°F WB

3. Heating Conditions, Compressor Operating at Max. Frequency Indoor: 70°F DB/60°F WB
 Outdoor: 5°F DB/5°F WB

ELECTRICAL	
Power Supply	208/230V,60Hz,1Ph
System MCA	23
Connection Wiring	AWG 14-4
System MOC	25
Compressor RLA	12.1
Outdoor Fan Motor RLA	1.2
Outdoor Fan Motor W	120
Indoor Fan Motor RLA	/
Indoor Fan Motor W	/
System Power Input @ Cooling (W)	2215/(500 ~ 2960)
System Power Input @ Heating (W)	2165/(500 ~2300)
MCA: Min. circuit amps (A)	MOC: Max. over current protection (A)
RLA: Rated load amps (A)	W: Fan motor rated output (W)

PIPING	
Liquid Size	4x1/4in (4x6.35mm)
Gas Size	3x3/8in+1x1/2in (3x9.52mm+1x12.7mm)
Drain Size	5/8in (15.88mm)
Max. Piping Length for all rooms	262.4ft (80m)
Max. Piping Length for one IDU	114.8ft (35m)
Max. Height Difference of IDU and ODU	49.2ft (15m)
Refrigerant Pre-charged Amount	84.66oz (2400g)
Refrigerant Precharge Length	24.6ft (7.5m)x4
Additional Charge of Refrigerant (Φ6.35 (1/4") liquid pipe)	0.16oz/ft (15g/m)
Additional Charge of Refrigerant (Φ9.52 (3/8") liquid pipe)	0.32oz/ft (30g/m)
Connection Method	Flared

Outdoor Unit Dimension

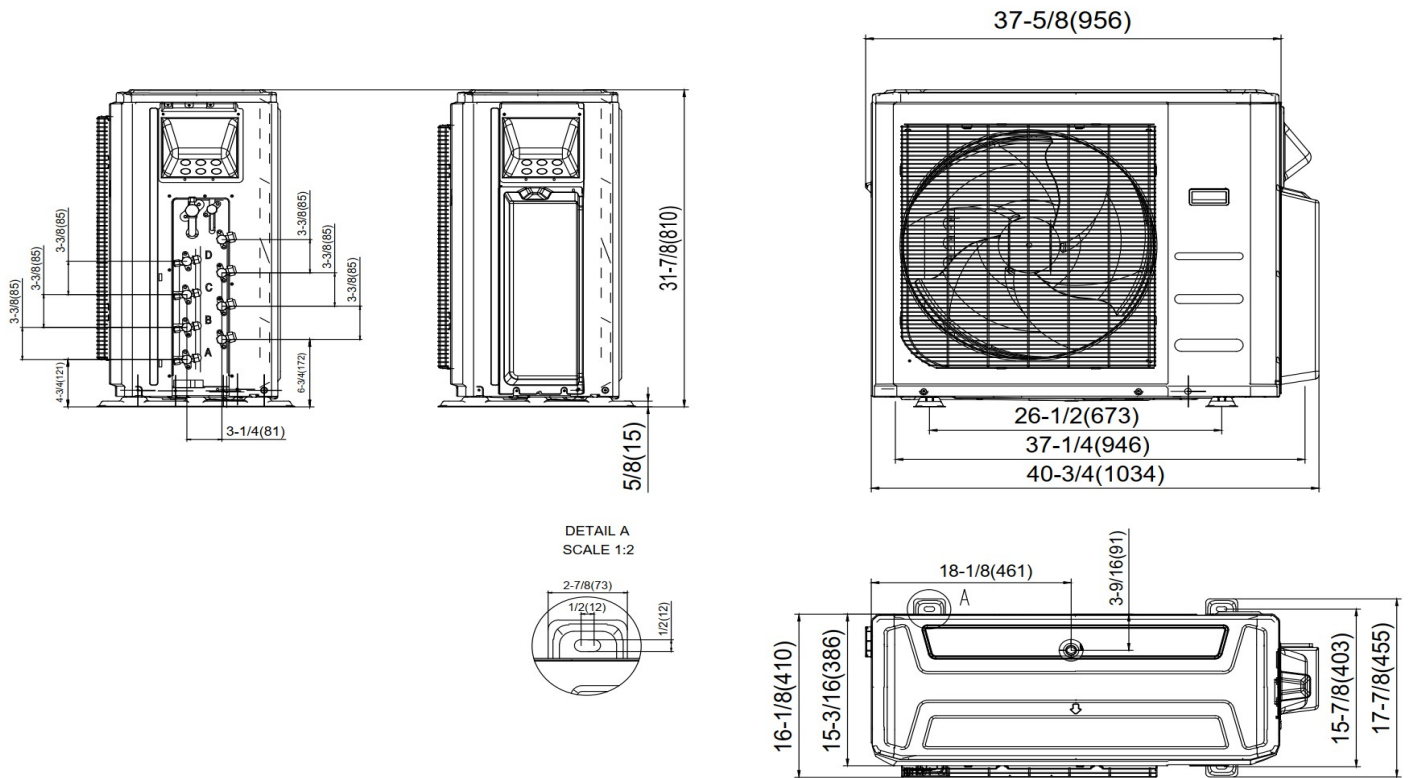

Installation Instruction

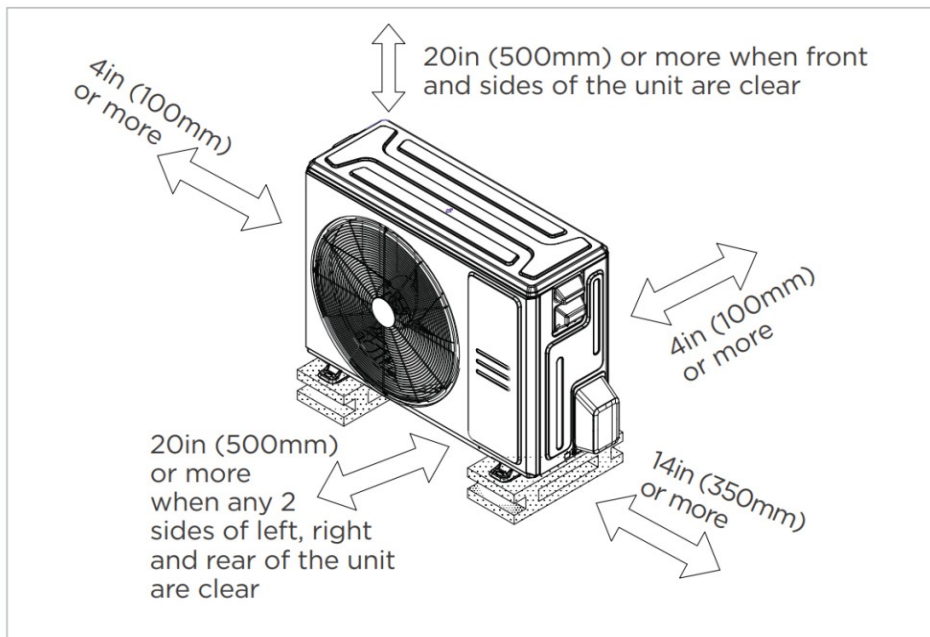

- Meets all special requirements shown in Installation Clearance Requirements above.