



Location: _____
 Engineer: _____
 Submitted to: _____
 Submitted by: _____
 Reference: _____

Model Number: A3MO23-18N2-M1H
 Approval: _____
 Date: _____
 Construction: _____
 Unit #: _____
 Drawing #: _____



OUTDOOR SPECIFICATION		
Compressor Type	ROTARY	
Refrigerant	R454B	
Factory Charge	620ml	
Refrigerant Oil	VG74	
Outdoor Air Flow (Max) (CFM)	2131	
Outdoor Noise Level (dBA)	62.0	
Dimension (W×D×H)	inch	37-1/4 x 16-1/8 x 31-7/8
	mm	946 x 410 x 810
Package (W×D×H)	inch	42-7/8 x 19-5/8 x 34-7/8
	mm	1090 x 500 x 885
Net/Gross Weight	lbs	137/148
	kg	62.3/67.2

ELECTRICAL	
Power Supply	208/230V,60Hz,1Ph
System MCA	17.5
Connection Wiring	AWG 14-4
System MOC	20
Compressor RLA	9.2
Outdoor Fan Motor RLA	1.2
Outdoor Fan Motor W	120
Indoor Fan Motor RLA	/
Indoor Fan Motor W	/
System Power Input @ Cooling (W)	1460/(400 ~ 2300)
System Power Input @ Heating (W)	1503/(350 ~2300)
MCA: Min. circuit amps (A)	MOC: Max. over current protection (A)
RLA: Rated load amps (A)	W: Fan motor rated output (W)

EFFICIENCY			
Cooling		Heating	
SEER2	21.0	HSPF2-4	10.0
EER2	13.0	COP	3.9

PERFORMANCE of Cooling	
Cooling (Btu/hr)	
Rated Capacity	19000
Min/Max Capacity	5400~27600
Moisture Removal	1.4
Standard Operating Range	-22°F~-122°F (-30°C~50°C)
Rated Cooling Conditions:	Indoor: 80°F DB/67°F WB Outdoor: 95°F DB/75°F WB

PERFORMANCE of Heating	
Heating (Btu/hr)	
1. @ 47°F Rated (Min/Max)	20000(5700~25400)
2. @ 17°F Rated	16400
3. @ 5°F Max: Capacity / COP	18000/2
Standard Operating Range	-22°F~-75°F (-30°C~24°C)
1. Rated Heating Conditions:	Indoor: 70°F DB/60°F WB Outdoor: 47°F DB/43°F WB
2. Rated Heating Conditions:	Indoor: 70°F DB/60°F WB Outdoor: 17°F DB/15°F WB
3. Heating Conditions, Compressor Operating at Max. Frequency	Indoor: 70°F DB/60°F WB Outdoor: 5°F DB/5°F WB

PIPING	
Liquid Size	3x1/4in (3x6.35mm)
Gas Size	3x3/8in (3x9.52mm)
Drain Size	5/8in (15.88mm)
Max. Piping Length for all rooms	196.8ft (60m)
Max. Piping Length for one IDU	98.4ft (30m)
Max. Height Difference of IDU and ODU	49.2ft (15m)
Refrigerant Pre-charged Amount	78.31oz (2220g)
Refrigerant Precharge Length	24.6ft (7.5m)x3
Additional Charge of Refrigerant (Φ6.35 (1/4") liquid pipe)	0.16oz/ft (15g/m)
Additional Charge of Refrigerant (Φ9.52 (3/8") liquid pipe)	0.32oz/ft (30g/m)
Connection Method	Flared

Outdoor Unit Dimension

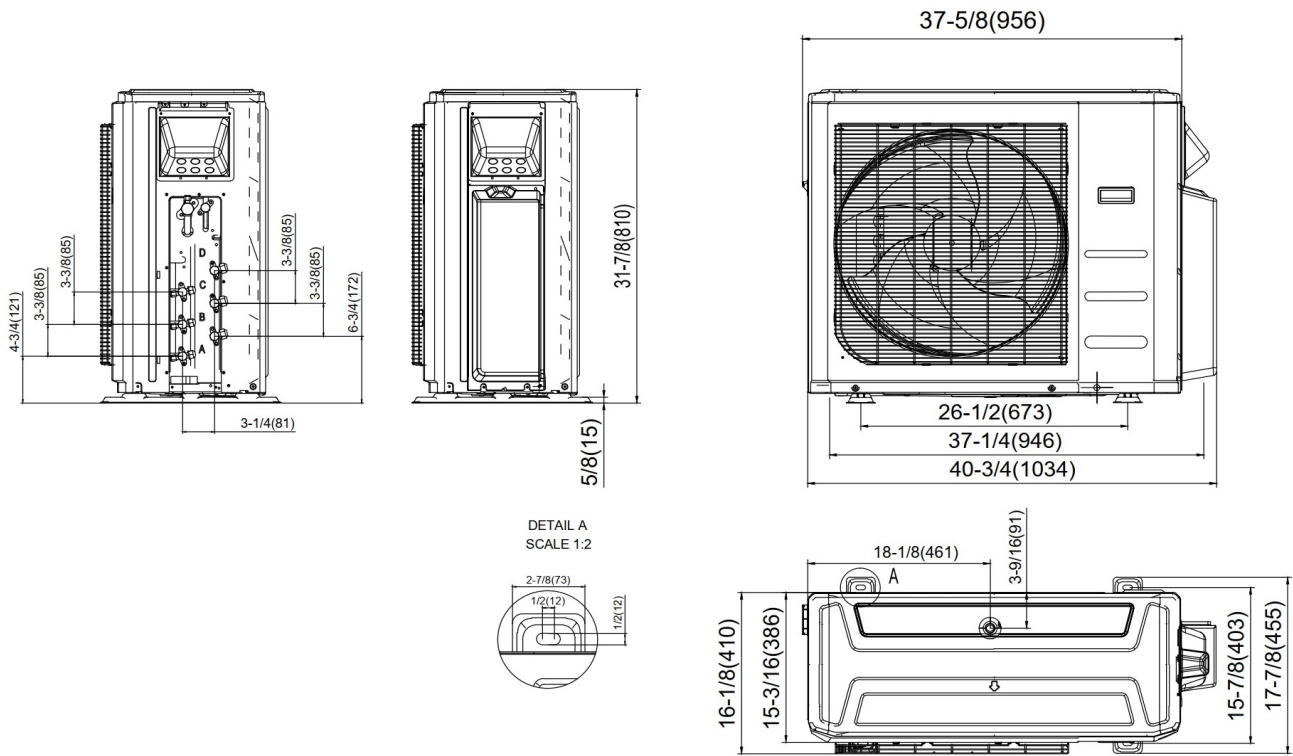

Installation Instruction

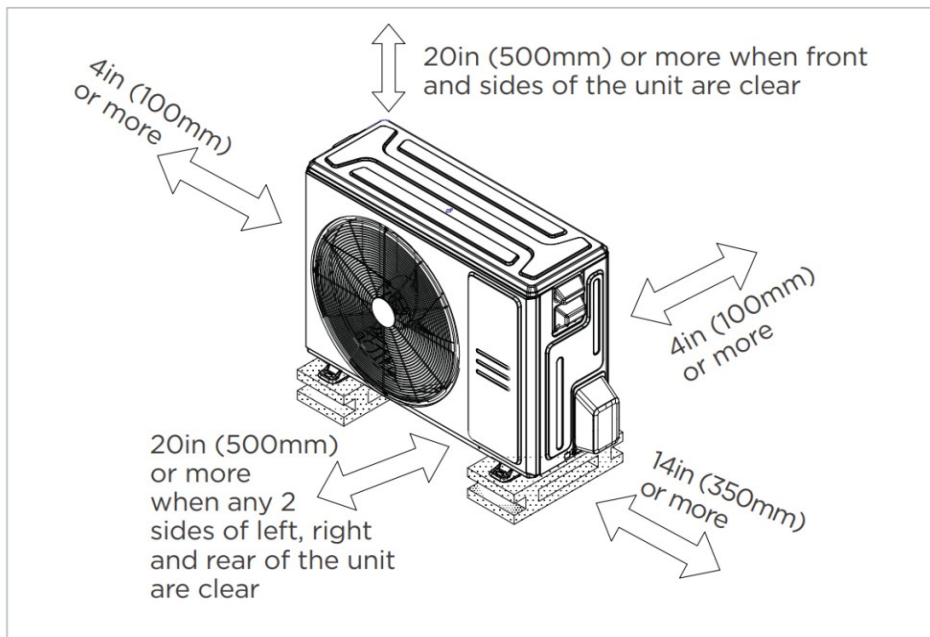

- Meets all special requirements shown in Installation Clearance Requirements above.