

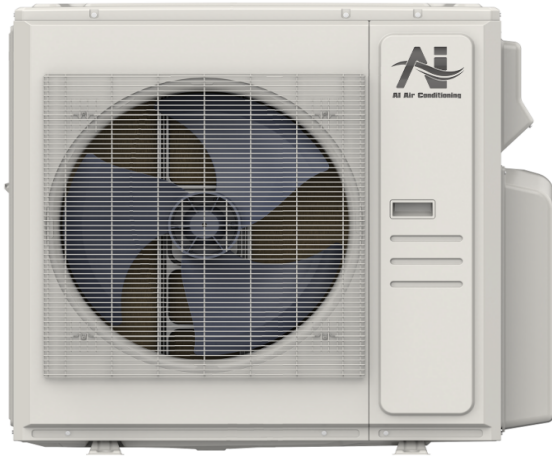

Location: _____
 Engineer: _____
 Submitted to: _____
 Submitted by: _____
 Reference: _____

Model Number: A5MO23-36N2-M1H
 Approval: _____
 Date: _____
 Construction: _____
 Unit #: _____
 Drawing #: _____



OUTDOOR SPECIFICATION		
Compressor Type	TWIN-ROTARY	
Refrigerant	R454B	
Factory Charge	1460ml	
Refrigerant Oil	VG75	
Outdoor Air Flow (Max) (CFM)	3037	
Outdoor Noise Level (dBA)	65.0	
Dimension (W×D×H)	inch	38-5/8 x 16-3/8 x 38-3/8
	mm	980 x 415 x 975
Package (W×D×H)	inch	45-1/8 x 19-5/8 x 42-1/2
	mm	1145 x 500 x 1080
Net/Gross Weight	lbs	212/245
	kg	96.1/111

EFFICIENCY			
Cooling		Heating	
SEER2	19.4	HSPF2-4	10.4
EER2	12.0	COP	3.8
PERFORMANCE of Cooling			
Cooling (Btu/hr)			
Rated Capacity	36000		
Min/Max Capacity	9000~42000		
Moisture Removal	2		
Standard Operating Range	-22°F~122°F (-30°C~50°C)		
Rated Cooling Conditions:		Indoor: 80°F DB/67°F WB Outdoor: 95°F DB/75°F WB	
PERFORMANCE of Heating			
Heating (Btu/hr)			
1. @ 47°F Rated (Min/Max)	36000(10000~45000)		
2. @ 17°F Rated	33000		
3. @ 5°F Max: Capacity / COP	38000/2		
Standard Operating Range	-22°F~75°F (-30°C~24°C)		
1. Rated Heating Conditions:		Indoor: 70°F DB/60°F WB Outdoor: 47°F DB/43°F WB	
2. Rated Heating Conditions:		Indoor: 70°F DB/60°F WB Outdoor: 17°F DB/15°F WB	
3. Heating Conditions, Compressor Operating at Max. Frequency		Indoor: 70°F DB/60°F WB Outdoor: 5°F DB/5°F WB	

ELECTRICAL	
Power Supply	208/230V,60Hz,1Ph
System MCA	37
Connection Wiring	AWG 14-4
System MOCP	40
Compressor RLA	20.5
Outdoor Fan Motor RLA	2.6
Outdoor Fan Motor W	250
Indoor Fan Motor RLA	/
Indoor Fan Motor W	/
System Power Input @ Cooling (W)	3000/(600 ~ 4200)
System Power Input @ Heating (W)	2776/(600 ~3650)
MCA: Min. circuit amps (A)	MOCP: Max. over current protection (A)
RLA: Rated load amps (A)	W: Fan motor rated output (W)

PIPING	
Liquid Size	5x1/4in (5x6.35mm)
Gas Size	3x3/8in+2x1/2in (3x9.52mm+2x12.7mm)
Drain Size	5/8in (15.88mm)
Max. Piping Length for all rooms	262.4ft (80m)
Max. Piping Length for one IDU	114.8ft (35m)
Max. Height Difference of IDU and ODU	49.2ft (15m)
Refrigerant Pre-charged Amount	134.04oz (3800g)
Refrigerant Precharge Length	24.6ft (7.5m)x5
Additional Charge of Refrigerant (Φ6.35 (1/4") liquid pipe)	0.16oz/ft (15g/m)
Additional Charge of Refrigerant (Φ9.52 (3/8") liquid pipe)	0.32oz/ft(30g/m)
Connection Method	Flared

Outdoor Unit Dimension

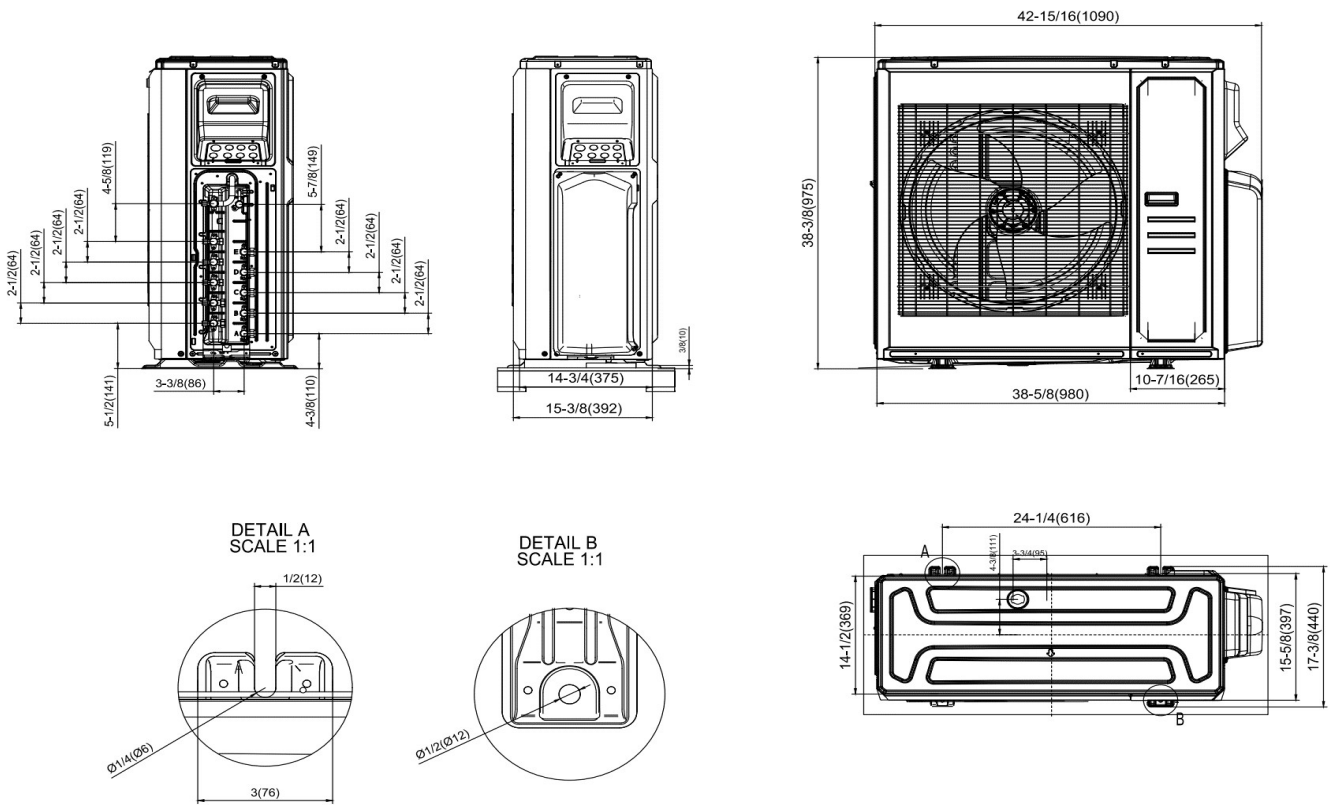

Installation Instruction

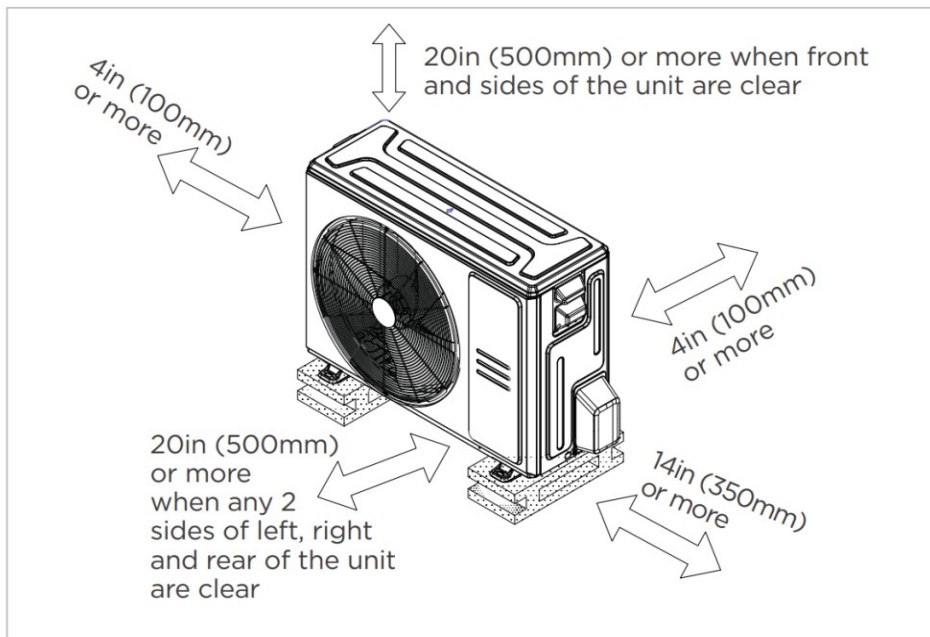

Meets all special requirements shown in Installation Clearance Requirements above.