

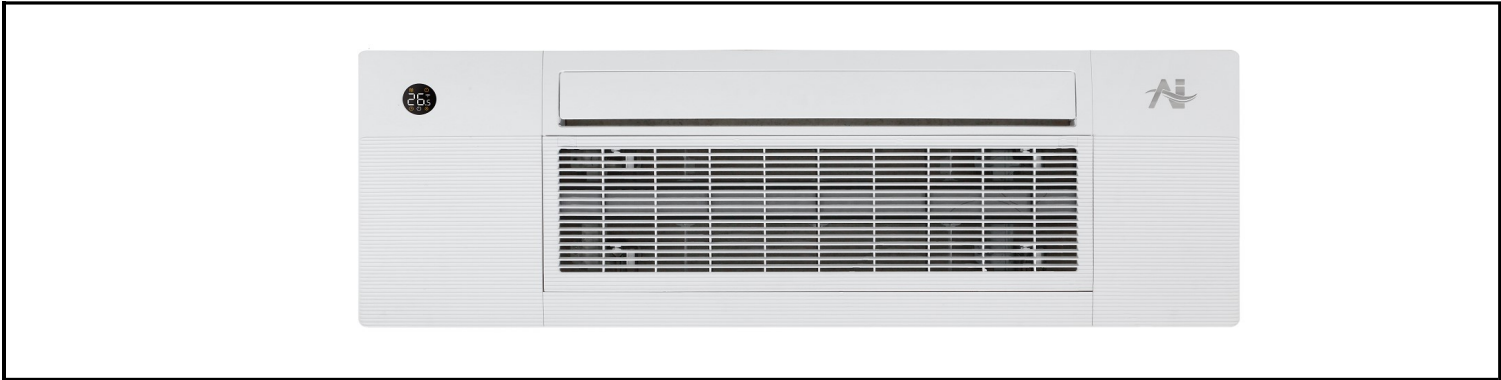

Model Number: A1C-12N2-M1

Location: _____
 Engineer: _____
 Submitted to: _____
 Submitted by: _____
 Reference: _____

Approval: _____
 Date: _____
 Construction: _____
 Unit #: _____
 Drawing #: _____



Item	Unit	Specification
Performance Data		
Cooling Capacity	Btu/h	12000(4000~13900)
Heating Capacity	Btu/h	12500(4600~15200)
Design Pressure	PSIG	550/340
Refrigerant Type	-	R454B
Liquid Side	inch(mm)	1/4in (6.35mm)
Gas Side	inch(mm)	3/8in (9.52mm)
Indoor Operation Range of Cooling	Deg.°F (°C)	60°F~90°F (16°C~32°C)
Indoor Operation Range of Heating	Deg.°F (°C)	32°F~86°F (0°C~30°C)
Electrical		
Normal Operational Voltage	V, Hz, Ph	208/230V,60Hz,1Ph
Voltage Range	V	187-253
Connection Wiring	-	AWG 14-4
Indoor Fan Motor Model	-	ZKFN-30-8-43
Indoor Fan Motor Output	W	30
Indoor Fan Motor RLA	A	1.0
Indoor Fan Motor Speed(Hi/Mi/Lo)	r/min	1075/982/797
Air Flow & Noise Level		
Indoor Air Flow (Turbo/Hi/Mi/Lo/Si)	CFM	353/312/283/247/177
Indoor Noise Level (Turbo/Hi/Mi/Lo/Si)	dB(A)	41/41/37/33/24
Moisture Removal	L/H (pint/H)	1.69L/H (3.57pint/H)
Dimension (W×D×H)	inch	50-3/8 x 13-1/4 x 9
	mm	1278 x 335 x 228
Package (W×D×H)	inch	57-5/8 x 22-1/2 x 22-5/8
	mm	1463 x 571 x 575
Net Weight / Gross Weight	lbs	45/82
	kg	20.5/37.4

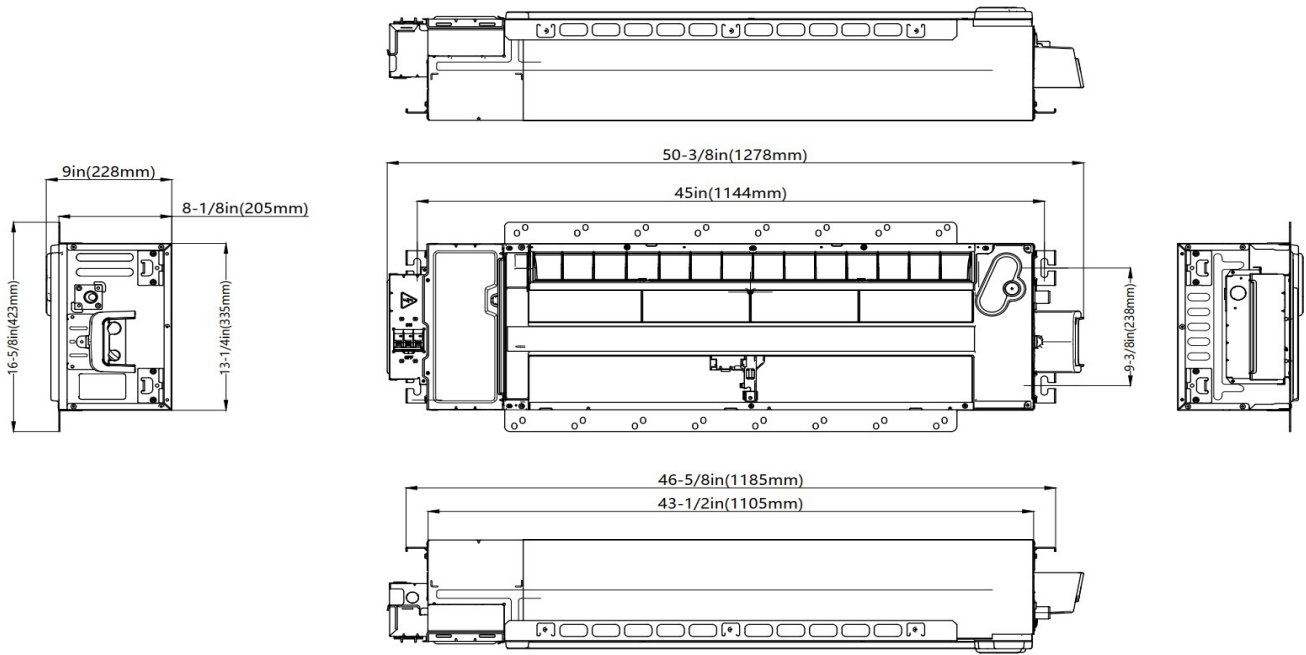

Installation place

(unit: inch/mm)

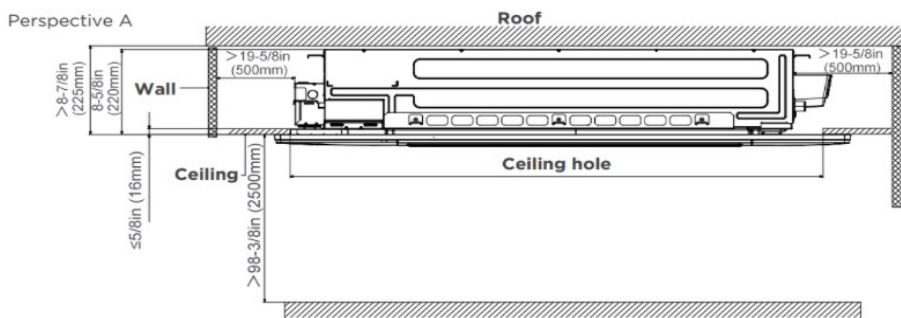

Perspective B

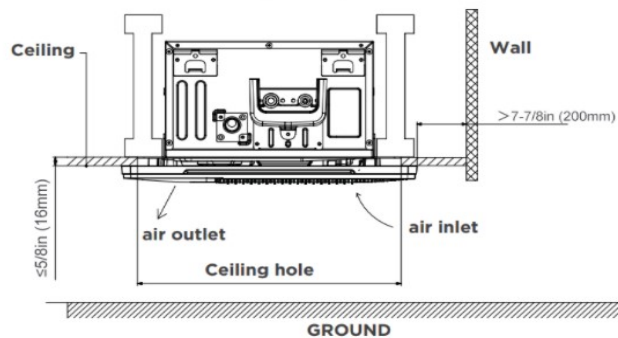

FEATURES

- Designed to fit for both I-joist spacing and traditional joist spacing
- Elevated panel
- Refrigerant leakage detector(Optional)
- Humidity sensor
- Built-in water pump
- Built-in circuit breaker
- 1~100% stepless adjustable fan speed setting
- WiFi capability: through WiFi module or wired controller with WiFi function
- OTA function: can upgrade the program version anytime
- 2-pin connector(HA/HB) for programmable wired controller
- Multiple controller options available:
 - Optional two way communication wired controller, programmable:120N(X6)
 - Optional two way communication wired controller, programmable, with built-in WiFi, :120N(X6W)
 - Optional Infrared wired controller: 120L
 - Standard Wireless remote controller
 - Optional 24V interface kit, can connect with Third-Party 24V Thermostat