

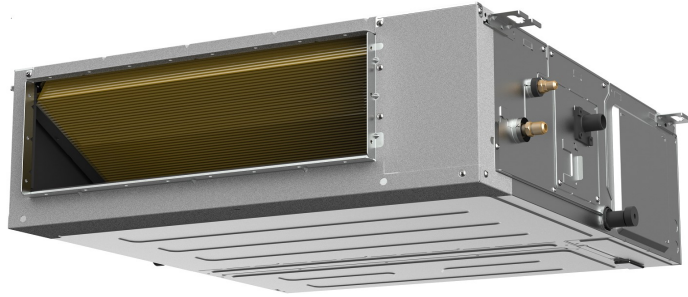

Model Number: AH-12N2-M1

Location: _____
 Engineer: _____
 Submitted to: _____
 Submitted by: _____
 Reference: _____

Approval: _____
 Date: _____
 Construction: _____
 Unit #: _____
 Drawing #: _____



Item	Unit	Specification
Performance Data		
Cooling Capacity	Btu/h	12000(3000~13300)
Heating Capacity	Btu/h	12000(3900~16500)
Design Pressure	PSIG	550/340
Refrigerant Type	-	R454B
Liquid Side	inch(mm)	1/4in (6.35mm)
Gas Side	inch(mm)	3/8in (9.52mm)
Indoor Operation Range of Cooling	Deg.°F (°C)	60°F~90°F (16°C~32°C)
Indoor Operation Range of Heating	Deg.°F (°C)	32°F~86°F (0°C~30°C)
Electrical		
Normal Operational Voltage	V, Hz, Ph	208/230V,60Hz,1Ph
Voltage Range	V	187-253
Connection Wiring	-	AWG 14-4
Indoor Fan Motor Model	-	ZKFN-165-10-1L
Indoor Fan Motor Output	W	165
Indoor Fan Motor RLA	A	1.5
Indoor Fan Motor Speed(Hi/Mi/Lo)	r/min	780/744/708
Air Flow & Noise Level		
Indoor Air Flow (Turbo/Hi/Mi/Lo/Si)	CFM	419/350/265/216/135
Indoor Noise Level (Turbo/Hi/Mi/Lo/Si)	dB(A)	33/33/31/29/26
Moisture Removal	L/H (pint/H)	1.39L/H (2.93pint/H)
Dimension (W×D×H)	inch	27-1/2 x 29-1/2 x 9-5/8
	mm	700 x 750 x 245
Package (W×D×H)	inch	36-3/8 x 33-1/2 x 11-3/4
	mm	925 x 850 x 298
Net Weight / Gross Weight	lbs	64/74
	kg	29.1/33.5

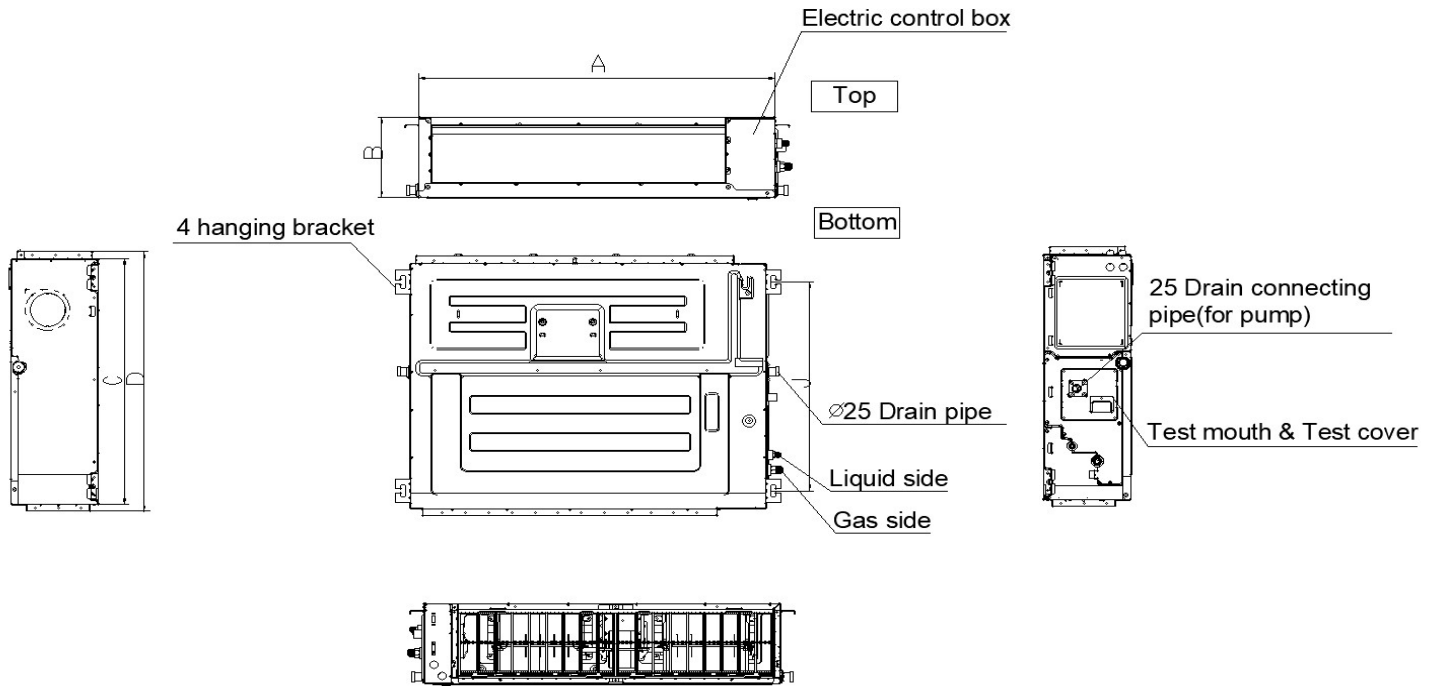

MODEL	A	B	C	D
9K	27-1/2in(700mm)	7-7/8in(200mm)	17-3/4(450mm)	20in(506mm)
12K	27-1/2in(700mm)	9-5/8in(245mm)	29-1/2(750mm)	31-1/4in(795mm)
18K~24K	39-3/8in(1000mm)	9-5/8in(245mm)	29-1/2(750mm)	31-1/4in(795mm)
36K~48K	47-1/8in(1200mm)	11-7/8in(300mm)	29-1/2(750mm)	31-1/4in(795mm)
60K	55-1/8in(1400mm)	15in(380mm)	31-1/2in(800mm)	33-1/4in(845mm)

Installation Instruction

Installation place

The distance between the mounted indoor unit should meet the specifications illustrated in the following diagram.

1) Ceiling-mounted

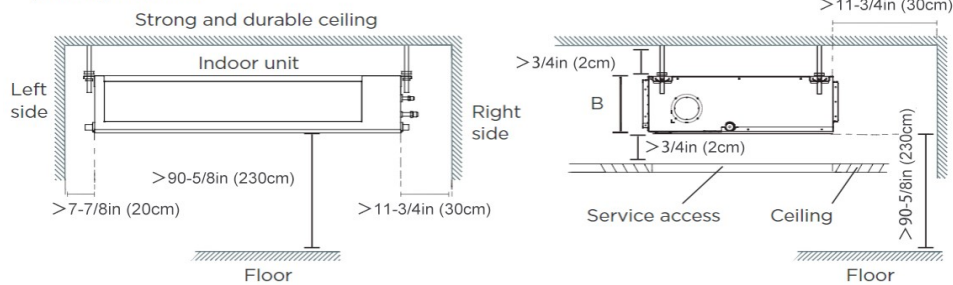

2) Wall-mounted

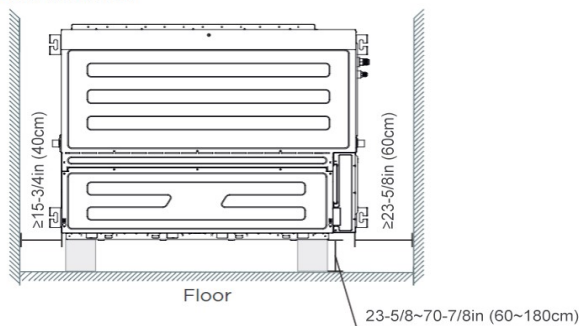

FEATURES

- Compatible with both horizontal and vertical installation
- Static pressure up to 0.8 in.w.g(for all models)
- Static pressure with 8 levels to select
- Refrigerant leakage detector
- Constant airflow
- Built-in water pump
- i-clean function (AI self cleaning)
- 1~100% stepless adjustable fan speed setting
- WiFi capability: through WiFi module or wired controller with WiFi function
- OTA function: can upgrade the program version via wired controller 120N(X6W)
- 2-pin connector(HA/HB) for programmable wired controller
- Multiple controller options available:
 - Optional two way communication wired controller, programmable:120N(X6)
 - Optional two way communication wired controller, programmable, with built-in WiFi, :120N(X6W)
 - Optional Infrared wired controller: 120L
 - Optional Wireless remote controller
 - Optional 24V interface kit, can connect with Third-Party 24V Thermostat