



Model Number: AUO18-60N2-M3 / AUA-60N2-D28

Location: \_\_\_\_\_  
 Engineer: \_\_\_\_\_  
 Submitted to: \_\_\_\_\_  
 Submitted by: \_\_\_\_\_  
 Reference: \_\_\_\_\_

Approval: \_\_\_\_\_  
 Date: \_\_\_\_\_  
 Construction: \_\_\_\_\_  
 Unit #: \_\_\_\_\_  
 Drawing #: \_\_\_\_\_



INDOOR SPECIFICATION		
Dimension (W×D×H)	inch	24-1/2 x 21 x 28
	mm	622 x 533 x 711
Package (W×D×H)	inch	27-3/4 x 26-1/8 x 30-3/8
	mm	705 x 665 x 770
Net/Gross Weight	lbs	81 / 92
	kg	36.8 / 41.9

OUTDOOR SPECIFICATION		
Compressor Type		ROTARY
Refrigerant		R454B
Factory Charge		1800ml
Refrigerant Oil		HAF68D1C
Outdoor Air Flow (Max) (CFM)		3,037
Outdoor Noise Level (dBA)		65
Dimension (W×D×H)	inch	38-5/8 x 16-3/8 x 38-3/8
	mm	980 x 415 x 975
Package (W×D×H)	inch	45-1/8 x 19-5/8 x 42-1/2
	mm	1145 x 500 x 1080
Net/Gross Weight	lbs	193 / 224
	kg	87.5 / 101.7

EFFICIENCY			
Cooling		Heating	
SEER2	14.3	HSPF2-4	7.3
EER2	8.1	COP	2.7

PERFORMANCE of Cooling	
Cooling (Btu/hr)	
Rated Capacity	50,000
Min/Max Capacity	15,500~50,000
Moisture Removal	4
Standard Operating Range	-13°F~122°F (-25°C~50°C)
Rated Cooling Conditions:	Indoor: 80°F DB/67°F WB Outdoor: 95°F DB/75°F WB

PERFORMANCE of Heating	
Heating (Btu/hr)	
1. @ 47°F Rated (Min/Max)	48,000(10,600~50,000)
2. @ 17°F Rated	29,000
3. @ 5°F Max: Capacity / COP	42,000/1.75
Standard Operating Range	-22°F~75°F (-30°C~24°C)
1. Rated Heating Conditions:	Indoor: 70°F DB/60°F WB Outdoor: 47°F DB/43°F WB
2. Rated Heating Conditions:	Indoor: 70°F DB/60°F WB Outdoor: 17°F DB/15°F WB
3. Heating Conditions, Compressor Operating at Max. Frequency	Indoor: 70°F DB/60°F WB Outdoor: 5°F DB/5°F WB

ELECTRICAL	
Indoor Power Supply	24V,60Hz,1Ph
Indoor MCA 115V/(208/230V)	/
Indoor MOP	/
Outdoor Power Supply	208/230,60Hz,1Ph
Outdoor MCA	39.0
Outdoor MOP	40.0
Communication Wiring	AWG 20/2
Compressor RLA	30.0
Outdoor Fan Motor RLA	1.2
Outdoor Fan Motor W	250.0
Indoor Fan Motor RLA	/
Indoor Fan Motor W	/
System Power Input @ Cooling (W)	6,100 ( 1,430 ~ 6,150)
System Power Input @ Heating (W)	5,190 ( 1,210 ~ 5,190)
MCA: Min. circuit amps (A)	MOCP: Max. over current protection (A)
RLA: Rated load amps (A)	W: Fan motor rated output (W)

PIPING	
Liquid Size	3/8in (9.52mm)
Gas Size	3/4in (19mm)
Drain Size	5/8in (15.88mm)
Max. Piping Length	246ft (75m)
Max. Height Difference	98.4ft (30m)
Max. Pre-charged Length	24.6ft (7.5m)
Refrigerant Pre-charged Amount	134oz (3800g)
Additional Charge of Refrigerant	0.7oz/ft (65g/m)
Connection Method	Flared

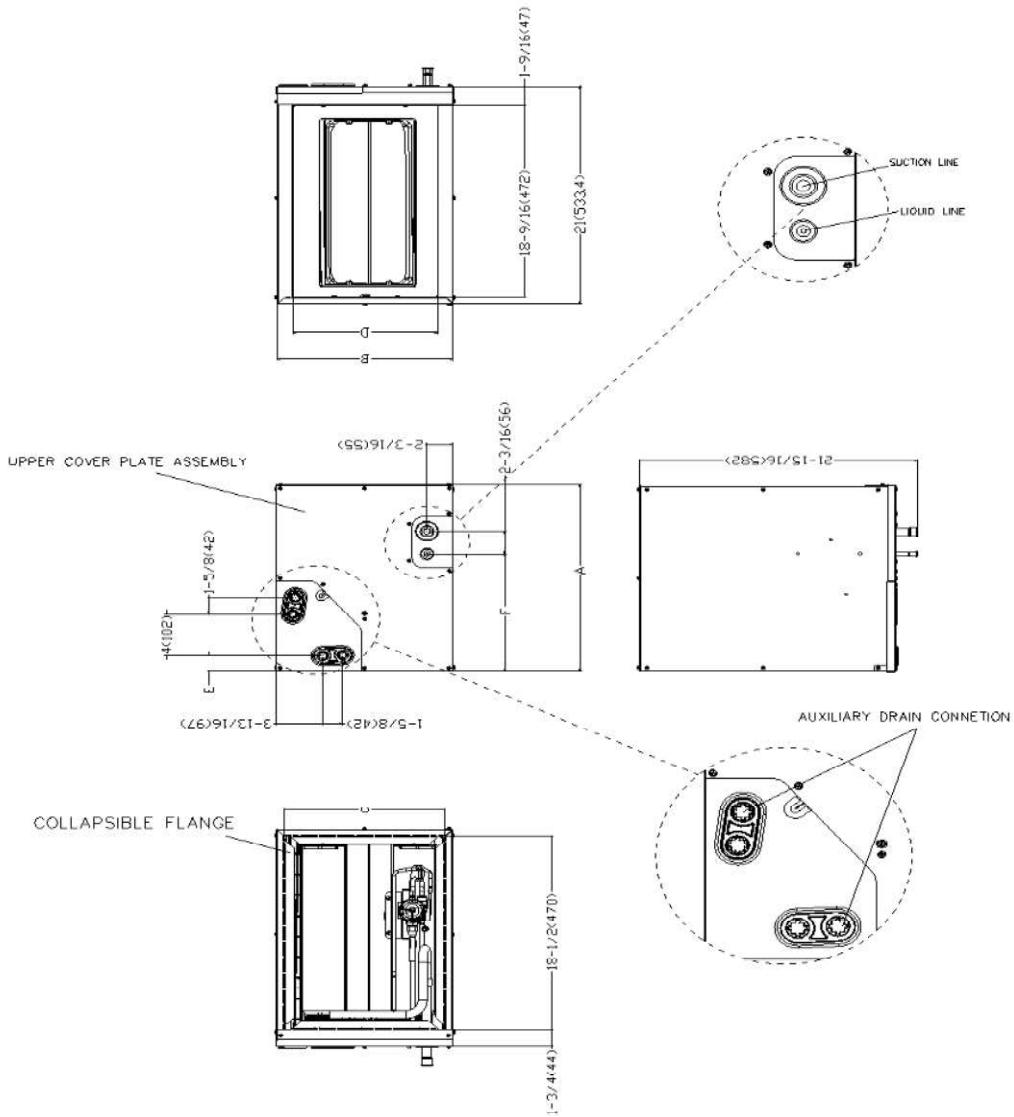

Model		60-D	
Dimensions		inch	mm
A	Model Height	28	711
B	Model Width	24-1/2	622
C	Supply Air Opening Width	23-1/4	591
D	Return Air Opening Width	23-1/8	587
E	Condensate Drains Height	2-3/16	55
F	Liquid Line Height	21-7/16	545

## Outdoor Unit Dimension

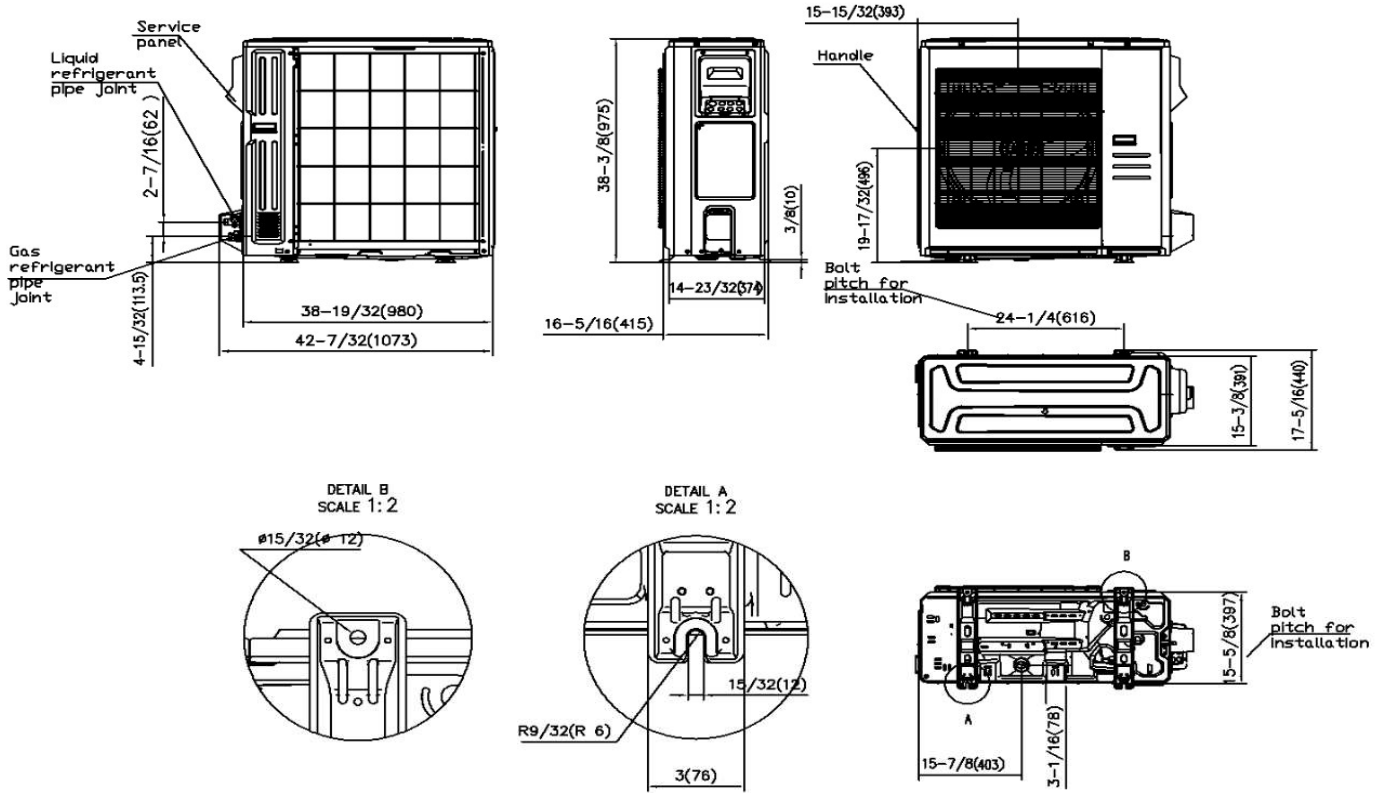

## Installation Instruction



Meets all special requirements shown in Installation Clearance Requirements above.

- Multi-position installation: horizontal(left or right), vertical( up or down)
- Aluminum Coil
- R454B refrigerant sensor
- Easy Maintenance
- Multiple control options available:
  - Two way communication wired controller with built-in WiFi:120N(X6W)
  - Third-Party 24V Thermostat