



Model Number: AUO18-36N2-M3 / AUA-36N2-A24

Location: _____
 Engineer: _____
 Submitted to: _____
 Submitted by: _____
 Reference: _____

Approval: _____
 Date: _____
 Construction: _____
 Unit #: _____
 Drawing #: _____



| INDOOR SPECIFICATION | | |
|----------------------|------|----------------------|
| Dimension (W×D×H) | inch | 14-1/2 x 21 x 23-1/4 |
| | mm | 368 x 533 x 592 |
| Package (W×D×H) | inch | 17-1/2 x 25-3/8 x 26 |
| | mm | 445 x 645 x 660 |
| Net/Gross Weight | lbs | 57 / 65 |
| | kg | 25.8 / 29.4 |

| OUTDOOR SPECIFICATION | | |
|------------------------------|--------|--------------------------|
| Compressor Type | ROTARY | |
| Refrigerant | R454B | |
| Factory Charge | 1000ml | |
| Refrigerant Oil | VG74 | |
| Outdoor Air Flow (Max) (CFM) | 2,413 | |
| Outdoor Noise Level (dBA) | 63 | |
| Dimension (W×D×H) | inch | 37-1/4 x 16-1/8 x 31-7/8 |
| | mm | 946 x 410 x 810 |
| Package (W×D×H) | inch | 42-7/8 x 19-5/8 x 34-7/8 |
| | mm | 1090 x 500 x 885 |
| Net/Gross Weight | lbs | 153 / 164 |
| | kg | 69.5 / 74.2 |

| EFFICIENCY | | | |
|------------|------|---------|-----|
| Cooling | | Heating | |
| SEER2 | 14.3 | HSPF2-4 | 8.5 |
| EER2 | 9.0 | COP | 3.0 |

| PERFORMANCE of Cooling | |
|---------------------------|---|
| Cooling (Btu/hr) | |
| Rated Capacity | 34,000 |
| Min/Max Capacity | 10,400~35,000 |
| Moisture Removal | 4 |
| Standard Operating Range | -13°F~122°F (-25°C~50°C) |
| Rated Cooling Conditions: | Indoor: 80°F DB/67°F WB Outdoor: 95°F DB/75°F WB |

| PERFORMANCE of Heating | |
|---|---|
| Heating (Btu/hr) | |
| 1. @ 47°F Rated (Min/Max) | 36,000(11,200~39,400) |
| 2. @ 17°F Rated | 24,800 |
| 3. @ 5°F Max: Capacity / COP | 27,200/1.83 |
| Standard Operating Range | -13°F~75°F (-25°C~24°C) |
| 1. Rated Heating Conditions: | Indoor: 70°F DB/60°F WB Outdoor: 47°F DB/43°F WB |
| 2. Rated Heating Conditions: | Indoor: 70°F DB/60°F WB Outdoor: 17°F DB/15°F WB |
| 3. Heating Conditions, Compressor Operating at Max. Frequency | Indoor: 70°F DB/60°F WB Outdoor: 5°F DB/5°F WB |

| ELECTRICAL | |
|----------------------------------|--|
| Indoor Power Supply | 24V,60Hz,1Ph |
| Indoor MCA 115V/(208/230V) | / |
| Indoor MOP | / |
| Outdoor Power Supply | 208/230,60Hz,1Ph |
| Outdoor MCA | 24.0 |
| Outdoor MOP | 30.0 |
| Communication Wiring | AWG 20/2 |
| Compressor RLA | 17.5 |
| Outdoor Fan Motor RLA | 1.5 |
| Outdoor Fan Motor W | 120.0 |
| Indoor Fan Motor RLA | / |
| Indoor Fan Motor W | / |
| System Power Input @ Cooling (W) | 3,780 (480 ~ 3,600) |
| System Power Input @ Heating (W) | 3,517 (550 ~ 3,240) |
| MCA: Min. circuit amps (A) | MOCP: Max. over current protection (A) |
| RLA: Rated load amps (A) | W: Fan motor rated output (W) |

| PIPING | |
|----------------------------------|------------------|
| Liquid Size | 3/8in (9.52mm) |
| Gas Size | 3/4iin (19mm) |
| Drain Size | 5/8in (15.88mm) |
| Max. Piping Length | 246ft (75m) |
| Max. Height Difference | 98.4ft (30m) |
| Max. Pre-charged Length | 24.6ft (7.5m) |
| Refrigerant Pre-charged Amount | 116oz (3300g) |
| Additional Charge of Refrigerant | 0.7oz/ft (65g/m) |
| Connection Method | Flared |

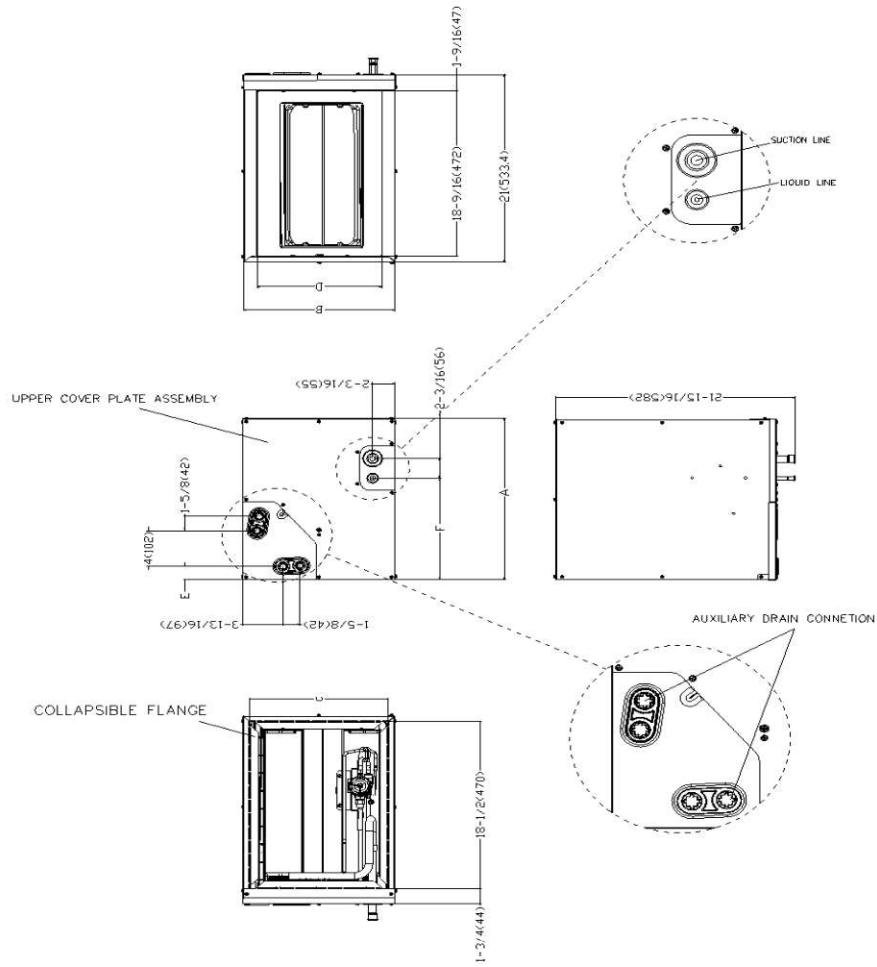

| Dimensions | | Model(Btu/h) | | 24-A | | 36-A | | 36-B | |
|------------|--------------------------|--------------|-----|----------|-----|----------|-----|------|--|
| | | inch | mm | inch | mm | inch | mm | | |
| A | Model Height | 18 | 457 | 23-5/16 | 592 | 23-1/2 | 599 | | |
| B | Model Width | 14-1/2 | 368 | 14-1/2 | 368 | 17-1/2 | 445 | | |
| C | Supply Air Opening Width | 13-1/4 | 336 | 13-1/4 | 336 | 16-3/16 | 411 | | |
| D | Return Air Opening Width | 11-15/16 | 303 | 11-15/16 | 303 | 14-15/16 | 380 | | |
| E | Condensate Drains Height | 1-7/16 | 38 | 1-7/16 | 38 | 1-7/16 | 38 | | |
| F | Liquid Line Height | 11-3/8 | 290 | 17-15/16 | 455 | 16-3/8 | 417 | | |
| Dimensions | | Model(Btu/h) | | 24-B | | 36-C | | | |
| | | inch | mm | inch | mm | | | | |
| A | Model Height | 18 | 457 | 24 | 611 | | | | |
| B | Model Width | 17-1/2 | 445 | 21 | 534 | | | | |
| C | Supply Air Opening Width | 16-3/16 | 411 | 19-3/4 | 502 | | | | |
| D | Return Air Opening Width | 14-15/16 | 380 | 18-7/16 | 468 | | | | |
| E | Condensate Drains Height | 1-7/16 | 38 | 2-3/16 | 55 | | | | |
| F | Liquid Line Height | 11-3/8 | 290 | 17-1/2 | 445 | | | | |

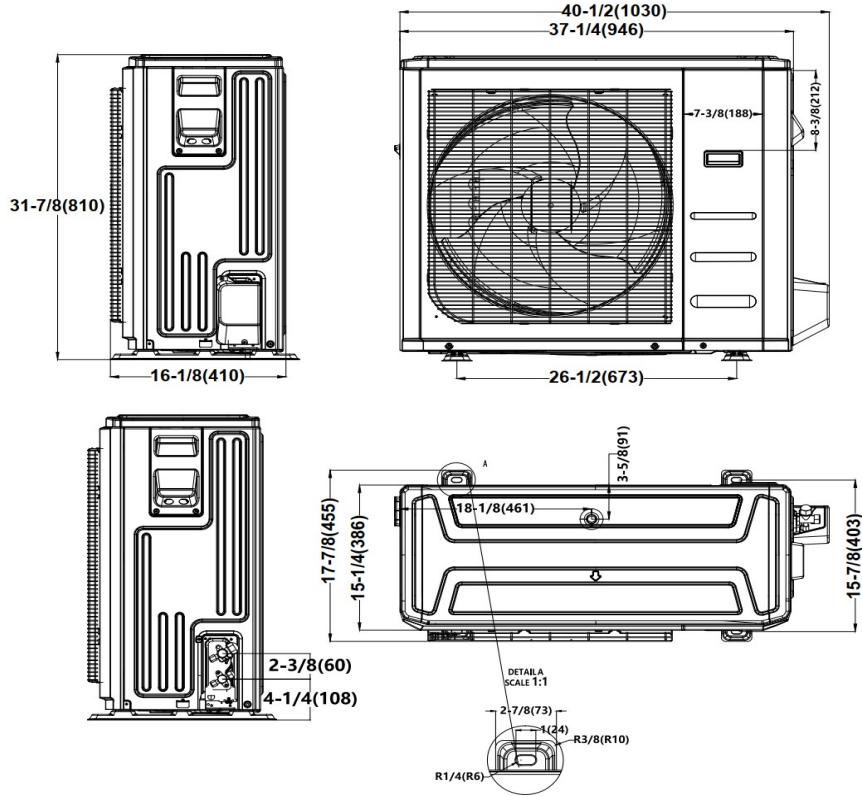

Installation Instruction



☑ Meets all special requirements shown in Installation Clearance Requirements above.

- Multi-position installation: horizontal(left or right), vertical(up or down)
- Aluminum Coil
- R454B refrigerant sensor
- Easy Maintenance
- Multiple control options available:
 - Two way communication wired controller with built-in WiFi:120N(X6W)
 - Third-Party 24V Thermostat