



Location: \_\_\_\_\_  
 Engineer: \_\_\_\_\_  
 Submitted to: \_\_\_\_\_  
 Submitted by: \_\_\_\_\_  
 Reference: \_\_\_\_\_

Model Number: AUO18-60N2-M3 / AUH2-60N2-DM3E

Approval: \_\_\_\_\_  
 Date: \_\_\_\_\_  
 Construction: \_\_\_\_\_  
 Unit #: \_\_\_\_\_  
 Drawing #: \_\_\_\_\_



INDOOR SPECIFICATION		
Indoor Air Flow (Turbo/H/M/L/S) (CFM)	1807/1583/1360/1136/1136	
Indoor Noise Level (T/H/M/L/S) (dBA)	56/52/49/35/35	
Dimension (W×D×H)	inch	21 x 24-1/2 x 53
	mm	534 x 622 x 1346
Package (W×D×H)	inch	28 x 26-3/4 x 56-1/2
	mm	710 x 680 x 1435
Net/Gross Weight	lbs	163/191
	kg	73.9/86.6

OUTDOOR SPECIFICATION		
Compressor Type	ROTARY	
Refrigerant	R454B	
Factory Charge	1800ml	
Refrigerant Oil	HAF68D1C	
Outdoor Air Flow (Max) (CFM)	3037.1	
Outdoor Noise Level (dBA)	65.0	
Dimension (W×D×H)	inch	38-5/8 x 16-3/8 x 38-3/8
	mm	980 x 415 x 975
Package (W×D×H)	inch	45-1/8 x 19-5/8 x 42-1/2
	mm	1145 x 500 x 1080
Net/Gross Weight	lbs	193/224
	kg	87.5/101.7

EFFICIENCY			
Cooling		Heating	
SEER2	15.2	HSPF2-4	8.4
EER2	8.6	COP	3.4

PERFORMANCE of Cooling	
Cooling (Btu/hr)	
Rated Capacity	54000
Min/Max Capacity	21000~55000
Moisture Removal	5.82
Standard Operating Range	-13°F~-122°F (-25°C~50°C)
Rated Cooling Conditions:	Indoor: 80°F DB/67°F WB Outdoor: 95°F DB/75°F WB

PERFORMANCE of Heating	
Heating (Btu/hr)	
1. @ 47°F Rated (Min/Max)	54000(26000~55000)
2. @ 17°F Rated	33000
3. @ 5°F Max: Capacity / COP	38000/1.8
Standard Operating Range	-13°F ~75°F (-25°C~24°C)
1. Rated Heating Conditions:	Indoor: 70°F DB/60°F WB Outdoor: 47°F DB/43°F WB
2. Rated Heating Conditions:	Indoor: 70°F DB/60°F WB Outdoor: 17°F DB/15°F WB
3. Heating Conditions, Compressor Operating at Max. Frequency	Indoor: 70°F DB/60°F WB Outdoor: 5°F DB/5°F WB

ELECTRICAL	
Indoor Power Supply	115/208/230V, 60Hz, 1Ph
Indoor MCA 115V/(208/230V)	14.5/11.0
Indoor MOP	15
Outdoor Power Supply	208/230V, 60Hz, 1Ph
Outdoor MCA	39
Outdoor MOP	40
Communication Wiring	AWG 20-2
Compressor RLA	30
Outdoor Fan Motor RLA	1.2
Outdoor Fan Motor W	250
Indoor Fan Motor RLA	8.3
Indoor Fan Motor W	750
System Power Input @ Cooling (W)	6200(1800 ~ 6410)
System Power Input @ Heating (W)	4650(975 ~4810)
MCA: Min. circuit amps (A)	MOCP: Max. over current protection (A)
RLA: Rated load amps (A)	W: Fan motor rated output (W)

PIPING	
Liquid Size	3/8in (9.52mm)
Gas Size	3/4in (19mm)
Drain Size	5/8in (15.88mm)
Max. Piping Length	246ft (75m)
Max. Height Difference	98.4ft (30m)
Max. Pre-charge Length	24.6ft (7.5m)
Refrigerant Pre-charged Amount	134.04oz (3800g)
Additional Charge of Refrigerant	0.7oz/ft (65g/m)
Connection Method	Flared

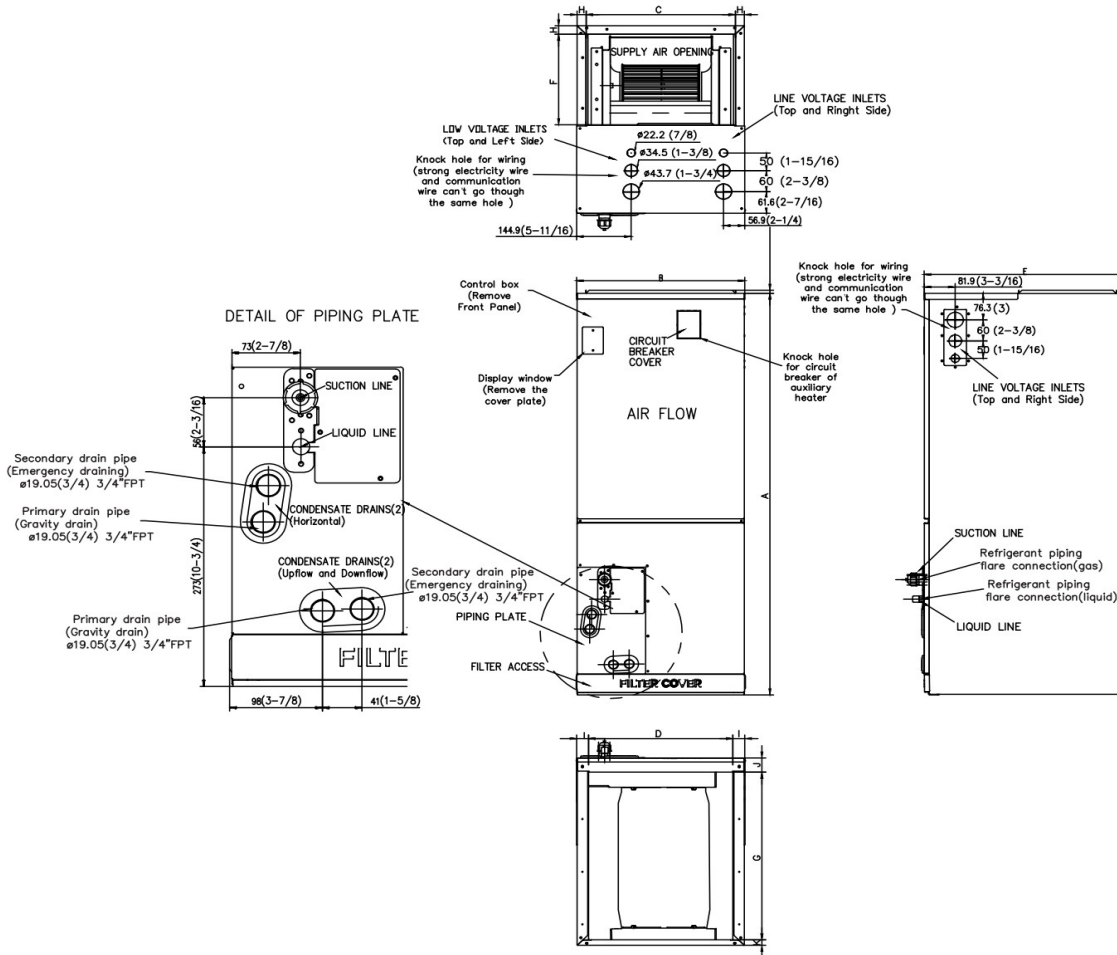

Dimensions	Model	18k/24k		30k/36k		48k/60k	
		inch	mm	inch	mm	inch	mm
A	Model Height	45	1143	49	1245	53	1346
B	Model Width	17-1/2	445	21	534	24-1/2	622
C	Supply Air Opening Width	15-5/8	397	19-1/8	486	22-5/8	575
D	Return Air Opening Width	15-1/8	384	18-5/8	473	22-1/8	562
E	Model Depth	21	534	21	534	21	534
F	Supply Air Opening Depth	10-1/4	260	10-1/4	260	10-1/4	260
G	Return Air Opening Depth	18-3/4	476	18-3/4	476	18-3/4	476
H	Supply Air Opening Clearance	15/16	24	15/16	24	15/16	24
I	Return Air Opening Side Clearance	1-1/4	32	1-1/4	32	1-1/8	28
J	Return Air Opening Front Clearance	1-1/2	38	1-5/8	41	1-5/8	41
K	Return Air Opening Back Clearance	5/8	16	5/8	16	3/4	19

## Outdoor Unit Dimension

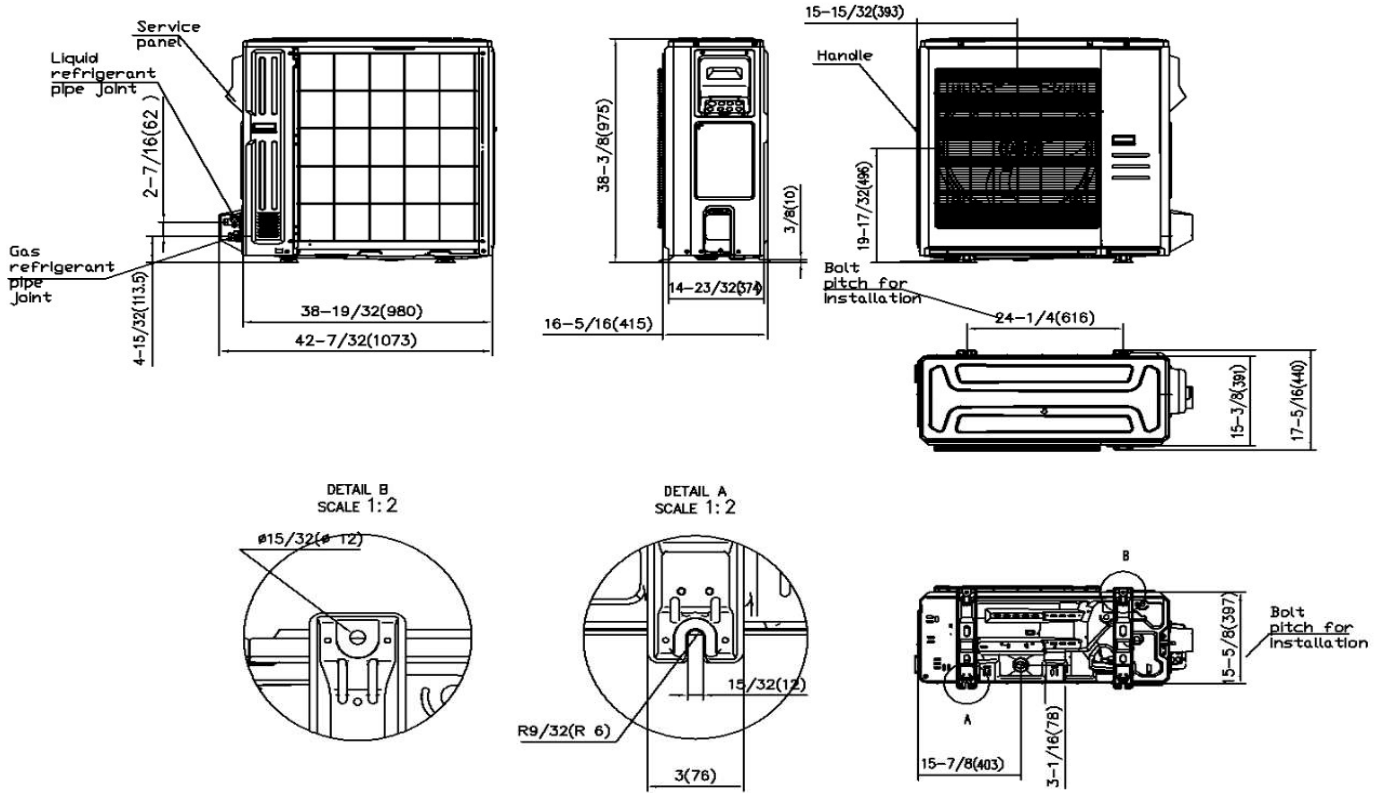

## Installation Instruction

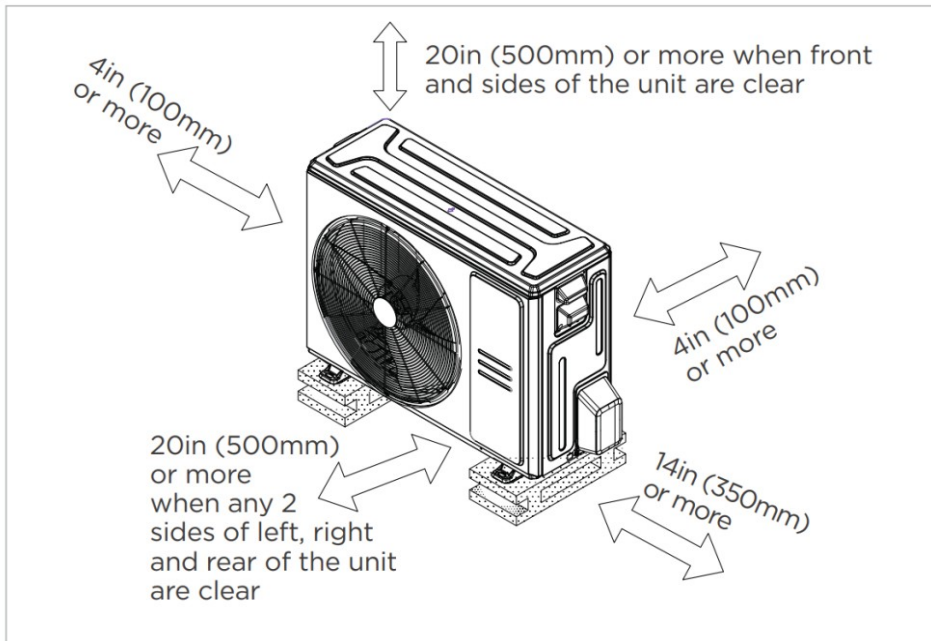

- Meets all special requirements shown in Installation Clearance Requirements above.

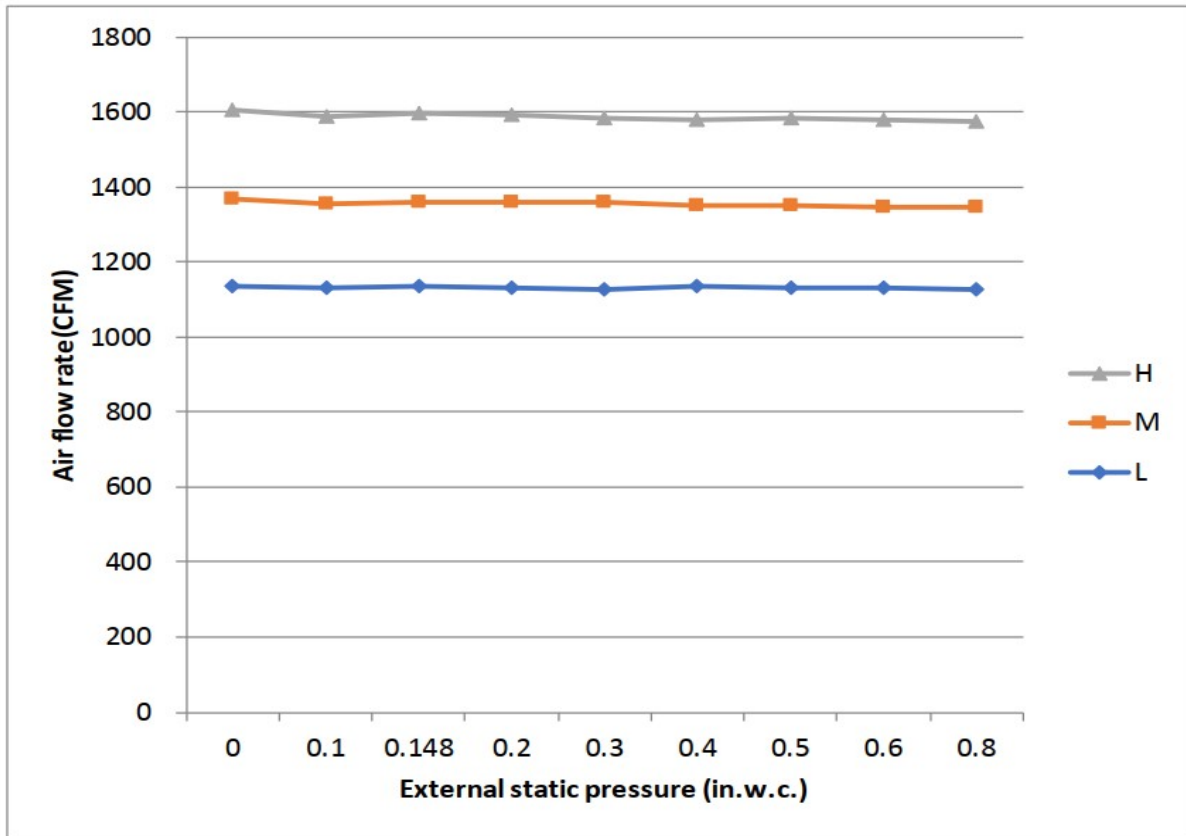

Features

- Multi-position installation: horizontal(left or right), vertical( up or down)
- Aluminum Coil
- Constantly Air Flow system up to 0.80 In.W.G
- 1 inch thick R4.2 fiberglass free insulation, reduce condensation and increase efficiency(optional)
- Optional Auxiliary heat kit up to 25kW
- Easy Maintenance
- Multiple controller options available:
  - Optional two way communication wired controller, programmable:120N(X6)
  - Optional two way communication wired controller, programmable, with built-in WiFi, :120N(X6W)
  - Standard Wireless remote controller
  - Can connect with Third-Party 24V Thermostat
- Adapted to RS485 and 24V communication controllers
- High efficiency up to 18.8 SEER2, 11 EER2, 9.7 HSPF2
- Chassis heater and crankcase heater pre-bulit as standard