

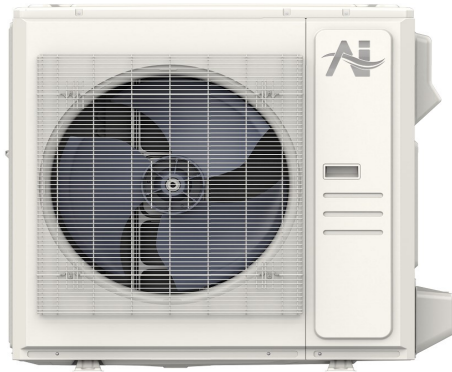

Location: \_\_\_\_\_  
 Engineer: \_\_\_\_\_  
 Submitted to: \_\_\_\_\_  
 Submitted by: \_\_\_\_\_  
 Reference: \_\_\_\_\_

Model Number: AUO19-36N2-M3H-S / AUA-36N2-A24

Approval: \_\_\_\_\_  
 Date: \_\_\_\_\_  
 Construction: \_\_\_\_\_  
 Unit #: \_\_\_\_\_  
 Drawing #: \_\_\_\_\_



INDOOR SPECIFICATION		
Dimension (W×D×H)	inch	14-1/2 x 21 x 23-1/4
	mm	368 x 533 x 592
Package (W×D×H)	inch	17-1/2 x 25-3/8 x 26
	mm	445 x 645 x 660
Net/Gross Weight	lbs	57 / 65
	kg	25.8 / 29.4

OUTDOOR SPECIFICATION		
Compressor Type	TWIN-ROTARY	
Refrigerant	R454B	
Factory Charge	1460ml	
Refrigerant Oil	VG75	
Outdoor Air Flow (Max) (CFM)	3,002	
Outdoor Noise Level (dBA)	64	
Dimension (W×D×H)	inch	38-5/8 x 16-3/8 x 38-3/8
	mm	980 x 415 x 975
Package (W×D×H)	inch	45-1/8 x 19-5/8 x 42-1/2
	mm	1145 x 500 x 1080
Net/Gross Weight	lbs	204 / 235
	kg	92.6 / 106.7

EFFICIENCY			
Cooling		Heating	
SEER2	15.2	HSPF2-4	9.0
EER2	10.2	COP	3.1

PERFORMANCE of Cooling	
Cooling (Btu/hr)	
Rated Capacity	36,000
Min/Max Capacity	11,400~39,000
Moisture Removal	4.3
Standard Operating Range	-22°F~122°F (-30°C~50°C)
Rated Cooling Conditions:	Indoor: 80°F DB/67°F WB Outdoor: 95°F DB/75°F WB

PERFORMANCE of Heating	
Heating (Btu/hr)	
1. @ 47°F Rated (Min/Max)	37,000(11,500~46,000)
2. @ 17°F Rated	29,000
3. @ 5°F Max: Capacity / COP	31,000/1.8
Standard Operating Range	-22°F~75°F (-30°C~24°C)
1. Rated Heating Conditions:	Indoor: 70°F DB/60°F WB Outdoor: 47°F DB/43°F WB
2. Rated Heating Conditions:	Indoor: 70°F DB/60°F WB Outdoor: 17°F DB/15°F WB
3. Heating Conditions, Compressor Operating at Max. Frequency	Indoor: 70°F DB/60°F WB Outdoor: 5°F DB/5°F WB

ELECTRICAL	
Indoor Power Supply	24V,60Hz,1Ph
Indoor MCA 115V/(208/230V)	/
Indoor MOP	/
Outdoor Power Supply	208/230,60Hz,1Ph
Outdoor MCA	29.0
Outdoor MOP	30.0
Communication Wiring	AWG 20/2
Compressor RLA	20.5
Outdoor Fan Motor RLA	2.4
Outdoor Fan Motor W	/
Indoor Fan Motor RLA	/
Indoor Fan Motor W	/
System Power Input @ Cooling (W)	3,530 ( 800 ~ 3,250)
System Power Input @ Heating (W)	3,500 ( 800 ~ 4,540)
MCA: Min. circuit amps (A)	MOCP: Max. over current protection (A)
RLA: Rated load amps (A)	W: Fan motor rated output (W)

PIPING	
Liquid Size	3/8in (9.52mm)
Gas Size	3/4iin (19mm)
Drain Size	5/8in (15.88mm)
Max. Piping Length	246ft (75m)
Max. Height Difference	98.4ft (30m)
Max. Pre-charged Length	24.6ft (7.5m)
Refrigerant Pre-charged Amount	127oz (3600g)
Additional Charge of Refrigerant	0.7oz/ft (65g/m)
Connection Method	Flared

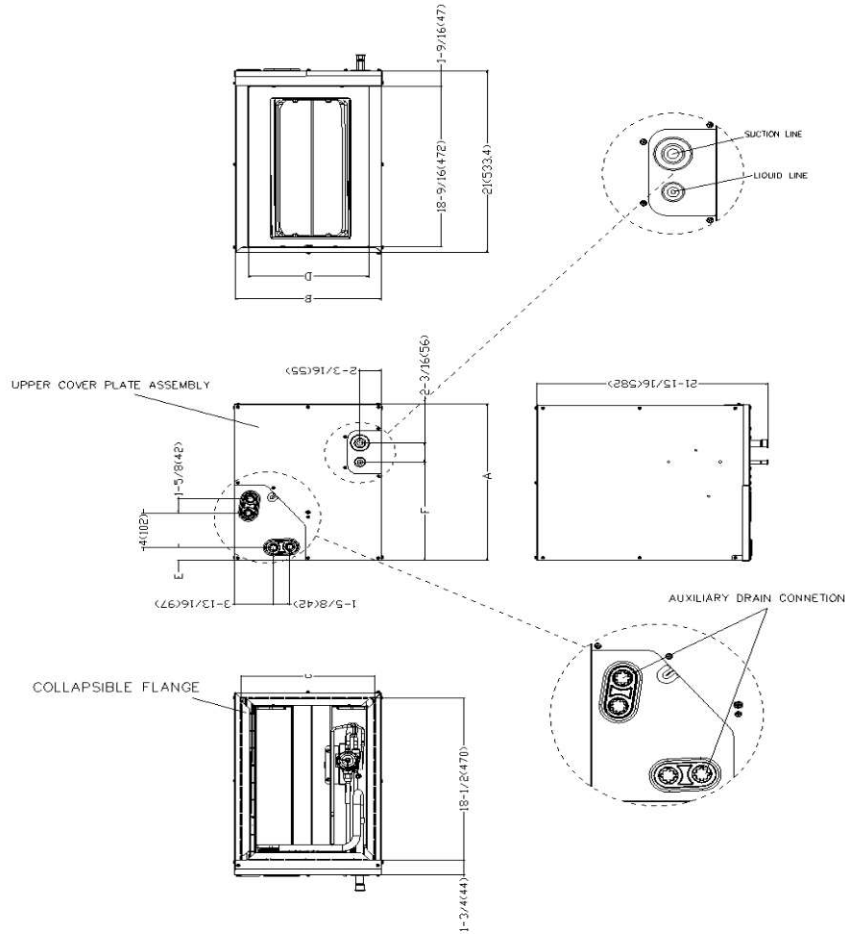

Dimensions		Model(Btu/h)		24-A		36-A		36-B	
		inch	mm	inch	mm	inch	mm		
A	Model Height	18	457	23-5/16	592	23-1/2	599		
B	Model Width	14-1/2	368	14-1/2	368	17-1/2	445		
C	Supply Air Opening Width	13-1/4	336	13-1/4	336	16-3/16	411		
D	Return Air Opening Width	11-15/16	303	11-15/16	303	14-15/16	380		
E	Condensate Drains Height	1-7/16	38	1-7/16	38	1-7/16	38		
F	Liquid Line Height	11-3/8	290	17-15/16	455	16-3/8	417		
Dimensions		Model(Btu/h)		24-B		36-C			
		inch	mm	inch	mm				
A	Model Height	18	457	24	611				
B	Model Width	17-1/2	445	21	534				
C	Supply Air Opening Width	16-3/16	411	19-3/4	502				
D	Return Air Opening Width	14-15/16	380	18-7/16	468				
E	Condensate Drains Height	1-7/16	38	2-3/16	55				
F	Liquid Line Height	11-3/8	290	17-1/2	445				

## Outdoor Unit Dimension

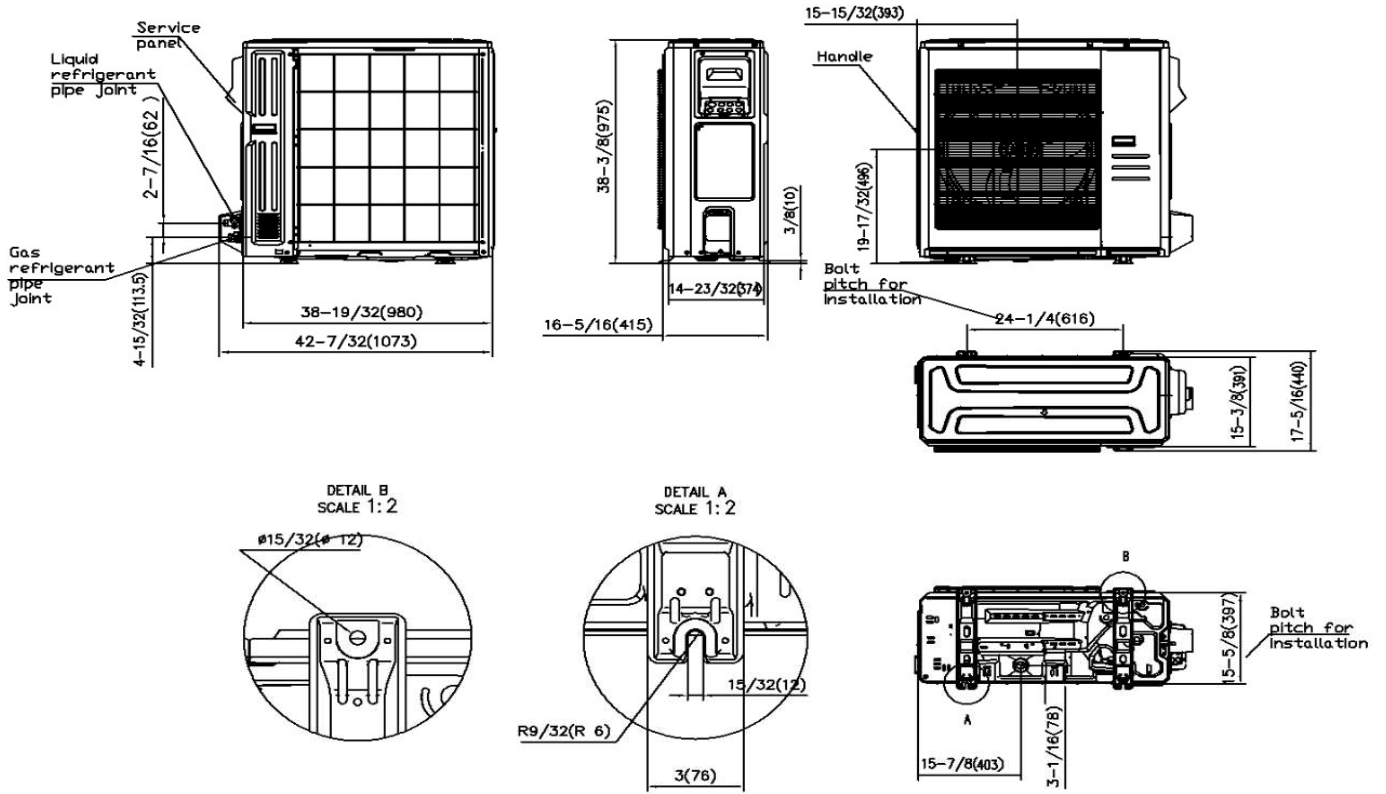

## Installation Instruction



Meets all special requirements shown in Installation Clearance Requirements above.

- Multi-position installation: horizontal(left or right), vertical( up or down)
- Aluminum Coil
- R454B refrigerant sensor
- Easy Maintenance
- Multiple control options available:
  - Two way communication wired controller with built-in WiFi:120N(X6W)
  - Third-Party 24V Thermostat