

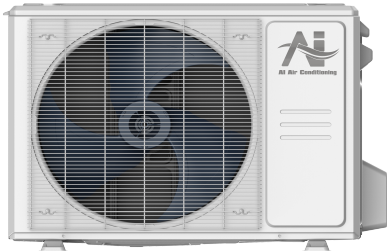

Location: _____
 Engineer: _____
 Submitted to: _____
 Submitted by: _____
 Reference: _____

Model Number: AUO19-24N2-M3H / AUH3-24N2-AM3E

Approval: _____
 Date: _____
 Construction: _____
 Unit #: _____
 Drawing #: _____



INDOOR SPECIFICATION

ESP(inWG)	0~1.0	
Indoor Air Flow (Turbo/H/M/L/S) (CFM)	824/759/695/630/630	
Indoor Noise Level (T/H/M/L/S) (dBA)	48/48/44/33/33	
Dimension (W×D×H)	inch	21-1/2 x 14-1/2 x 49-3/4
	mm	546 x 368 x 1263
Package (W×D×H)	inch	53 x 17-1/2 x 31-1/8
	mm	1345 x 445 x 790
Net/Gross Weight	lbs	123/155
	kg	55.8/70.2

OUTDOOR SPECIFICATION

Compressor Type	ROTARY	
Refrigerant	R454B	
Factory Charge	620ml	
Refrigerant Oil	VG74	
Outdoor Air Flow (Max) (CFM)	1765.7	
Outdoor Noise Level (dBA)	59.0	
Dimension (W×D×H)	inch	35 x 13-1/2 x 26-1/2
	mm	890 x 342 x 673
Package (W×D×H)	inch	39-1/8 x 15-5/8 x 29-1/8
	mm	995 x 398 x 740
Net/Gross Weight	lbs	102/109
	kg	46.4/49.5

EFFICIENCY

Cooling		Heating	
SEER2	18.6	HSPF2-4	10.0
EER2	12.0	COP	3.5

PERFORMANCE of Cooling

Cooling (Btu/hr)

Rated Capacity	24000
Min/Max Capacity	6400~28700
Moisture Removal	2.23
Standard Operating Range	-22°F~122°F (-30°C~50°C)

Rated Cooling Conditions: Indoor: 80°F DB/67°F WB
 Outdoor: 95°F DB/75°F WB

PERFORMANCE of Heating

Heating (Btu/hr)

1. @ 47°F Rated (Min/Max)	24000(6700~29100)
2. @ 17°F Rated	19000
3. @ 5°F Max: Capacity / COP	20600/2.14
Standard Operating Range	-22°F ~75°F (-30°C~24°C)

1. Rated Heating Conditions: Indoor: 70°F DB/60°F WB
 Outdoor: 47°F DB/43°F WB
 2. Rated Heating Conditions: Indoor: 70°F DB/60°F WB
 Outdoor: 17°F DB/15°F WB
 3. Heating Conditions, Compressor Operating at Max. Frequency Indoor: 70°F DB/60°F WB
 Outdoor: 5°F DB/5°F WB

ELECTRICAL

Indoor Power Supply	115/208/230V,60Hz,1Ph	
Indoor MCA 115V/(208/230V)	5.5/3.5	
Indoor MOP	15	
Outdoor Power Supply	208/230V,60Hz,1Ph	
Outdoor MCA	19	
Outdoor MOP	20	
Communication Wiring	AWG 20-2	
Compressor RLA	14	
Outdoor Fan Motor RLA	1	
Outdoor Fan Motor W	80	
Indoor Fan Motor RLA	2.5	
Indoor Fan Motor W	600	
System Power Input @ Cooling (W)	2150(830 ~ 2850)	
System Power Input @ Heating (W)	2150(405 ~2450)	
MCA: Min. circuit amps (A)	MOCP: Max. over current protection (A)	
RLA: Rated load amps (A)	W: Fan motor rated output (W)	

PIPING

Liquid Size	3/8in (9.52mm)
Gas Size	3/4in (19mm)
Drain Size	5/8in (15.88mm)
Max. Piping Length	164ft (50m)
Max. Height Difference	82ft (25m)
Max. Pre-charged Length	24.6ft (7.5m)
Refrigerant Pre-charged Amount	74.08oz (2100g)
Additional Charge of Refrigerant	0.7oz/ft (65g/m)
Connection Method	Flared

Indoor Unit Dimension

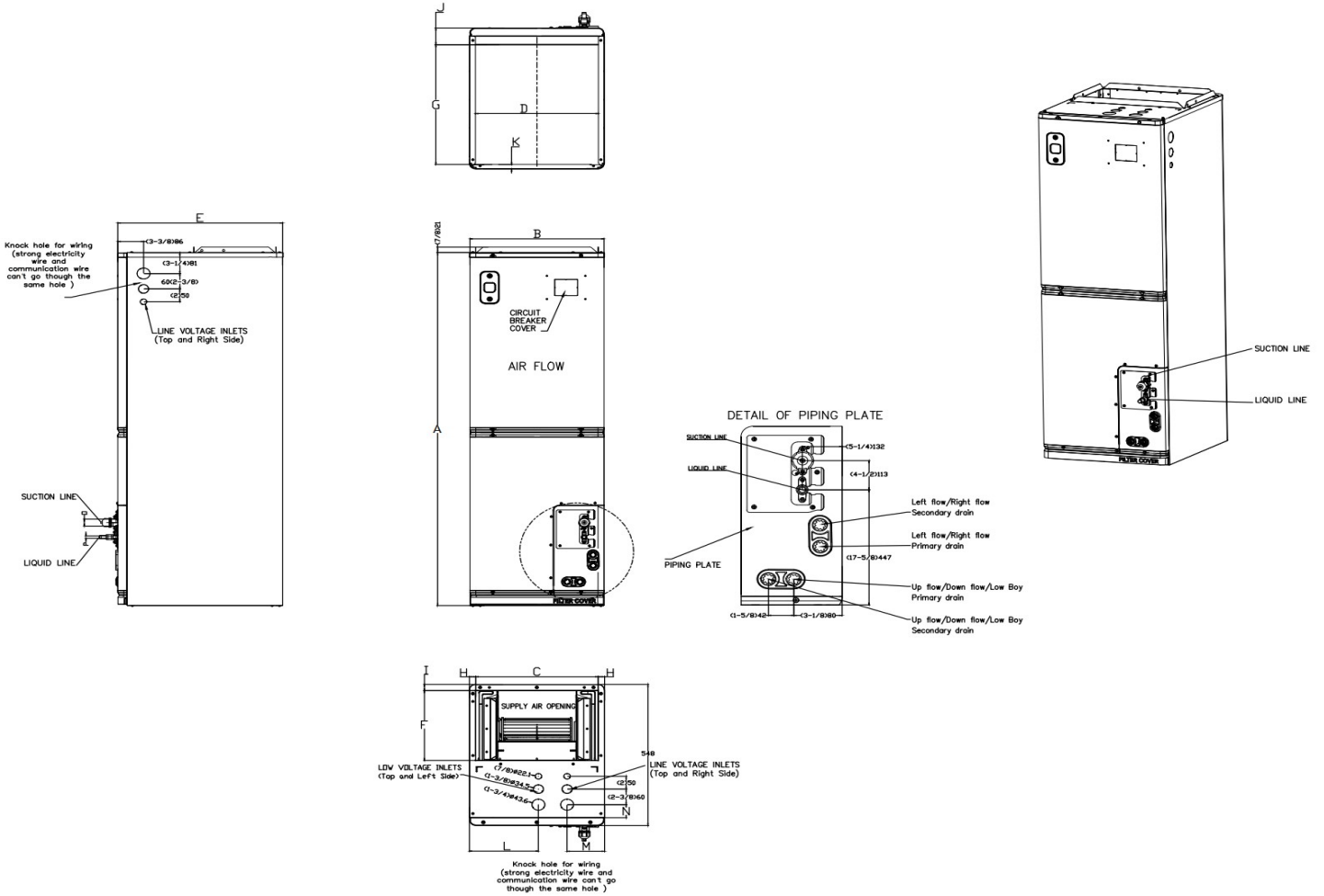

Dimensions	Model(Btu/h)	18K/24K		30K/36K		48K/54K	
		inch	mm	inch	mm	inch	mm
A	Model Height	49-3/4	1263	54	1371	56	1421
B	Model Width	14-1/2	368	17-1/2	445	21-1/2	546
C	Supply Air Opening Width	12-7/8	328	16	405	19-7/8	506
D	Return Air Opening Width	13	331	16	407	20	509
E	Model Depth	21-1/2	546	21-1/2	546	21-1/2	546
F	Supply Air Opening Depth	10-5/8	271	10-5/8	271	10-5/8	271
G	Return Air Opening Depth	18-1/4	465	18-1/4	465	18-1/4	465
H	Supply Air Opening Clearance	7/8	22	7/8	22	7/8	22
I	Supply Air Opening Clearance	1	24	1	24	1	24
J	Return Air Opening Front Clearance	2-1/2	65	2-1/2	65	2-1/2	65
K	Return Air Opening Back Clearance	3/4	18	3/4	18	3/4	18
L	Top cover knock hole	/	/	9	229	10-7/8	275
M	Top cover knock hole	4-1/2	113	4-7/8	124	5-1/8	131
N	Top cover knock hole	2	51	2	51	1-5/8	41
O	Refrigerant piping flareconnection(gas)	3/4	19	3/4	19	3/4	19
P	Refrigerant piping flareconnection(liquid)	3/8	9	3/8	9	3/8	9

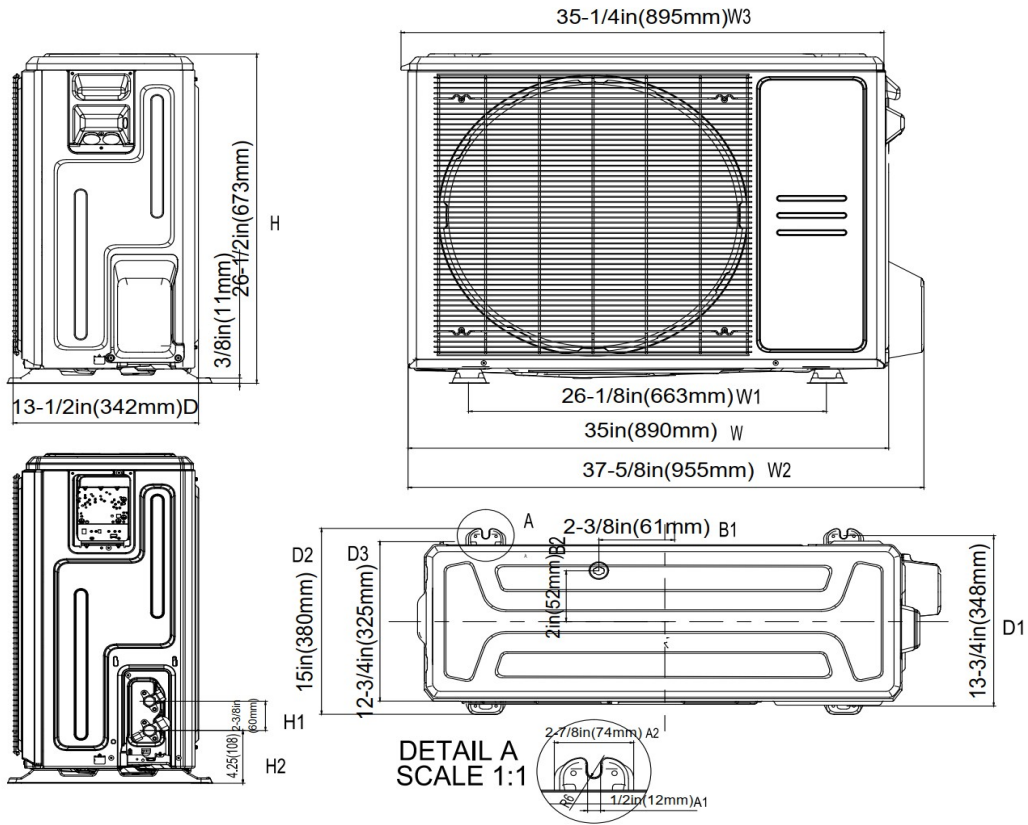

Installation Instruction



Meets all special requirements shown in Installation Clearance Requirements above.

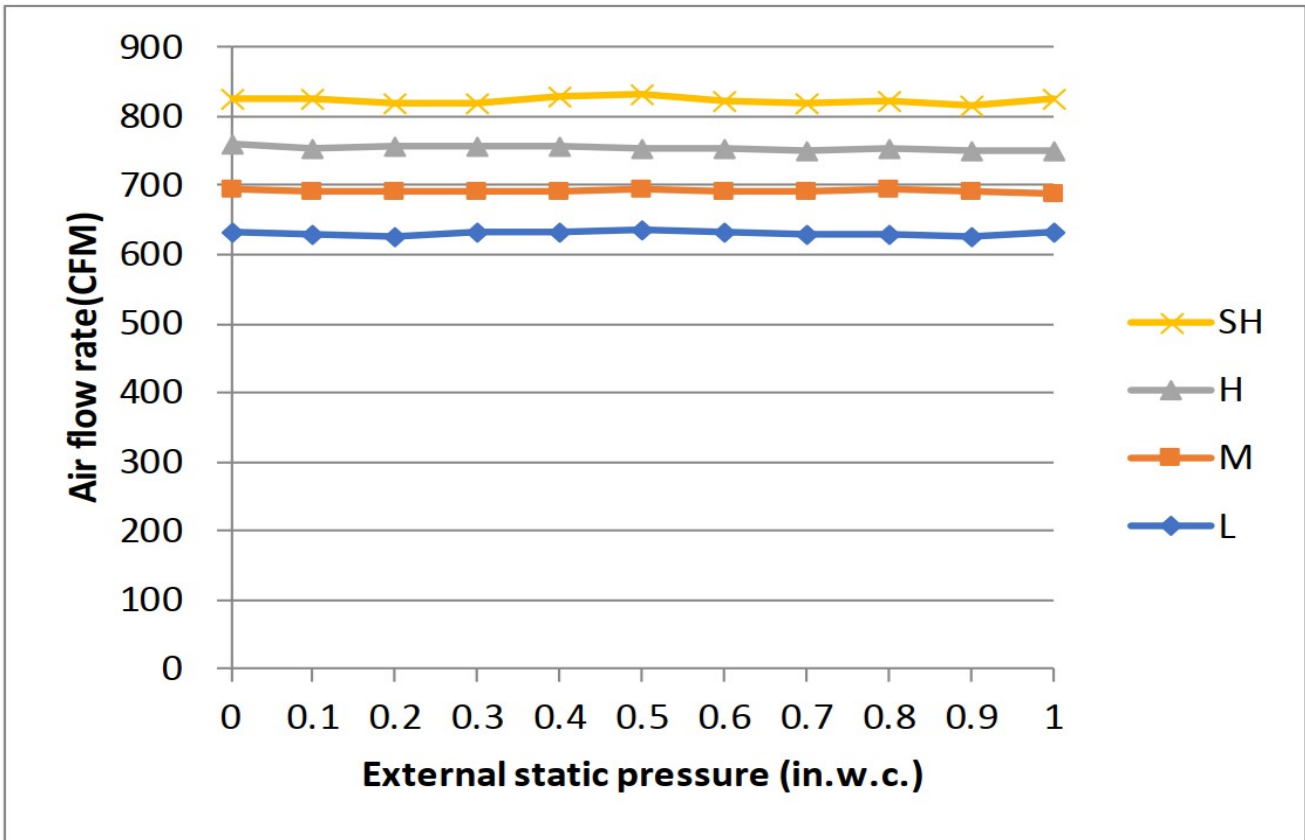

Features

- Multi-position installation: horizontal(left or right), vertical(up or down)
- 115/230V voltage compatible for IDU
- Aluminum Coil
- Constantly Air Flow system up to 1.0 In.W.G
- Optional Auxiliary heat kit up to 25kW
- Easy Maintenance
- Multiple controller options available:
 - Optional two way communication wired controller, programmable:120N(X6)
 - Optional two way communication wired controller, programmable, with built-in WiFi, :120N(X6W)
 - Standard Wireless remote controller
 - Can connect with Third-Party 24V Thermostat
- Adapted to RS485 and 24V communication controllers
- High efficiency up to 19 SEER2, 12.5 EER2, 10.8 HSPF2
- 100% heat output at -13F*
- Chassis heater and crankcase heater pre-bulit as standard

* For AUH3-36N2-BM3E pairing with AUO19-36N2-M3H-S, rated cooling capacity/heating capacity at -13F=100%