

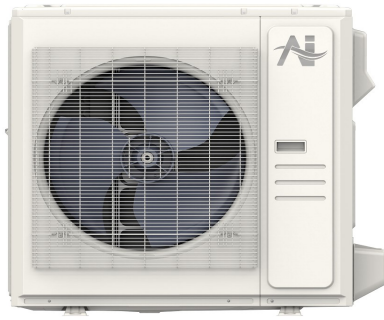

Location: \_\_\_\_\_  
 Engineer: \_\_\_\_\_  
 Submitted to: \_\_\_\_\_  
 Submitted by: \_\_\_\_\_  
 Reference: \_\_\_\_\_

Model Number: AUO19-48N2-M3H / AUH2-48N2-DM3E

Approval: \_\_\_\_\_  
 Date: \_\_\_\_\_  
 Construction: \_\_\_\_\_  
 Unit #: \_\_\_\_\_  
 Drawing #: \_\_\_\_\_



INDOOR SPECIFICATION		
ESP(in.W.G)		0-0.8
Indoor Air Flow (Turbo/H/M/L/S) (CFM)		1601/1472/1283/1095/1095
Indoor Noise Level (T/H/M/L/S) (dBA)		52/52/50/34/34
Dimension (W×D×H)	inch	21 x 24-1/2 x 53
	mm	534 x 622 x 1346
Package (W×D×H)	inch	28 x 26-3/4 x 56-1/2
	mm	710 x 680 x 1435
Net/Gross Weight	lbs	163/191
	kg	73.9/86.6

OUTDOOR SPECIFICATION		
Compressor Type		ROTARY
Refrigerant		R454B
Factory Charge		1800ml
Refrigerant Oil		HAF68D1C
Outdoor Air Flow (Max) (CFM)		3037.1
Outdoor Noise Level (dBA)		65.0
Dimension (W×D×H)	inch	38-5/8 x 16-3/8 x 38-3/8
	mm	980 x 415 x 975
Package (W×D×H)	inch	45-1/8 x 19-5/8 x 42-1/2
	mm	1145 x 500 x 1080
Net/Gross Weight	lbs	201/232
	kg	91.2/105.4

EFFICIENCY			
Cooling		Heating	
SEER2	16.5	HSPF2-4	9.5
EER2	10.5	COP	3.4

PERFORMANCE of Cooling	
Cooling (Btu/hr)	
Rated Capacity	48000
Min/Max Capacity	15600~51000
Moisture Removal	3.85
Standard Operating Range	-22°F~122°F (-30°C~50°C)
Rated Cooling Conditions:	Indoor: 80°F DB/67°F WB Outdoor: 95°F DB/75°F WB

PERFORMANCE of Heating	
Heating (Btu/hr)	
1. @ 47°F Rated (Min/Max)	50000(15500~57300)
2. @ 17°F Rated	37000
3. @ 5°F Max: Capacity / COP	46000/1.9
Standard Operating Range	-22°F ~75°F (-30°C~24°C)
1. Rated Heating Conditions:	Indoor: 70°F DB/60°F WB Outdoor: 47°F DB/43°F WB
2. Rated Heating Conditions:	Indoor: 70°F DB/60°F WB Outdoor: 17°F DB/15°F WB
3. Heating Conditions, Compressor Operating at Max. Frequency	Indoor: 70°F DB/60°F WB Outdoor: 5°F DB/5°F WB

ELECTRICAL	
Indoor Power Supply	115/208/230V,60Hz,1Ph
Indoor MCA 115V/(208/230V)	14.5/11.0
Indoor MOP	15
Outdoor Power Supply	208/230V,60Hz,1Ph
Outdoor MCA	38
Outdoor MOP	40
Communication Wiring	AWG 20-2
Compressor RLA	28
Outdoor Fan Motor RLA	2
Outdoor Fan Motor W	250
Indoor Fan Motor RLA	7.8
Indoor Fan Motor W	750
System Power Input @ Cooling (W)	4690(1345 ~ 5180)
System Power Input @ Heating (W)	4750(1045 ~5200)
MCA: Min. circuit amps (A)	MOCP: Max. over current protection (A)
RLA: Rated load amps (A)	W: Fan motor rated output (W)

PIPING	
Liquid Size	3/8in (9.52mm)
Gas Size	3/4in (19mm)
Drain Size	5/8in (15.88mm)
Max. Piping Length	246ft (75m)
Max. Height Difference	98.4ft (30m)
Max. Pre-charged Length	24.6ft (7.5m)
Refrigerant Pre-charged Amount	134.04oz (3800g)
Additional Charge of Refrigerant	0.7oz/ft (65g/m)
Connection Method	Flared

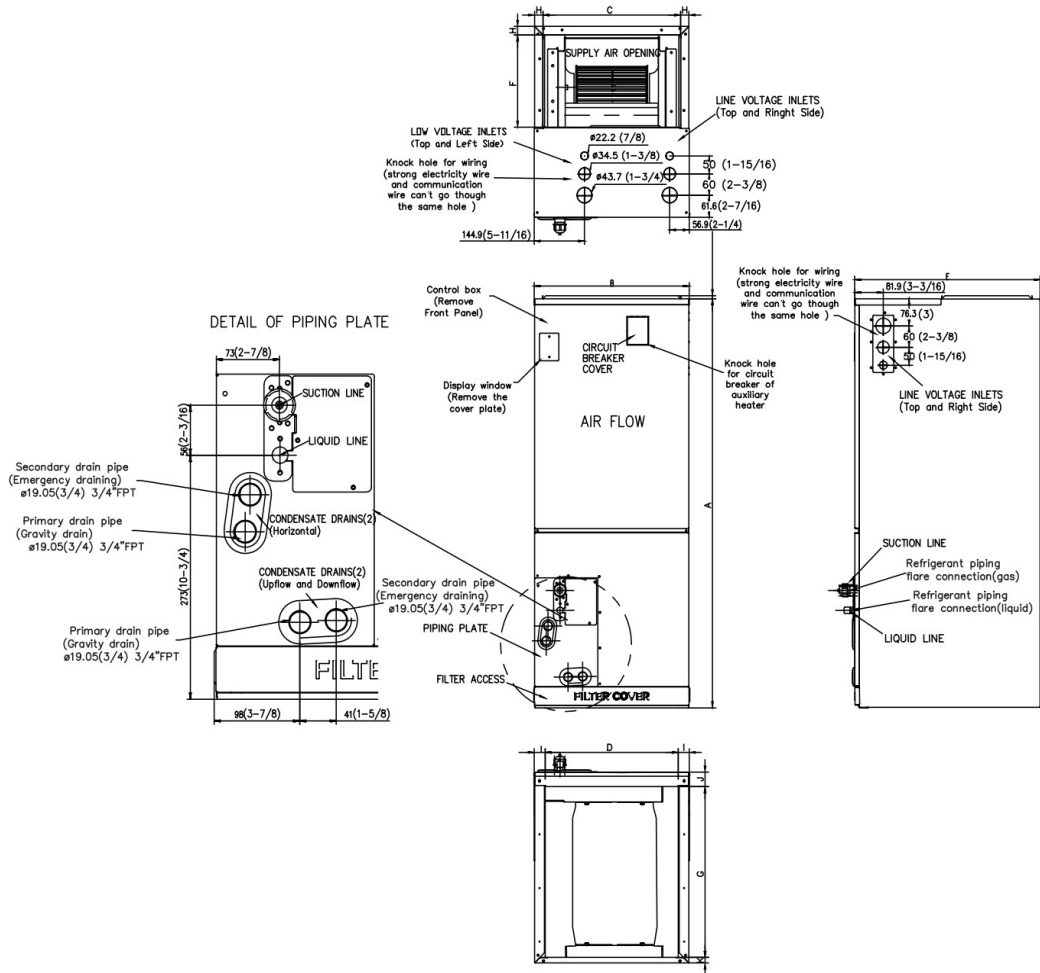

Dimensions	Model	18k/24k		30k/36k		48k/60k	
		inch	mm	inch	mm	inch	mm
A	Model Height	45	1143	49	1245	53	1346
B	Model Width	17-1/2	445	21	534	24-1/2	622
C	Supply Air Opening Width	15-5/8	397	19-1/8	486	22-5/8	575
D	Return Air Opening Width	15-1/8	384	18-5/8	473	22-1/8	562
E	Model Depth	21	534	21	534	21	534
F	Supply Air Opening Depth	10-1/4	260	10-1/4	260	10-1/4	260
G	Return Air Opening Depth	18-3/4	476	18-3/4	476	18-3/4	476
H	Supply Air Opening Clearance	15/16	24	15/16	24	15/16	24
I	Return Air Opening Side Clearance	1-1/4	32	1-1/4	32	1-1/8	28
J	Return Air Opening Front Clearance	1-1/2	38	1-5/8	41	1-5/8	41
K	Return Air Opening Back Clearance	5/8	16	5/8	16	3/4	19

## Outdoor Unit Dimension

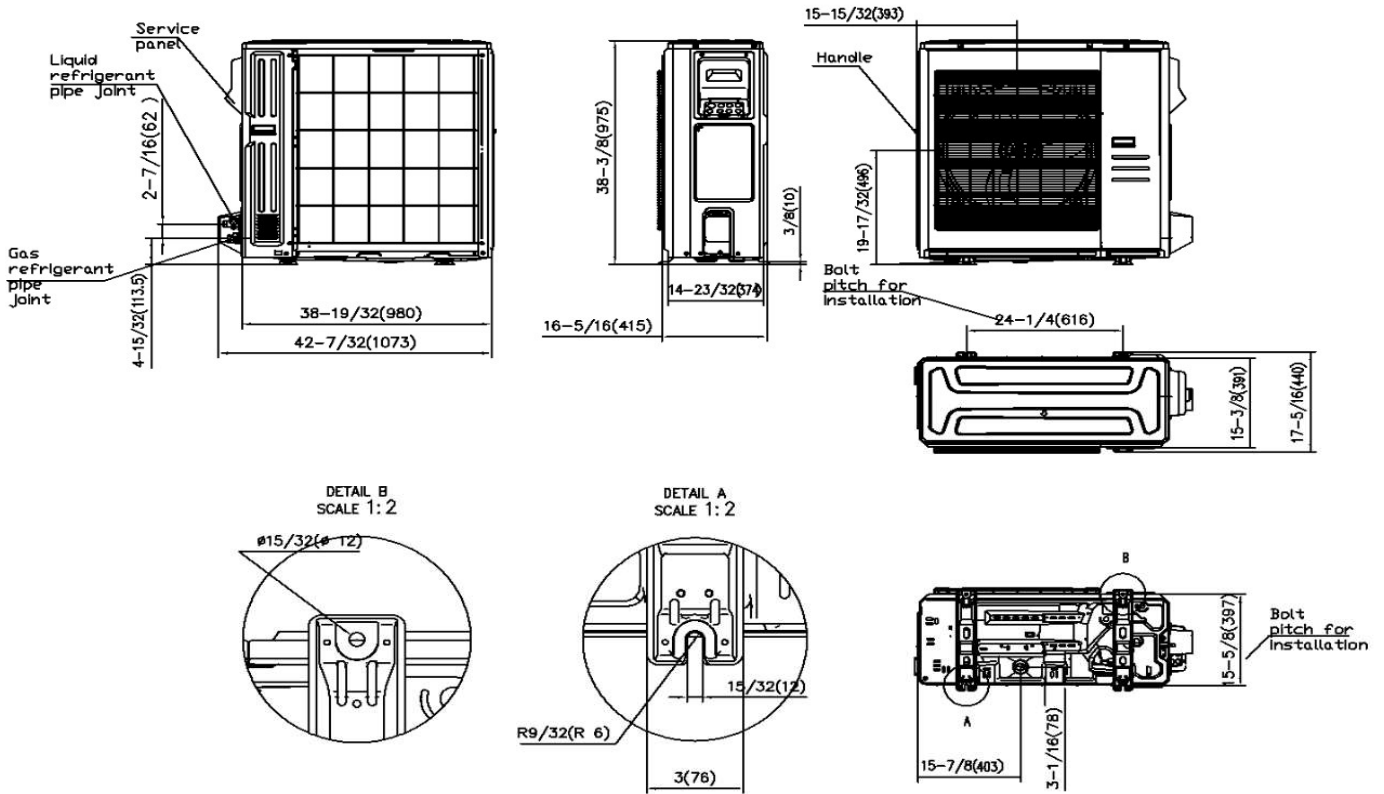

## Installation Instruction

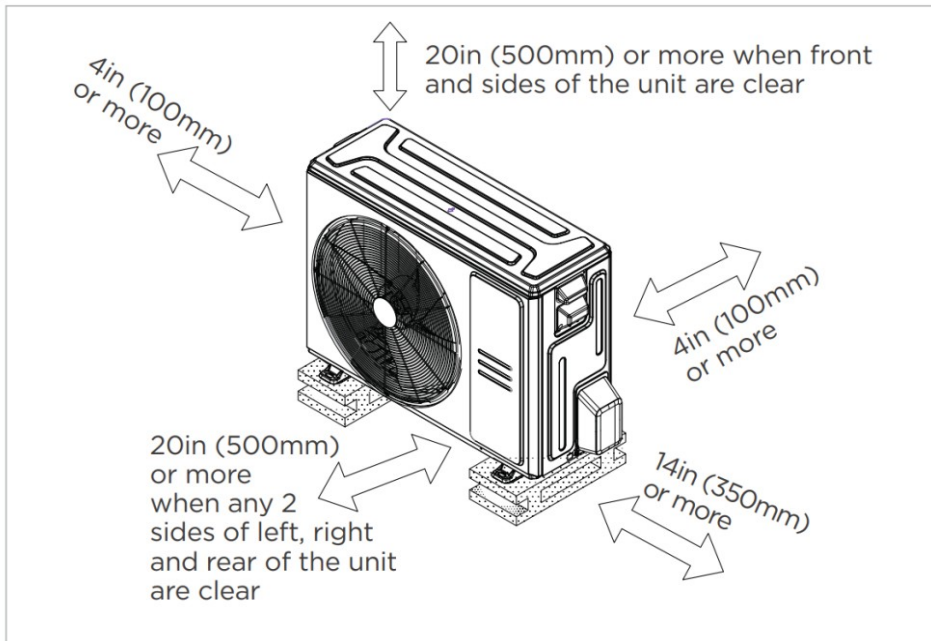

- Meets all special requirements shown in Installation Clearance Requirements above.

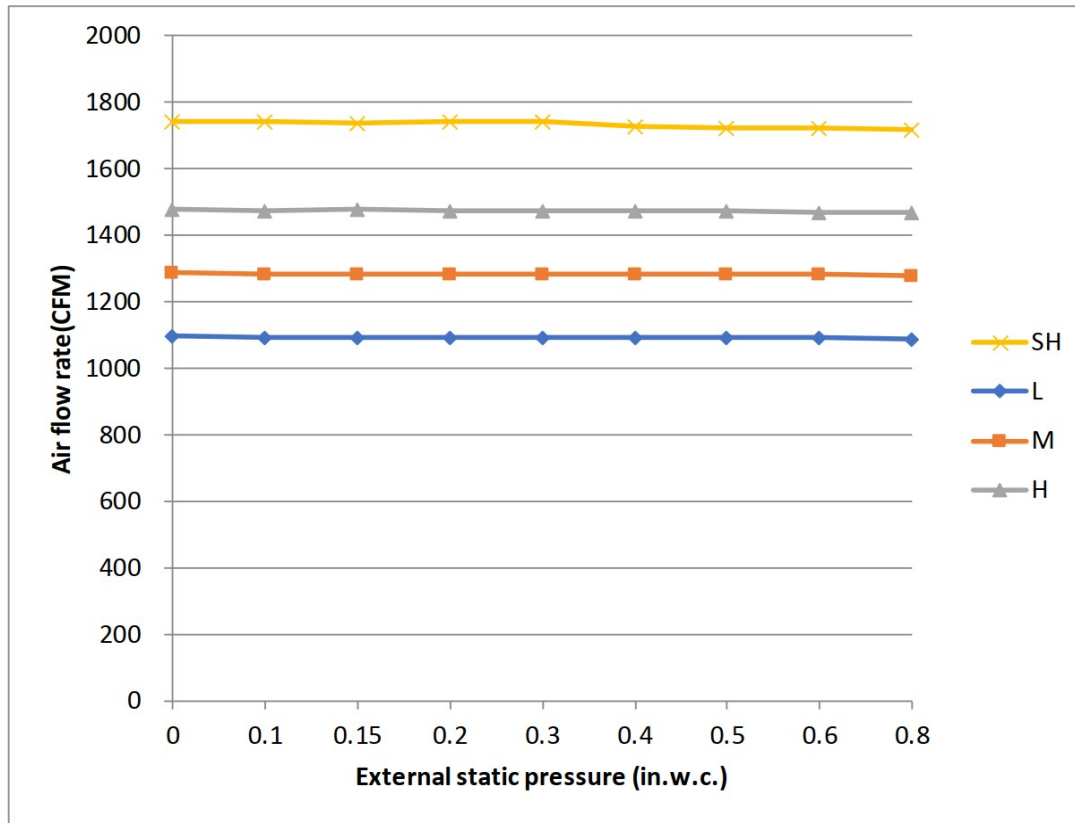

Features

- Multi-position installation: horizontal(left or right), vertical( up or down)
- Aluminum Coil
- Constantly Air Flow system up to 0.80 In.W.G
- 1 inch thick R4.2 fiberglass free insulation, reduce condensation and increase efficiency(optional)
- Optional Auxiliary heat kit up to 25kW
- Easy Maintenance
- Multiple controller options available:
  - Optional two way communication wired controller, programmable:120N(X6)
  - Optional two way communication wired controller, programmable, with built-in WiFi, :120N(X6W)
  - Standard Wireless remote controller
  - Can connect with Third-Party 24V Thermostat
- Adapted to RS485 and 24V communication controllers
- High efficiency up to 19 SEER2, 12.5 EER2, 10.3 HSPF2
- 100% heat output at -4F\*
- Chassis heater and crankcase heater pre-bulit as standard

\* For 36K model, rated cooling capacity/heating capacity at -4F=100%