

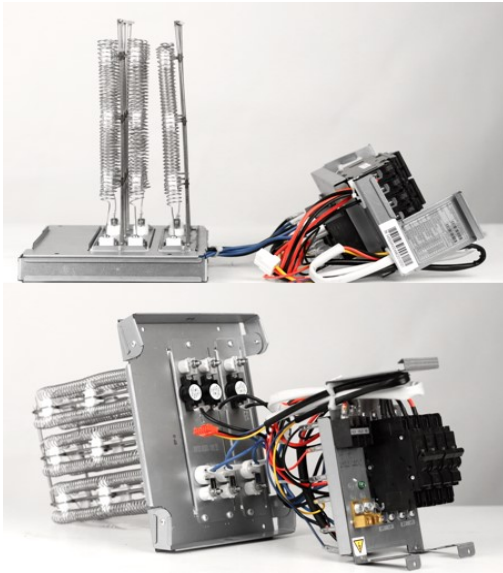

Location: _____
 Engineer: _____
 Submitted to: _____
 Submitted by: _____
 Reference: _____

Model Number: EAH-15F(UL)

Approval: _____
 Date: _____
 Construction: _____
 Unit #: _____
 Drawing #: _____



SPECS		
Normal Operational Voltage	(V, Ph, Hz)	208 / 230, 1, 60
Current	A	54.1 / 60.0
Heat Power	KW	11.25 / 13.8
MCA(Circuit 1)	A	23.0 / 27.0
MAX. FUSE(Circuit 1)	A	25.0 / 30.0
MCA(Circuit 2)	A	46.0 / 53.0
MAX. FUSE(Circuit 2)	A	50.0 / 60.0
Heater dimension (W×D×H)	inch	22 x 10-5/8 x 8-1/8
	mm	559 x 269 x 205
Packaging dimension (W×D×H)	inch	25-5/8 x 15 x 10-1/4
	mm	650 x 380 x 260
Net Weight	lbs	7.1
	kg	3.5
Gross Weight	lbs	15.4
	kg	7.0

Heater dimension

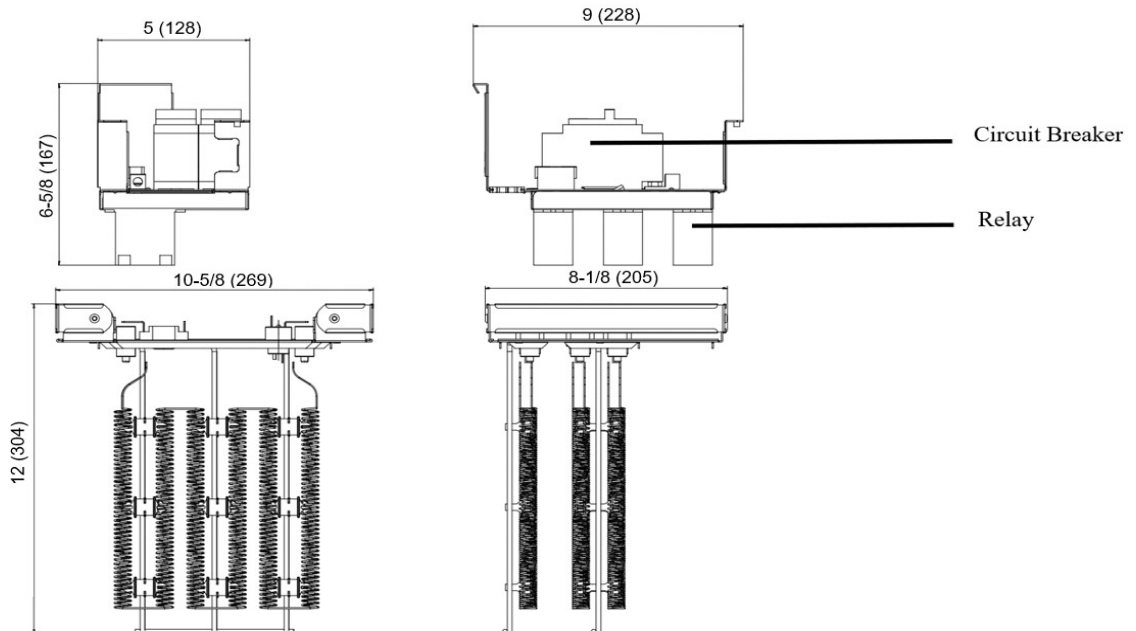

15KW HEAT KIT

 : THERMAL LINK

 : THERMAL CUT-OUT, SELF-RESETTING

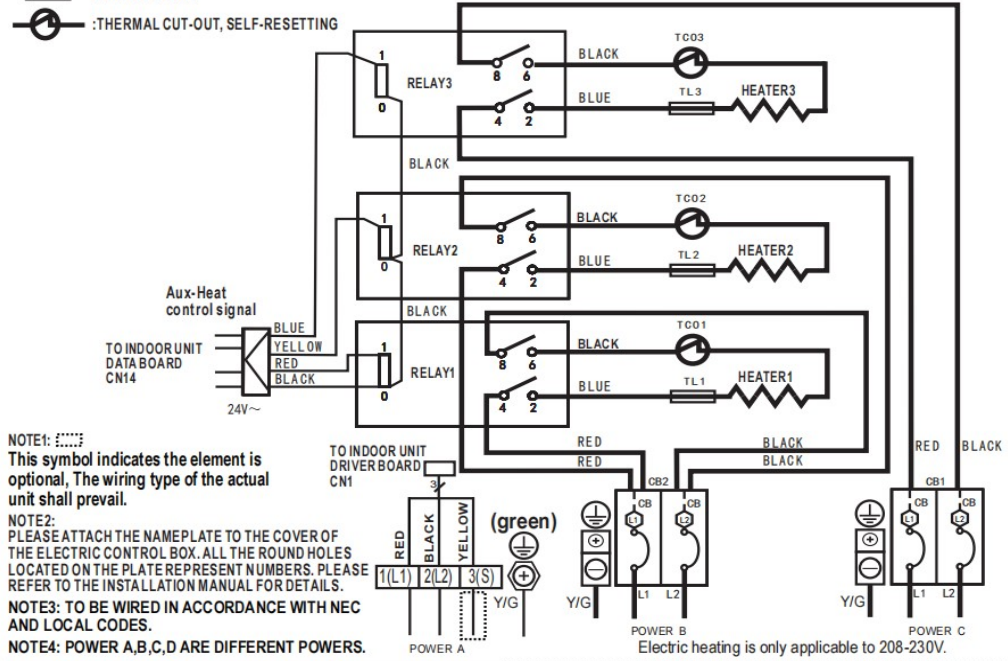







NOTE1: 
 This symbol indicates the element is optional. The wiring type of the actual unit shall prevail.

NOTE2:
 PLEASE ATTACH THE NAMEPLATE TO THE COVER OF THE ELECTRIC CONTROL BOX. ALL THE ROUND HOLES LOCATED ON THE PLATE REPRESENT NUMBERS. PLEASE REFER TO THE INSTALLATION MANUAL FOR DETAILS.

NOTE3: TO BE WIRED IN ACCORDANCE WITH NEC AND LOCAL CODES.

NOTE4: POWER A,B,C,D ARE DIFFERENT POWERS.

Round hole number	Relay number	Round hole number	Circuit breaker number
	RELAY 1		CB1
	RELAY 2		CB2
	RELAY 3		
			
			

The wiring mode of power supply A shall be based on the type of original wiring terminal of AHU; for type A, S position must be connected to the outdoor S; for type B, S position shall not be connected. When using 115VAC, connect L1 and L2 (L2 is used as N).

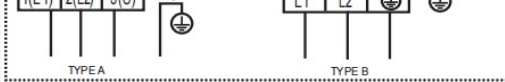

Electric heating is only applicable to 208-230V.