

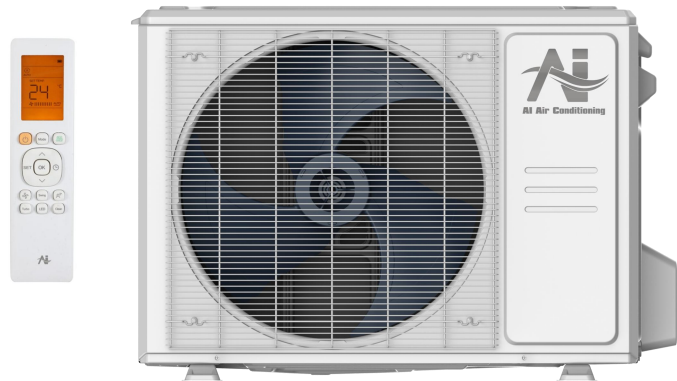

Location: _____
 Engineer: _____
 Submitted to: _____
 Submitted by: _____
 Reference: _____

Model Number: AO35-06N2-M1H / AW35-06N2-M1

Approval: _____
 Date: _____
 Construction: _____
 Unit #: _____
 Drawing #: _____

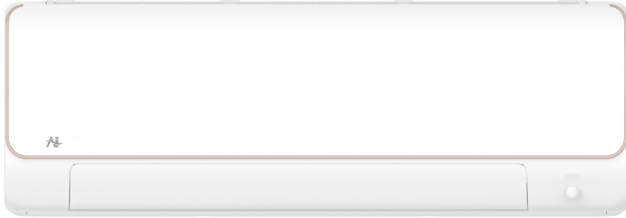

INDOOR SPECIFICATION		
Indoor Air Flow (Turbo/H/M/L/S) (CFM)		559/424/212/153/153
Indoor Noise Level (T/H/M/L/S) (dBA)		42/42/33/23/19
Dimension (W×D×H)	inch	40 x 9-3/4 x 12-1/2
	mm	1017 x 248 x 319
Package (W×D×H)	inch	43-1/8 x 12-3/4 x 15-3/4
	mm	1095 x 325 x 400
Net/Gross Weight	lbs	28/37
	kg	12.8/16.7

OUTDOOR SPECIFICATION		
Compressor Type	ROTARY	
Refrigerant	R454B	
Factory Charge	500ml	
Refrigerant Oil	VG74	
Outdoor Air Flow (Max) (CFM)	1470.6	
Outdoor Noise Level (dBA)	57.0	
Dimension (W×D×H)	inch	35 x 13-1/2 x 26-1/2
	mm	890 x 342 x 673
Package (W×D×H)	inch	39-1/8 x 15-5/8 x 29-1/8
	mm	995 x 398 x 740
Net/Gross Weight	lbs	100/108
	kg	45.2/48.9

EFFICIENCY			
Cooling		Heating	
SEER2	35.0	HSPF2-4	30.0
EER2	17.4	COP	4.0

PERFORMANCE of Cooling	
Cooling (Btu/hr)	
Rated Capacity	6000
Min/Max Capacity	3100~16500
Moisture Removal	0.5
Standard Operating Range	-22°F~122°F (-30°C~50°C)
Rated Cooling Conditions:	Indoor: 80°F DB/67°F WB Outdoor: 95°F DB/75°F WB

PERFORMANCE of Heating	
Heating (Btu/hr)	
1. @ 47°F Rated (Min/Max)	9000(4100~17200)
2. @ 17°F Rated	11000
3. @ 5°F Max: Capacity / COP	13500/2.00
Standard Operating Range	-22°F~75°F (-30°C~24°C)
1. Rated Heating Conditions:	Indoor: 70°F DB/60°F WB Outdoor: 47°F DB/43°F WB
2. Rated Heating Conditions:	Indoor: 70°F DB/60°F WB Outdoor: 17°F DB/15°F WB
3. Heating Conditions, Compressor Operating at Max. Frequency	Indoor: 70°F DB/60°F WB Outdoor: 5°F DB/5°F WB

ELECTRICAL	
Power Supply	208/230V,60Hz,1Ph
System MCA	16
Connection Wiring	AWG 14-4
System MOCP	20
Compressor RLA	11.6
Outdoor Fan Motor RLA	0.7
Outdoor Fan Motor W	80
Indoor Fan Motor RLA	0.7
Indoor Fan Motor W	60
System Power Input @ Cooling (W)	343(180 ~ 1380)
System Power Input @ Heating (W)	660(200 ~ 1585)
MCA: Min. circuit amps (A)	MOCP: Max. over current protection (A)
RLA: Rated load amps (A)	W: Fan motor rated output (W)

PIPING	
Liquid Size	1/4in (6.35mm)
Gas Size	3/8in (9.52mm)
Drain Size	5/8in (15.88mm)
Max. Piping Length	82ft (25m)
Max. Height Difference	49.2ft (15m)
Max. Pre-charged Length	24.6ft (7.5m)
Refrigerant Pre-charged Amount	44.09oz (1.25g)
Additional Charge of Refrigerant	0.16oz/ft (15g/m)
Connection Method	Flared

Indoor Unit Dimension

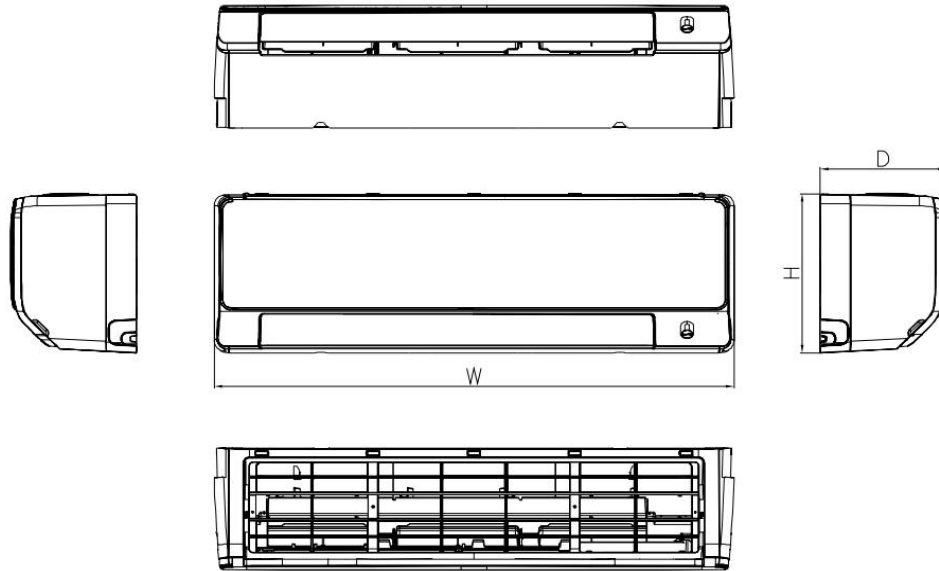

Capacity	Body Code	Unit	W	D	H
6k~12k	C	mm	1017	248	319
		inch	40	9-3/4	12-1/2
18k	D	mm	1190	285	371
		inch	46-7/8	11-1/4	14-5/8

Installation Instruction

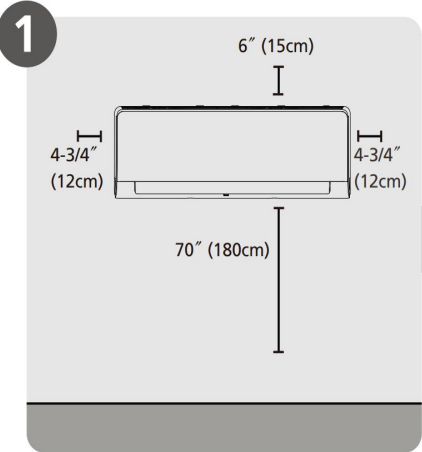

Select Installation Location

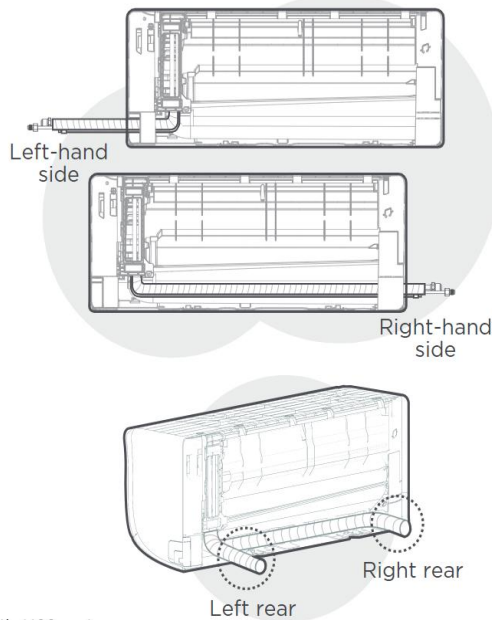

NOTE:
Based on the position of the wall hole relative to the mounting plate, choose the side from which the piping will exit the unit. You have four options for the exit direction of the piping.

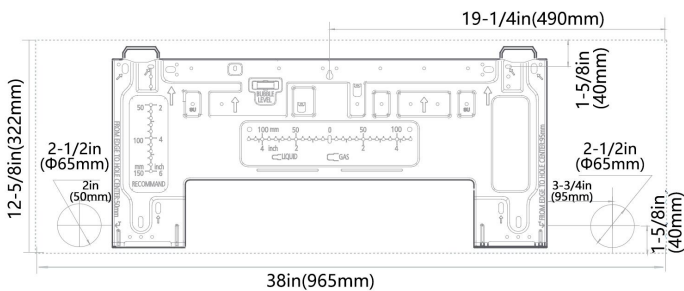

NOTE:
When the gas side connective pipe is Φ (5/8in)16mm or more, the wall hole should be (3-1/2in)90mm.

Outdoor Unit Dimension

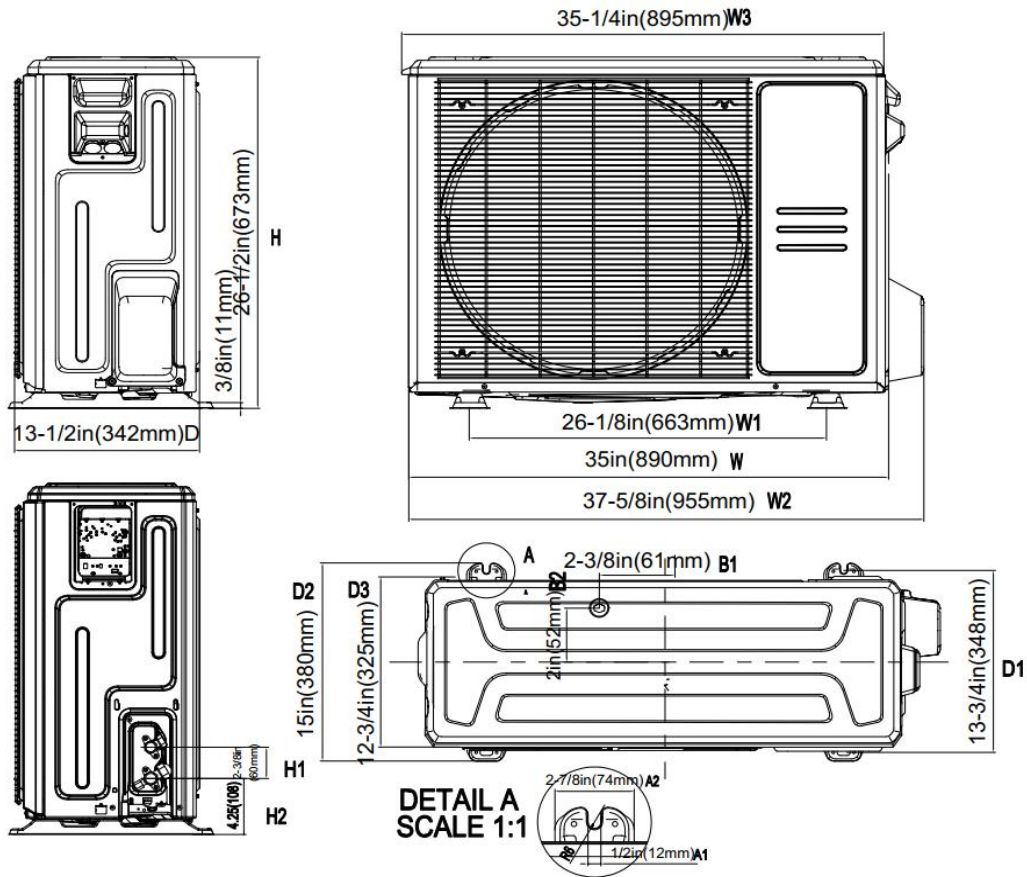

Installation Instruction

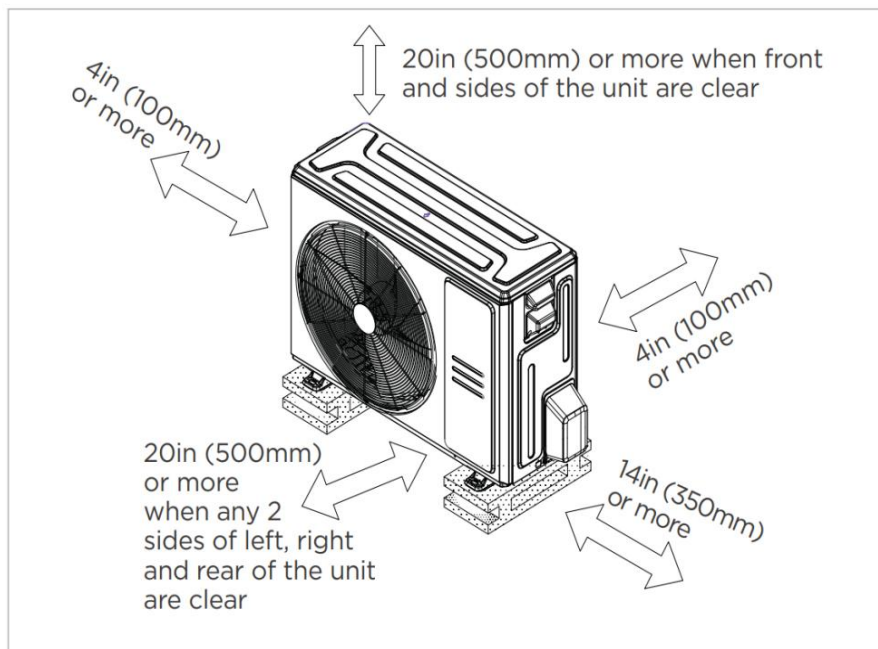

- ☑ Meets all special requirements shown in Installation Clearance Requirements above.

- Indoor unit use TU1 copper coil, better anti corrosion.
- 1~100% stepless adjustable fan speed setting
- WiFi capability: Built-in WiFi modular or wired controller with WiFi function
- OTA function: can upgrade the program version anytime
- Multiple controller options available:
 - Optional two way communication wired controller, programmable:120N(X6)
 - Optional two way communication wired controller, programmable, with built-in WiFi, :120N(X6W)
 - Optional Infrared wired controller: 120L
 - Standard Wireless remote controller RG10
 - Optional 24V interface kit, can connect with Third-Party 24V Thermostat