

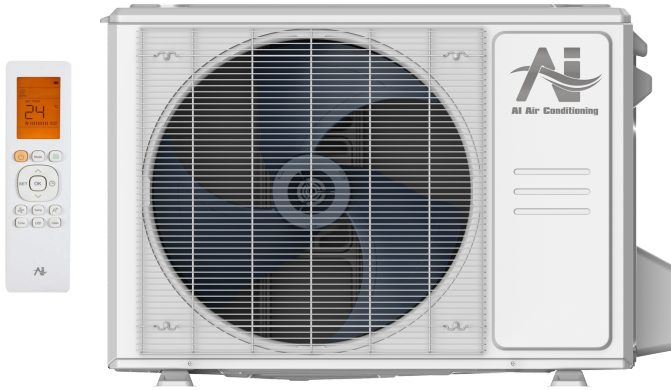

Location: \_\_\_\_\_  
 Engineer: \_\_\_\_\_  
 Submitted to: \_\_\_\_\_  
 Submitted by: \_\_\_\_\_  
 Reference: \_\_\_\_\_

Model Number: AO21-09N2-M1 / AW21-09N2-M1

Approval: \_\_\_\_\_  
 Date: \_\_\_\_\_  
 Construction: \_\_\_\_\_  
 Unit #: \_\_\_\_\_  
 Drawing #: \_\_\_\_\_

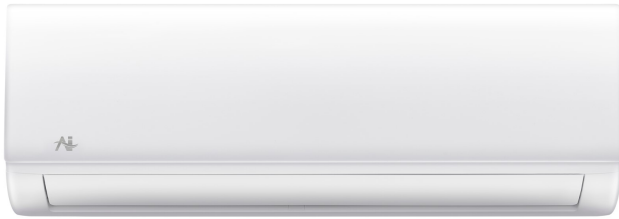

| INDOOR SPECIFICATION                  |                     |                          |
|---------------------------------------|---------------------|--------------------------|
| Indoor Air Flow (Turbo/H/M/L/S) (CFM) | 306/247/177/141/141 |                          |
| Indoor Noise Level (T/H/M/L/S) (dBA)  | 43/39/33/24/20      |                          |
| Dimension (WxDxH)                     | inch                | 28-3/4 x 7-7/8 x 11-1/2  |
|                                       | mm                  | 729 x 200 x 292          |
| Package (WxDxH)                       | inch                | 31-1/8 x 10-5/8 x 14-3/4 |
|                                       | mm                  | 790 x 270 x 375          |
| Net/Gross Weight                      | lbs                 | 18/23                    |
|                                       | kg                  | 8.2/10.5                 |

| OUTDOOR SPECIFICATION        |        |                          |
|------------------------------|--------|--------------------------|
| Compressor Type              | ROTARY |                          |
| Refrigerant                  | R454B  |                          |
| Factory Charge               | 310ml  |                          |
| Refrigerant Oil              | VG74   |                          |
| Outdoor Air Flow (Max) (CFM) | 1294.1 |                          |
| Outdoor Noise Level (dBA)    | 53.5   |                          |
| Dimension (WxDxH)            | inch   | 30-1/8 x 11-7/8 x 21-7/8 |
|                              | mm     | 765 x 303 x 555          |
| Package (WxDxH)              | inch   | 34-7/8 x 13-1/4 x 24     |
|                              | mm     | 887 x 337 x 610          |
| Net/Gross Weight             | lbs    | 54/60                    |
|                              | kg     | 24.6/27.1                |

| EFFICIENCY |      |         |     |
|------------|------|---------|-----|
| Cooling    |      | Heating |     |
| SEER2      | 21.6 | HSPF2-4 | 9.4 |
| EER2       | 12.6 | COP     | 3.3 |

| PERFORMANCE of Cooling    |   |
|---------------------------|---|
| Cooling (Btu/hr)          |   |
| Rated Capacity            | 9000  |
| Min/Max Capacity          | 2900~10500  |
| Moisture Removal          | 0.9   |
| Standard Operating Range  | 5°F~122°F (-15°C~50°C)                              |
| Rated Cooling Conditions: | Indoor: 80°F DB/67°F WB<br>Outdoor: 95°F DB/75°F WB |

| PERFORMANCE of Heating  |   |
|---|---|
| Heating (Btu/hr)  |   |
| 1. @ 47°F Rated (Min/Max)                                     | 10000(2400~11200)                                   |
| 2. @ 17°F Rated   | 6600  |
| 3. @ 5°F Max: Capacity / COP                                  | 7000/2.00   |
| Standard Operating Range                                      | 5°F~75°F (-15°C~24°C)                               |
| 1. Rated Heating Conditions:                                  | Indoor: 70°F DB/60°F WB<br>Outdoor: 47°F DB/43°F WB |
| 2. Rated Heating Conditions:                                  | Indoor: 70°F DB/60°F WB<br>Outdoor: 17°F DB/15°F WB |
| 3. Heating Conditions, Compressor Operating at Max. Frequency | Indoor: 70°F DB/60°F WB<br>Outdoor: 5°F DB/5°F WB   |

| ELECTRICAL                       |  |
|----------------------------------|--|
| Power Supply                     | 208/230V,60Hz,1Ph                      |
| System MCA                       | 12                                     |
| Connection Wiring                | AWG 14-4                               |
| System MOCP                      | 15                                     |
| Compressor RLA                   | 7.0                                    |
| Outdoor Fan Motor RLA            | 0.3                                    |
| Outdoor Fan Motor W              | 34                                     |
| Indoor Fan Motor RLA             | 0.3                                    |
| Indoor Fan Motor W               | 20                                     |
| System Power Input @ Cooling (W) | 714(300 ~ 880)                         |
| System Power Input @ Heating (W) | 896(320 ~1100)                         |
| MCA: Min. circuit amps (A)       | MOCP: Max. over current protection (A) |
| RLA: Rated load amps (A)         | W: Fan motor rated output (W)          |

| PIPING                           |                   |
|----------------------------------|-------------------|
| Liquid Size                      | 1/4in (6.35mm)    |
| Gas Size                         | 3/8in (9.52mm)    |
| Drain Size                       | 5/8in (15.88mm)   |
| Max. Piping Length               | 82ft (25m)        |
| Max. Height Difference           | 49.2ft (15m)      |
| Max. Pre-charged Length          | 24.6ft (7.5m)     |
| Refrigerant Pre-charged Amount   | 21.52oz (610g)    |
| Additional Charge of Refrigerant | 0.16oz/ft (15g/m) |
| Connection Method                | Flared            |

## Indoor Unit Dimension

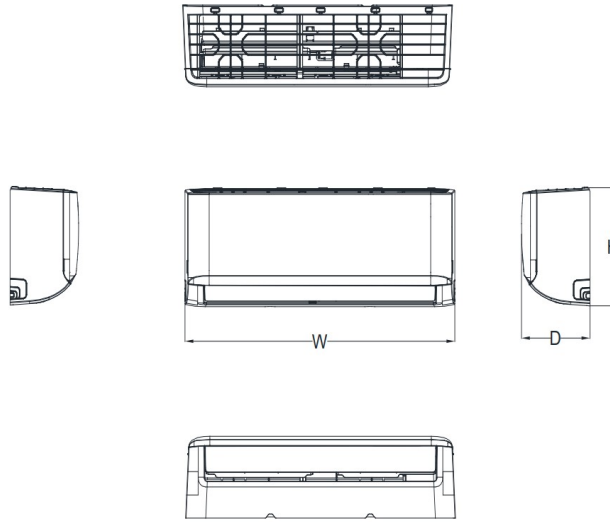

| Capacity | Body Code | W(inch/mm)       | D(mm/inch)     | H(mm/inch)      |
|----------|-----------|------------------|----------------|-----------------|
| 6K~9K    | A         | 28-3/4in /729mm  | 7-7/8in /200mm | 11-1/2in /292mm |
| 9K~12K   | B         | 31-5/8in /802mm  | 7-7/8in /200mm | 11-5/8in /295mm |
| 18K      | C         | 38-1/4in /971mm  | 9in/228mm      | 12-5/8in /321mm |
| 18K~24K  | D         | 42-5/8in /1082mm | 9-1/4in/234mm  | 13-1/4in /337mm |
| 30K~36K  | F         | 49-5/8in /1259mm | 11-1/8in/283mm | 14-1/4in /362mm |

## Installation Instruction

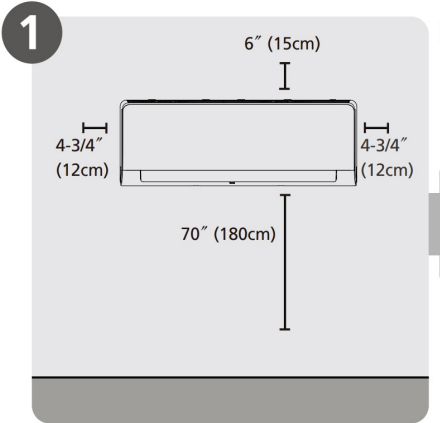

### Select Installation Location

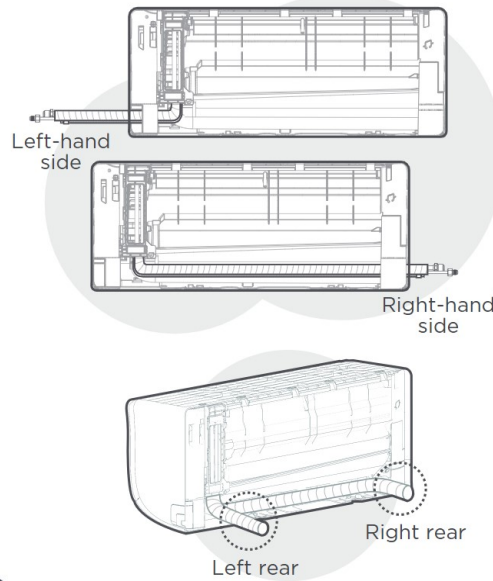

**NOTE:**  
Based on the position of the wall hole relative to the mounting plate, choose the side from which the piping will exit the unit. You have four options for the exit direction of the piping.

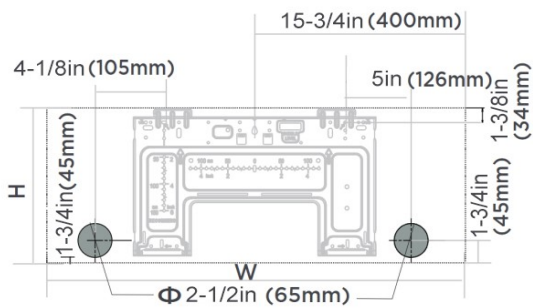

**Indoor unit dimensions(WxH):**  
28-3/4in(729mm)x11-1/2in(293mm)

**NOTE:**  
When the gas side connective pipe is  $\Phi$  (5/8in)16mm or more, the wall hole should be (3-1/2in)90mm.

## Outdoor Unit Dimension

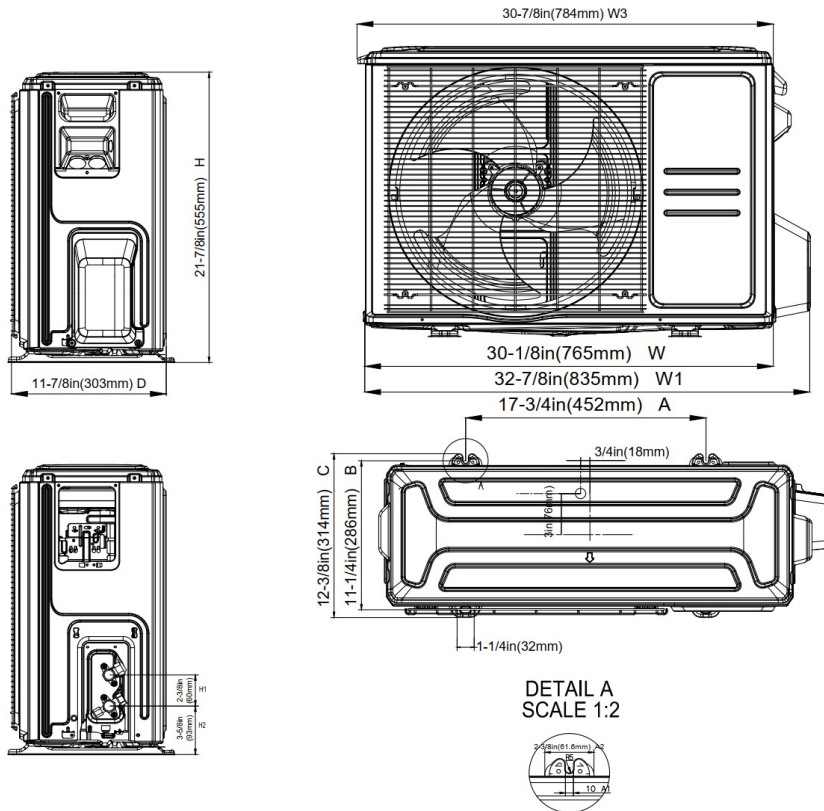

## Installation Instruction

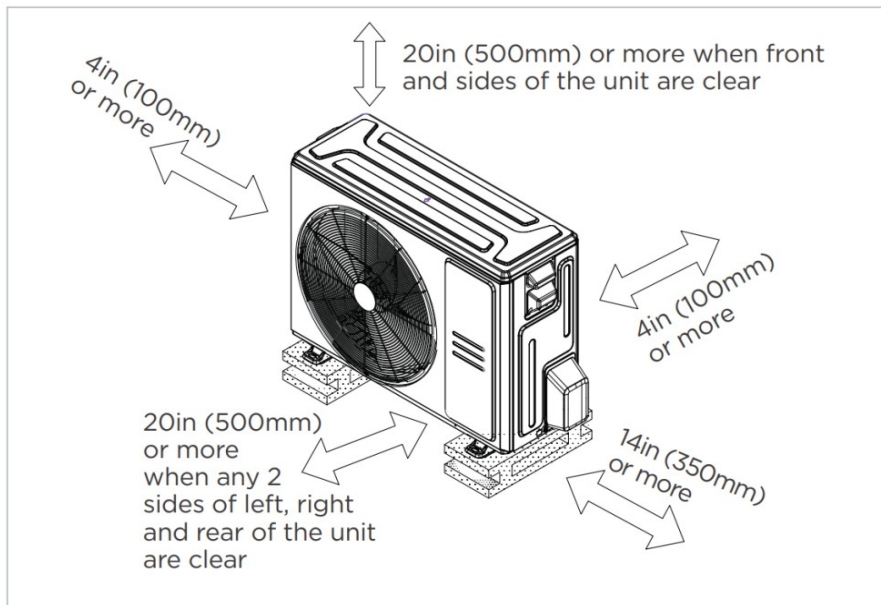

- Meets all special requirements shown in Installation Clearance Requirements above.

- Indoor unit use TU1 copper coil, better anti corrosion.
- 1~100% stepless adjustable fan speed setting
- WiFi capability: Built-in WiFi modular or wired controller with WiFi function
- OTA function: can upgrade the program version anytime
- Multiple controller options available:
  - Optional two way communication wired controller, programmable:120N(X6)
  - Optional two way communication wired controller, programmable, with built-in WiFi, :120N(X6W)
  - Optional Infrared wired controller: 120L
  - Standard Wireless remote controller RG10
  - Optional 24V interface kit, can connect with Third-Party 24V Thermostat