

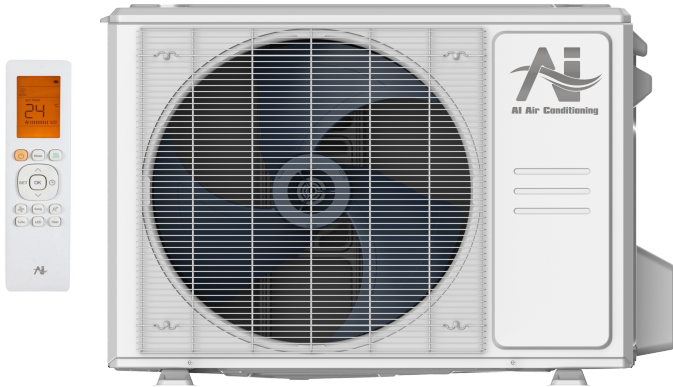

Location: _____
 Engineer: _____
 Submitted to: _____
 Submitted by: _____
 Reference: _____

Model Number: AO21-12N2-M1 / AW21-12N2-M1

Approval: _____
 Date: _____
 Construction: _____
 Unit #: _____
 Drawing #: _____

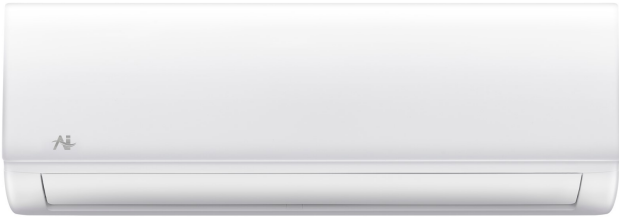

INDOOR SPECIFICATION		
Indoor Air Flow (Turbo/H/M/L/S) (CFM)		347/294/194/153/153
Indoor Noise Level (T/H/M/L/S) (dBA)		46/41/35/24/19
Dimension (WxDxH)	inch	31-5/8 x 7-7/8 x 11-5/8
	mm	802 x 200 x 295
Package (WxDxH)	inch	34-1/2 x 11-1/4 x 15
	mm	875 x 285 x 380
Net/Gross Weight	lbs	19/25
	kg	8.6/11.4

OUTDOOR SPECIFICATION		
Compressor Type		ROTARY
Refrigerant		R454B
Factory Charge		300ml
Refrigerant Oil		VG74
Outdoor Air Flow (Max) (CFM)		1235.3
Outdoor Noise Level (dBA)		53.0
Dimension (WxDxH)	inch	30-1/8 x 11-7/8 x 21-7/8
	mm	765 x 303 x 555
Package (WxDxH)	inch	34-7/8 x 13-1/4 x 24
	mm	887 x 337 x 610
Net/Gross Weight	lbs	59/64
	kg	26.8/29.2

EFFICIENCY			
Cooling		Heating	
SEER2	21.3	HSPF2-4	9.2
EER2	10.8	COP	3.3

PERFORMANCE of Cooling	
Cooling (Btu/hr)	
Rated Capacity	12000
Min/Max Capacity	2700~13800
Moisture Removal	1.4
Standard Operating Range	5°F~122°F (-15°C~50°C)
Rated Cooling Conditions:	Indoor: 80°F DB/67°F WB Outdoor: 95°F DB/75°F WB

PERFORMANCE of Heating	
Heating (Btu/hr)	
1. @ 47°F Rated (Min/Max)	12000(4200~14100)
2. @ 17°F Rated	8300
3. @ 5°F Max: Capacity / COP	8000/1.80
Standard Operating Range	5°F~75°F (-15°C~24°C)
1. Rated Heating Conditions:	Indoor: 70°F DB/60°F WB Outdoor: 47°F DB/43°F WB
2. Rated Heating Conditions:	Indoor: 70°F DB/60°F WB Outdoor: 17°F DB/15°F WB
3. Heating Conditions, Compressor Operating at Max. Frequency	Indoor: 70°F DB/60°F WB Outdoor: 5°F DB/5°F WB

ELECTRICAL	
Power Supply	208/230V,60Hz,1Ph
System MCA	13
Connection Wiring	AWG 14-4
System MOCP	15
Compressor RLA	7.5
Outdoor Fan Motor RLA	0.4
Outdoor Fan Motor W	34
Indoor Fan Motor RLA	0.4
Indoor Fan Motor W	30
System Power Input @ Cooling (W)	1111(220 ~ 1430)
System Power Input @ Heating (W)	1053(235 ~1310)
MCA: Min. circuit amps (A)	MOCP: Max. over current protection (A)
RLA: Rated load amps (A)	W: Fan motor rated output (W)

PIPING	
Liquid Size	1/4in (6.35mm)
Gas Size	3/8in (9.52mm)
Drain Size	5/8in (15.88mm)
Max. Piping Length	82ft (25m)
Max. Height Difference	49.2ft (15m)
Max. Pre-charged Length	24.6ft (7.5m)
Refrigerant Pre-charged Amount	24.69oz (700g)
Additional Charge of Refrigerant	0.16oz/ft (15g/m)
Connection Method	Flared

Indoor Unit Dimension

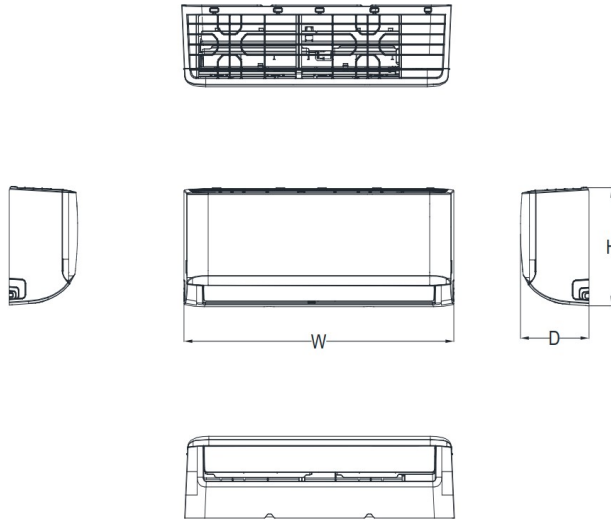

Capacity	Body Code	W(inch/mm)	D(mm/inch)	H(mm/inch)
6K~9K	A	28-3/4in /729mm	7-7/8in /200mm	11-1/2in /292mm
9K~12K	B	31-5/8in /802mm	7-7/8in /200mm	11-5/8in /295mm
18K	C	38-1/4in /971mm	9in/228mm	12-5/8in /321mm
18K~24K	D	42-5/8in /1082mm	9-1/4in/234mm	13-1/4in /337mm
30K~36K	F	49-5/8in /1259mm	11-1/8in/283mm	14-1/4in /362mm

Installation Instruction

1

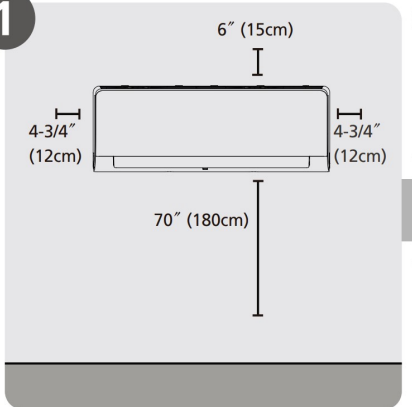

Select Installation Location

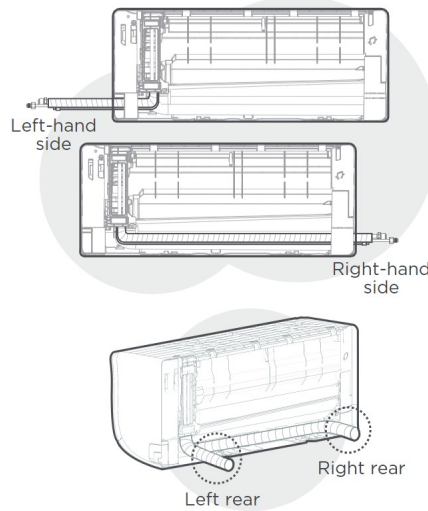

NOTE:
Based on the position of the wall hole relative to the mounting plate, choose the side from which the piping will exit the unit. You have four options for the exit direction of the piping.

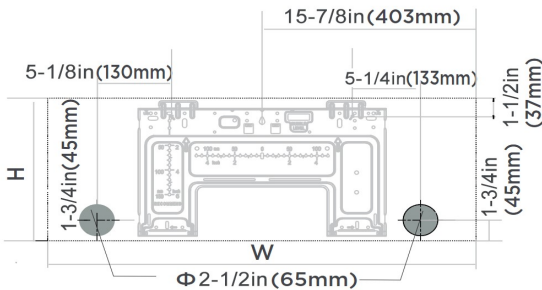

Indoor unit dimensions(WxH):
31-3/4in(806mm)x11-5/8in(296mm)

NOTE:
When the gas side connective pipe is Φ (5/8in)16mm or more, the wall hole should be (3-1/2in)90mm.

Outdoor Unit Dimension

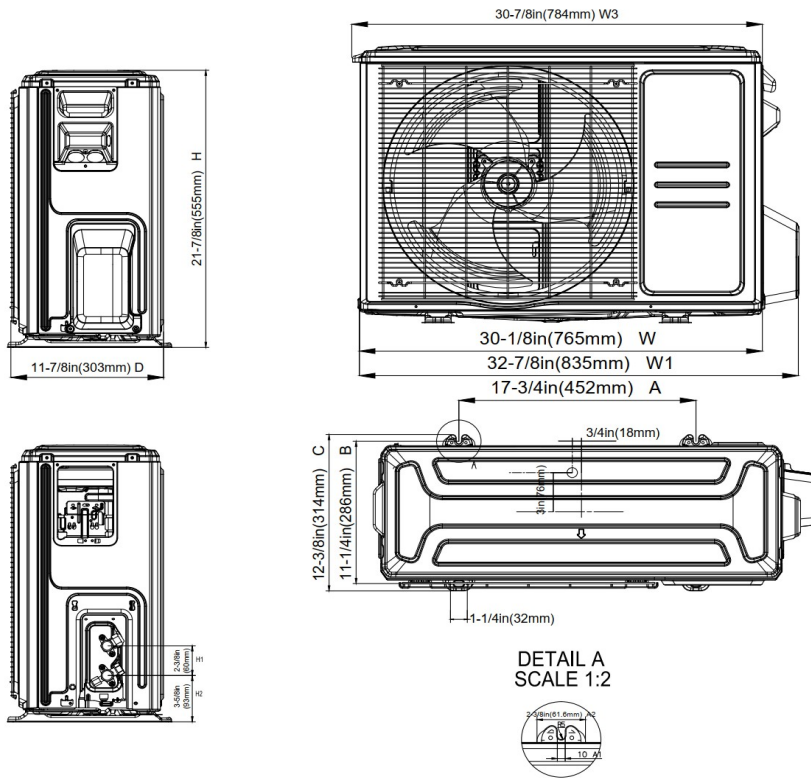

Installation Instruction

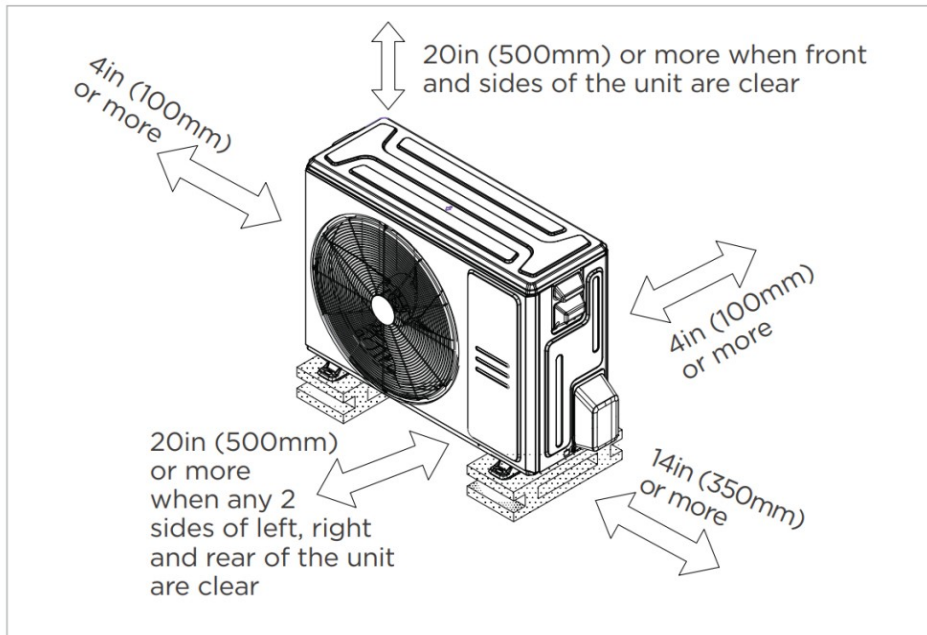

- Meets all special requirements shown in Installation Clearance Requirements above.

- Indoor unit use TU1 copper coil, better anti corrosion.
- 1~100% stepless adjustable fan speed setting
- WiFi capability: Built-in WiFi modular or wired controller with WiFi function
- OTA function: can upgrade the program version anytime
- Multiple controller options available:
 - Optional two way communication wired controller, programmable:120N(X6)
 - Optional two way communication wired controller, programmable, with built-in WiFi, :120N(X6W)
 - Optional Infrared wired controller: 120L
 - Standard Wireless remote controller RG10
 - Optional 24V interface kit, can connect with Third-Party 24V Thermostat