

# SUBMITTAL DATA SHEET



Series Name: **INNOVA 24V Mega Heat with AHU**  
 Model Number: **AUO18-24N1-M3H / AUH2-24N1-BM3E**

Heat Pump System	
Location: _____	Approval: _____
Engineer: _____	Date: _____
Submitted to: _____	Construction: _____
Submitted by: _____	Unit #: _____
Reference: _____	Drawing #: _____



INDOOR SPECIFICATION		
Indoor Air Flow (Turbo/H/M/L) (CFM)		824/759/694/629
Indoor Noise Level (H/M/L) (dBA)		39/36/33
Dimension (W×D×H)	inch	21 x 17-1/2 x 45
	mm	534 x 445 x 1143
Package (W×D×H)	inch	26-5/8 x 20-7/8 x 48-5/8
	mm	675 x 530 x 1235
Net/Gross Weight	lbs	106/127
	kg	47.9/57.8

OUTDOOR SPECIFICATION		
Compressor Type		Twin-ROTARY
Refrigerant		R410A
Factory Charge Oil		670ml
Refrigerant Oil		VG74
Outdoor Air Flow (Max) (CFM)		3000
Outdoor Noise Level (dBA)		62
Dimension (W×D×H)	inch	37-1/4 x 16-1/8 x 31-7/8
	mm	946 x 410 x 810
Package (W×D×H)	inch	42-7/8 x 19-5/8 x 34-7/8
	mm	1090 x 500 x 885
Net/Gross Weight	lbs	137/146
	kg	62/66

EFFICIENCY			
Cooling		Heating	
SEER2	17.4	HSPF2-4	10.0
EER2	11.7	COP	3.4
PERFORMANCE of Cooling			
Cooling (Btu/hr)			
Rated (Min/Max)		24000	
Sebsible @ AHRI		6400~27000	
Moisture Removal		1.98 L/H (4.18pint/H)	
Standard Operating Range		5°F~122°F (-15°C~50°C)	
Rated Cooling Conditions: Indoor: 80°F DB/67°F WB Outdoor: 95°F DB/75°F WB			
PERFORMANCE of Heating			
Heating (Btu/hr)			
1. @ 47°F Rated (Min/Max)		24000(10100~31000)	
2. @ 17°F Rated		19200	
3. @ 5°F Max: Capacity / COP		22600 / 1.91	
Standard Operating Range		-22°F~75°F (-30°C~24°C)	
1. Rated Heating Conditions: Indoor: 70°F DB/60°F WB Outdoor: 47°F DB/43°F WB			
2. Rated Heating Conditions: Indoor: 70°F DB/60°F WB Outdoor: 17°F DB/15°F WB			
3. Heating Conditions, Compressor Operating at Max. Frequency: Indoor: 70°F DB/60°F WB Outdoor: 5°F DB/5°F WB			

ELECTRICAL	
Power Supply	208/230V, 1Ph, 60Hz
Outdoor/Indoor MCA	20.5/4
Connection Wiring	AWG 14-2
Outdoor/Indoor MOC	30/15
Compressor RLA	15
Outdoor Fan Motor RLA	1.4
Outdoor Fan Motor W	120
Indoor Fan Motor RLA	3
Indoor Fan Motor W	/
System Power Input @ Cooling (W)	2050(740~2450)
System Power Input @ Heating (W)	2100(660~2900)
MCA: Min. circuit amps (A)	MOC: Max. over current protection (A)
RLA: Rated load amps (A)	W: Fan motor rated output (W)

PIPING	
Liquid Size	3/8in (9.52mm)
Gas Size	3/4in (19mm)
Drain Size	5/8in (15.88mm)
Max. Piping Length	164ft (50m)
Max. Height Difference	82ft (25m)
Max. Pre-charged Length	25ft (7.5m)
Refrigerant Pre-charged Amount	102.32oz (2901g)
Additional Charge of Refrigerant	0.69oz/ft (65g/m)
Connection Method	Flared

# Indoor Unit Dimension

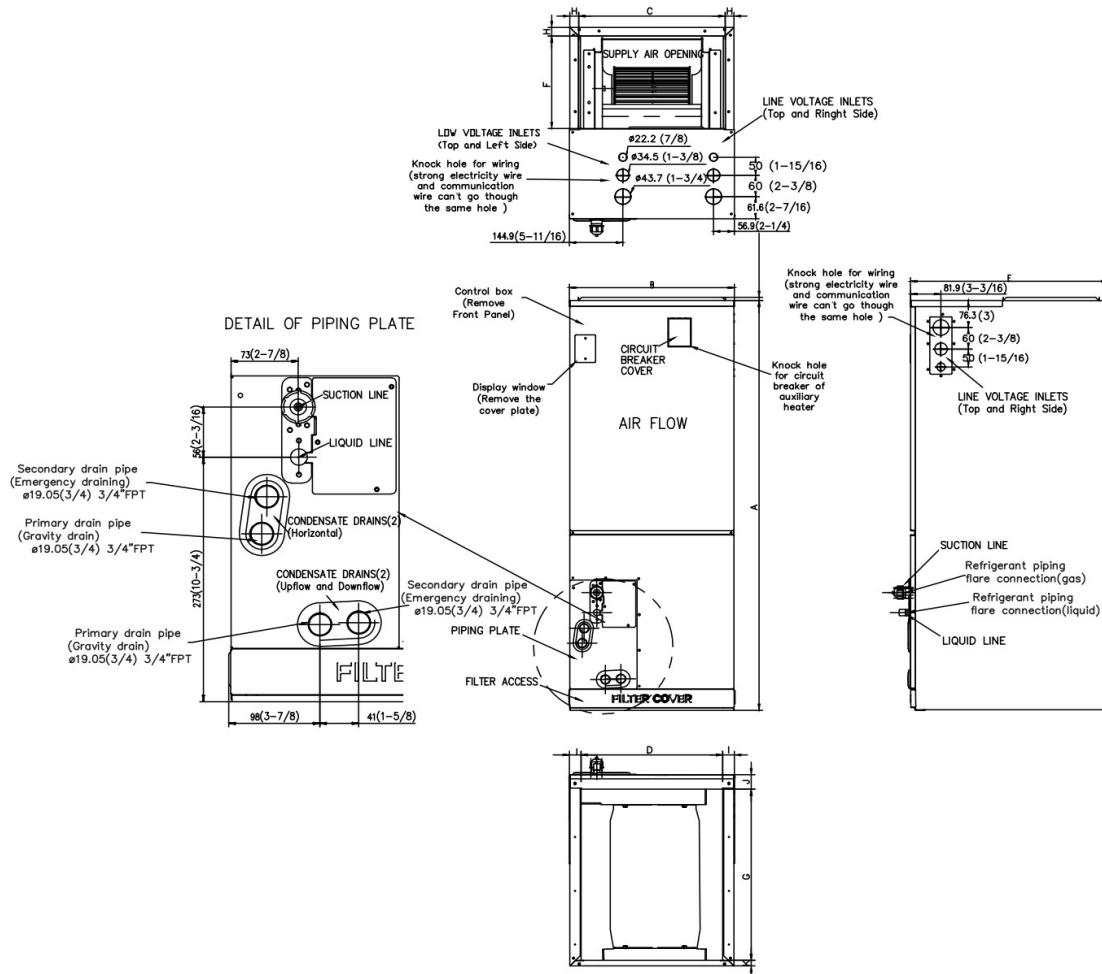

Dimensions	Model	18k/24k		30k/36k		48k/60k	
		inch	mm	inch	mm	inch	mm
A	Model Height	45	1143	49	1245	53	1346
B	Model Width	17-1/2	445	21	534	24-1/2	622
C	Supply Air Opening Width	15-5/8	397	19-1/8	486	22-5/8	575
D	Return Air Opening Width	15-1/8	384	18-5/8	473	22-1/8	562
E	Model Depth	21	534	21	534	21	534
F	Supply Air Opening Depth	10-1/4	260	10-1/4	260	10-1/4	260
G	Return Air Opening Depth	18-3/4	476	18-3/4	476	18-3/4	476
H	Supply Air Opening Clearance	15/16	24	15/16	24	15/16	24
I	Return Air Opening Side Clearance	1-1/4	32	1-1/4	32	1-1/8	28
J	Return Air Opening Front Clearance	1-1/2	38	1-5/8	41	1-5/8	41
K	Return Air Opening Back Clearance	5/8	16	5/8	16	3/4	19

**Outdoor Unit Dimension**

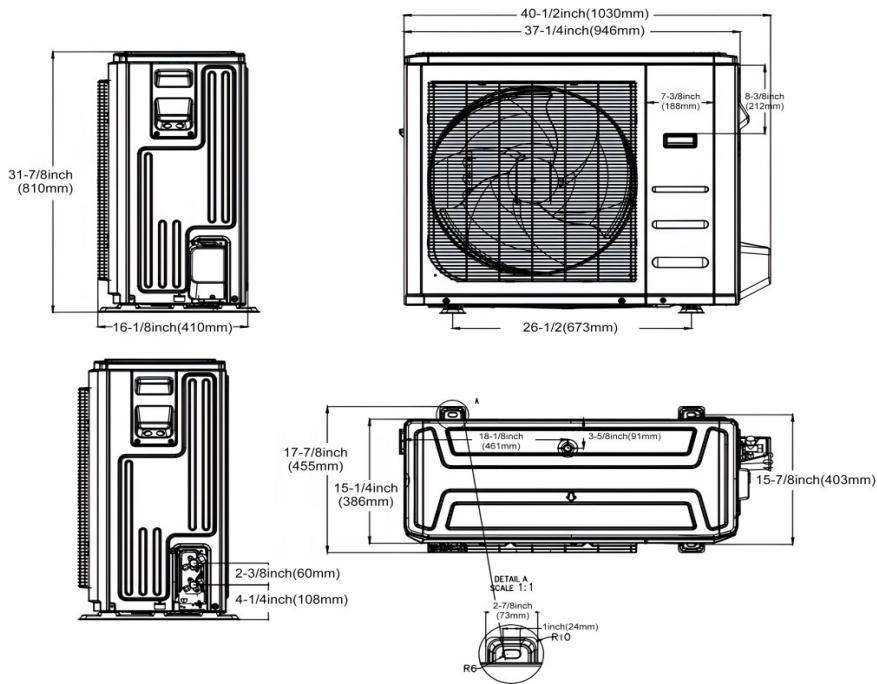

**Fan performance**

