

SUBMITTAL DATA SHEET



Series Name: INNOVA 24V Regular with AHU
Model Number: AUO17-60N1-M3 / AUH2-60N1-DM3E

Heat Pump System

Location: _____
 Engineer: _____
 Submitted to: _____
 Submitted by: _____
 Reference: _____

Approval: _____
 Date: _____
 Construction: _____
 Unit #: _____
 Drawing #: _____



INDOOR SPECIFICATION		
Indoor Air Flow (Turbo/H/M/L) (CFM)		1806/1582/1359/1135
Indoor Noise Level (H/M/L) (dBA)		52/48/43
Dimension (W×D×H)	inch	21 x 24-1/2 x 53
	mm	534 x 622 x 1346
Package (W×D×H)	inch	28 x 26-3/4 x 56-1/2
	mm	710 x 680 x 1435
Net/Gross Weight	lbs	163/193
	kg	73.8/87.5

OUTDOOR SPECIFICATION		
Compressor Type		ROTARY
Refrigerant		R410A
Factory Charge Oil		1400ml
Refrigerant Oil		VG74
Outdoor Air Flow (Max) (CFM)		4412
Outdoor Noise Level (dBA)		60
Dimension (W×D×H)	inch	37-1/2 x 16-3/8 x 52-1/2
	mm	952 x 415 x 1333
Package (W×D×H)	inch	43-1/8 x 19-1/2 x 58-1/4
	mm	1095 x 495 x 1480
Net/Gross Weight	lbs	217/248
	kg	98.5/112.7

EFFICIENCY			
Cooling		Heating	
SEER2	14.9	HSPF2-4	8.5
EER2	8.8	COP	3.5
PERFORMANCE of Cooling			
Cooling (Btu/hr)			
Rated Capacity		57000	
Min/Max Capacity		12800~60200	
Moisture Removal		5.2 L/H (11.0 pint/H)	
Standard Operating Range		5°F~122°F (-15°C~50°C)	
Rated Cooling Conditions: Indoor: 80°F DB/67°F WB Outdoor: 95°F DB/75°F WB			
PERFORMANCE of Heating			
Heating (Btu/hr)			
1. @ 47°F Rated (Min/Max)		60000(12000~63100)	
2. @ 17°F Rated		37000	
3. @ 5°F Max: Capacity / COP		34600 / 1.9	
Standard Operating Range		5°F~75°F (-15°C~24°C)	
1. Rated Heating Conditions: Indoor: 70°F DB/60°F WB Outdoor: 47°F DB/43°F WB			
2. Rated Heating Conditions: Indoor: 70°F DB/60°F WB Outdoor: 17°F DB/15°F WB			
3. Heating Conditions, Compressor Operating at Max. Frequency Indoor: 70°F DB/60°F WB Outdoor: 5°F DB/5°F WB			

ELECTRICAL	
Power Supply	208/230V, 1Ph, 60Hz
Outdoor/Indoor MCA	34/9
Connection Wiring	AWG 14-4
Outdoor/Indoor MOCP	40/15
Compressor RLA	24.6
Outdoor Fan Motor RLA	2.4
Outdoor Fan Motor W	85
Indoor Fan Motor RLA	7.0
Indoor Fan Motor W	/
System Power Input @ Cooling (W)	6475(700~6450)
System Power Input @ Heating (W)	5085(865~6086)
MCA: Min. circuit amps (A)	MOCP: Max. over current protection (A)
RLA: Rated load amps (A)	W: Fan motor rated output (W)

PIPING	
Liquid Size	3/8in (9.52mm)
Gas Size	7/8in (22mm)
Drain Size	5/8in (15.88mm)
Max. Piping Length	213.3ft (65m)
Max. Height Difference	98.4ft (30m)
Max. Pre-charged Length	25ft (7.5m)
Refrigerant Pre-charged Amount	172.84oz (4887g)
Additional Charge of Refrigerant	0.69oz/ft (65g/m)
Connection Method	Flared

Indoor Unit Dimension

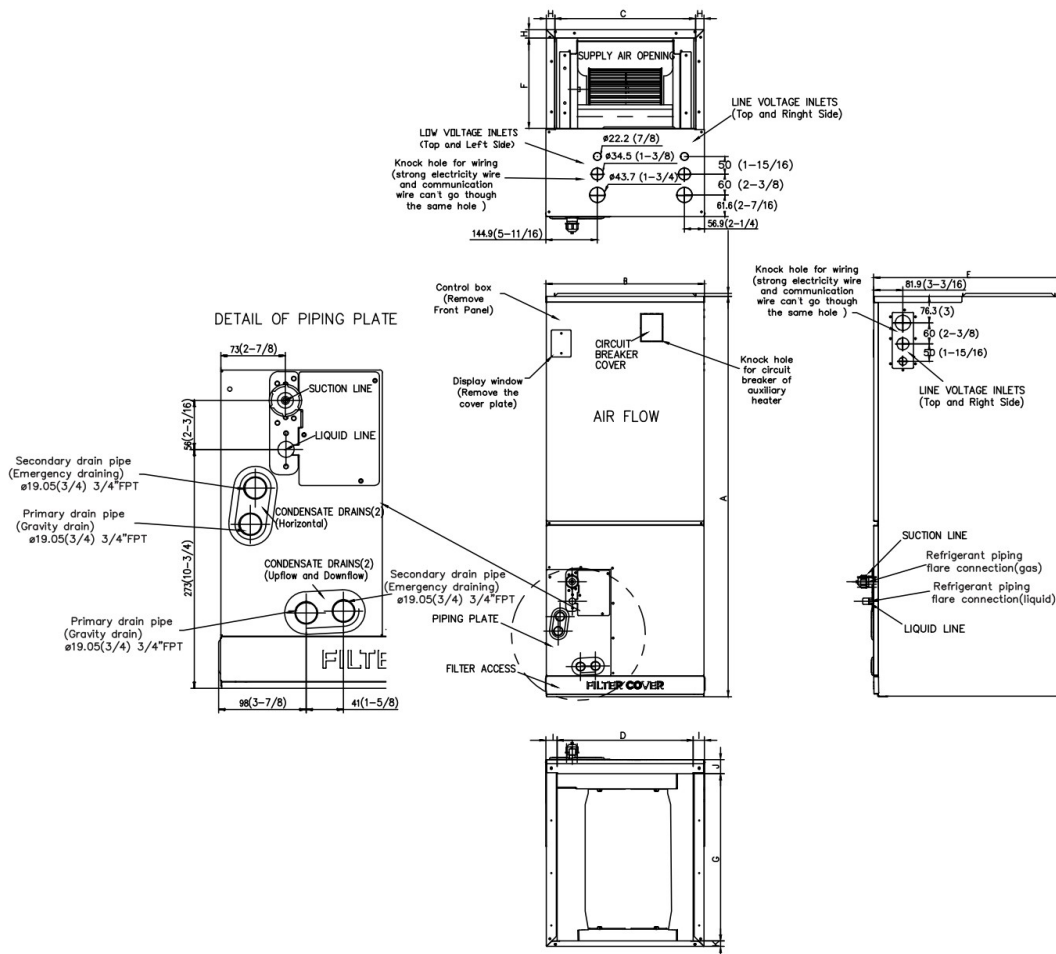

Dimensions	Model	18k/24k		30k/36k		48k/60k	
		inch	mm	inch	mm	inch	mm
A	Model Height	45	1143	49	1245	53	1346
B	Model Width	17-1/2	445	21	534	24-1/2	622
C	Supply Air Opening Width	15-5/8	397	19-1/8	486	22-5/8	575
D	Return Air Opening Width	15-1/8	384	18-5/8	473	22-1/8	562
E	Model Depth	21	534	21	534	21	534
F	Supply Air Opening Depth	10-1/4	260	10-1/4	260	10-1/4	260
G	Return Air Opening Depth	18-3/4	476	18-3/4	476	18-3/4	476
H	Supply Air Opening Clearance	15/16	24	15/16	24	15/16	24
I	Return Air Opening Side Clearance	1-1/4	32	1-1/4	32	1-1/8	28
J	Return Air Opening Front Clearance	1-1/2	38	1-5/8	41	1-5/8	41
K	Return Air Opening Back Clearance	5/8	16	5/8	16	3/4	19

Outdoor Unit Dimension

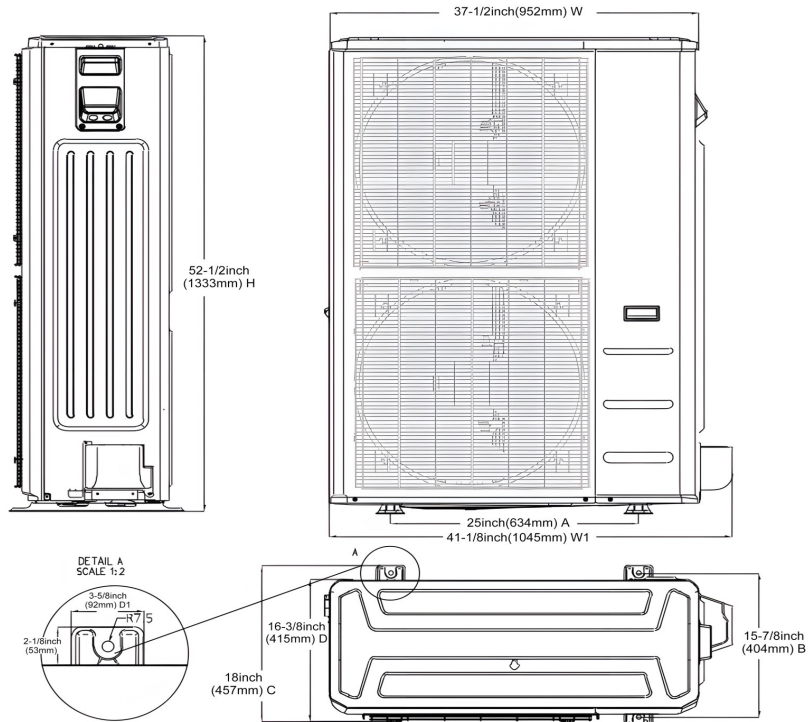

Fan Performance

