

SUBMITTAL DATA SHEET



Series Name: **INNOVA 24V Regular with AHU**
 Model Number: **AUO17-30N1-M3 / AUH2-30N1-CM3E**

Heat Pump System

Location: _____
 Engineer: _____
 Submitted to: _____
 Submitted by: _____
 Reference: _____

Approval: _____
 Date: _____
 Construction: _____
 Unit #: _____
 Drawing #: _____



INDOOR SPECIFICATION		
Indoor Air Flow (Turbo/H/M/L) (CFM)	988/894/806/712	
Indoor Noise Level (H/M/L) (dBA)	40.5/37.5/28	
Dimension (W×D×H)	inch	21 x 21 x 49
	mm	534 x 534 x 1245
Package (W×D×H)	inch	26-5/8 x 24-3/8 x 52-1/2
	mm	675 x 620 x 1335
Net/Gross Weight	lbs	129/156
	kg	58.6/70.6

OUTDOOR SPECIFICATION		
Compressor Type	ROTARY	
Refrigerant	R410A	
Factory Charge Oil	670ml	
Refrigerant Oil	VG74	
Outdoor Air Flow (Max) (CFM)	3000	
Outdoor Noise Level (dBA)	59.5	
Dimension (W×D×H)	inch	37-1/4 x 16-1/8 x 31-7/8
	mm	946 x 410 x 810
Package (W×D×H)	inch	42-7/8 x 19-5/8 x 34-7/8
	mm	1090 x 500 x 885
Net/Gross Weight	lbs	142/151
	kg	64.3/68.7

EFFICIENCY			
Cooling		Heating	
SEER2	17.3	HSPF2-4	8.5
EER2	10.6	COP	3.3
PERFORMANCE of Cooling			
Cooling (Btu/hr)			
Rated Capacity	30000		
Min/Max Capacity	9500~33000		
Moisture Removal	3.41 L/H (7.2 pint/H)		
Standard Operating Range	5°F~122°F (-15°C~50°C)		
Rated Cooling Conditions:		Indoor: 80°F DB/67°F WB Outdoor: 95°F DB/75°F WB	
PERFORMANCE of Heating			
Heating (Btu/hr)			
1. @ 47°F Rated (Min/Max)	31000(12200~32000)		
2. @ 17°F Rated	20000		
3. @ 5°F Max: Capacity / COP	17800 / 1.70		
Standard Operating Range	5°F~75°F (-15°C~24°C)		
1. Rated Heating Conditions:		Indoor: 70°F DB/60°F WB Outdoor: 47°F DB/43°F WB	
2. Rated Heating Conditions:		Indoor: 70°F DB/60°F WB Outdoor: 17°F DB/15°F WB	
3. Heating Conditions, Compressor Operating at Max. Frequency		Indoor: 70°F DB/60°F WB Outdoor: 5°F DB/5°F WB	

ELECTRICAL	
Power Supply	208/230V, 1Ph, 60Hz
Outdoor/Indoor MCA	20/4.5
Connection Wiring	AWG 14-4
Outdoor/Indoor MOC	20/15
Compressor RLA	16
Outdoor Fan Motor RLA	1.4
Outdoor Fan Motor W	120
Indoor Fan Motor RLA	3.5
Indoor Fan Motor W	/
System Power Input @ Cooling (W)	2835(720~3330)
System Power Input @ Heating (W)	2795(1000~2960)
MCA: Min. circuit amps (A)	MOC: Max. over current protection (A)
RLA: Rated load amps (A)	W: Fan motor rated output (W)

PIPING	
Liquid Size	3/8in (9.52mm)
Gas Size	3/4in (19mm)
Drain Size	5/8in (15.88mm)
Max. Piping Length	164ft (50m)
Max. Height Difference	82ft (25m)
Max. Pre-charged Length	25ft (7.5m)
Refrigerant Pre-charged Amount	107.59oz (3050g)
Additional Charge of Refrigerant	0.69oz/ft (65g/m)
Connection Method	Flared

Indoor Unit Dimension

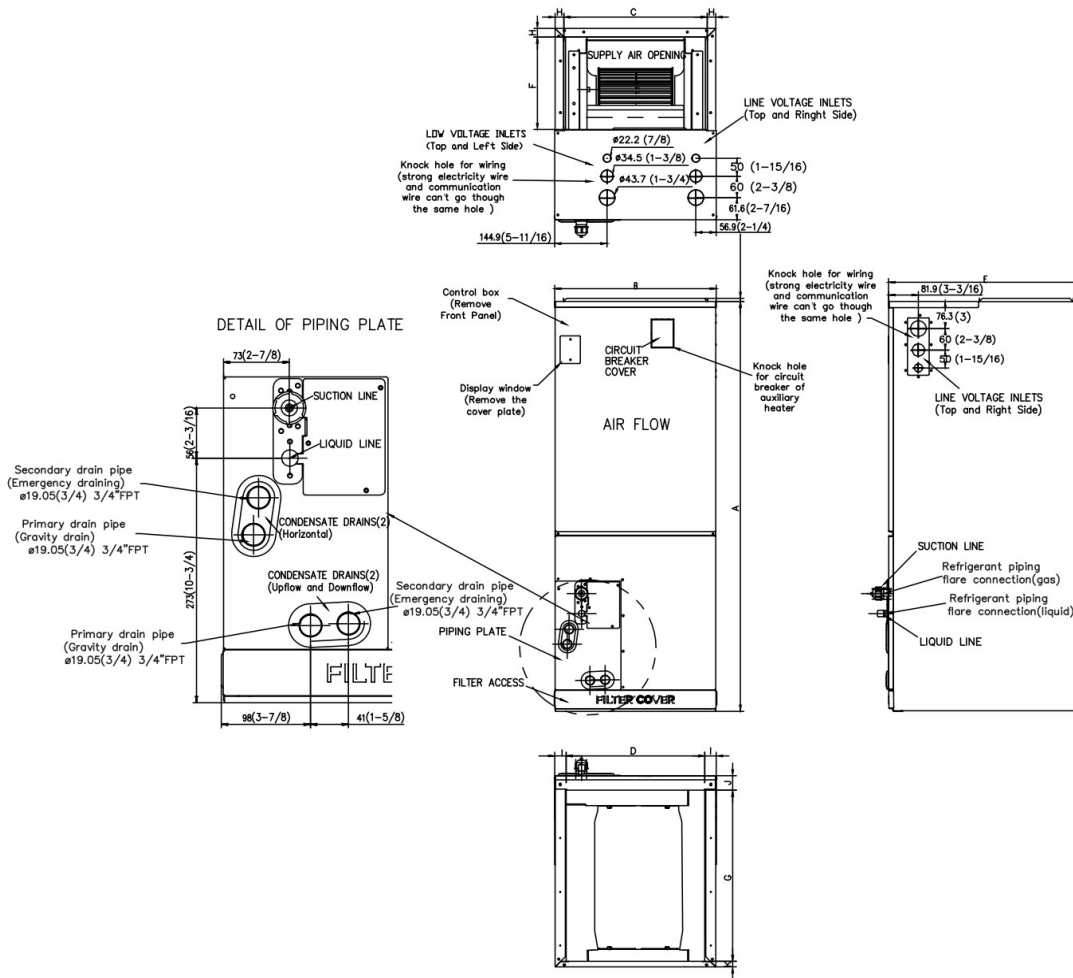

Dimensions	Model	18k/24k		30k/36k		48k/60k	
		inch	mm	inch	mm	inch	mm
A	Model Height	45	1143	49	1245	53	1346
B	Model Width	17-1/2	445	21	534	24-1/2	622
C	Supply Air Opening Width	15-5/8	397	19-1/8	486	22-5/8	575
D	Return Air Opening Width	15-1/8	384	18-5/8	473	22-1/8	562
E	Model Depth	21	534	21	534	21	534
F	Supply Air Opening Depth	10-1/4	260	10-1/4	260	10-1/4	260
G	Return Air Opening Depth	18-3/4	476	18-3/4	476	18-3/4	476
H	Supply Air Opening Clearance	15/16	24	15/16	24	15/16	24
I	Return Air Opening Side Clearance	1-1/4	32	1-1/4	32	1-1/8	28
J	Return Air Opening Front Clearance	1-1/2	38	1-5/8	41	1-5/8	41
K	Return Air Opening Back Clearance	5/8	16	5/8	16	3/4	19

Outdoor Unit Dimension

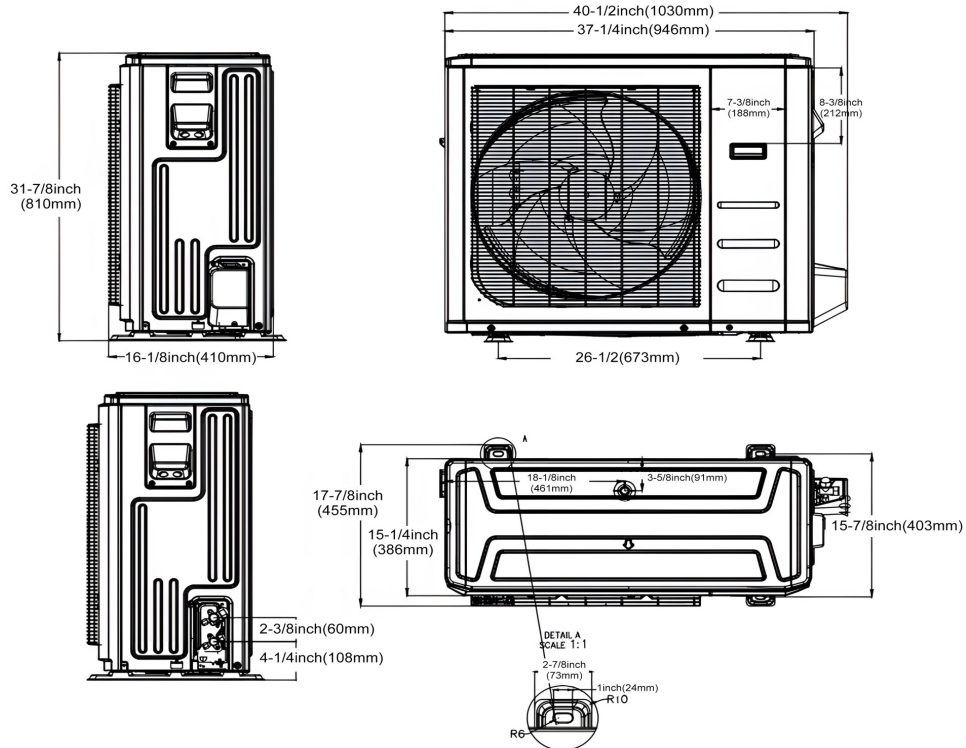

Fan Performance

