

SUBMITTAL DATA SHEET



Series Name: **Multi Zone Mega Heat Series**

Model Number: **A5MO22-55N1-M1H**

Heat Pump System	
Location: _____	Approval: _____
Engineer: _____	Date: _____
Submitted to: _____	Construction: _____
Submitted by: _____	Unit #: _____
Reference: _____	Drawing #: _____



OUTDOOR SPECIFICATION		
Compressor Type	ROTARY	
Refrigerant	R410A	
Factory Charge Oil	1460±15ml	
Refrigerant Oil	VG74	
Outdoor Air Flow (Max) (CFM)	4500	
Outdoor Noise Level (dBA)	62	
Dimension (WxDxH)	inch	37-1/2 x 16-3/8 x 52-1/2
	mm	952 x 415 x 1333
Package (WxDxH)	inch	43-1/8 x 19-1/2 x 58-1/4
	mm	1095 x 495 x 1480
Net/Gross Weight	lbs	238/270
	kg	108.1/122.4

EFFICIENCY			
Cooling		Heating	
SEER2	20	HSPF2-4	9.3
EER2	10.5	COP	3.2
PERFORMANCE of Cooling			
Cooling (Btu/hr)			
Rated (Min/Max)		55000	
Sebsible @ AHRI		11600~56500	
Moisture Removal		/	
Standard Operating Range		5°F~122°F (-15°C~50°C)	
Rated Cooling Conditions: Indoor: 80°F DB/67°F WB Outdoor: 95°F DB/75°F WB			
PERFORMANCE of Heating			
Heating (Btu/hr)			
1. @ 47°F Rated (Min/Max)		55000(33000~63000)	
2. @ 17°F Rated		34800	
3. @ 5°F Max: Capacity / COP		45500 / 1.8	
Standard Operating Range		-22°F~75°F (-30°C~24°C)	
1. Rated Heating Conditions: Indoor: 70°F DB/60°F WB Outdoor: 47°F DB/43°F WB			
2. Rated Heating Conditions: Indoor: 70°F DB/60°F WB Outdoor: 17°F DB/15°F WB			
3. Heating Conditions, Compressor Operating at Max. Frequency Indoor: 70°F DB/60°F WB Outdoor: 5°F DB/5°F WB			

ELECTRICAL	
Power Supply	208/230V, 1Ph, 60Hz
System MCA	40
Connection Wiring	AWG 14-4
System MOCP	60
Compressor RLA	25
Outdoor Fan Motor RLA	2.5
Outdoor Fan Motor W	85
Indoor Fan Motor RLA	/
Indoor Fan Motor W	/
System Power Input @ Cooling (W)	5238(810~5800)
System Power Input @ Heating (W)	5117(2860~5650)
MCA: Min. circuit amps (A)	MOCP: Max. over current protection (A)
RLA: Rated load amps (A)	W: Fan motor rated output (W)

PIPING	
Liquid Size	5x1/4in (5x6.35mm)
Gas Size	3x3/8+2x1/2in (3x9.52+2x12.7mm)
Max. Piping Length for all rooms	262.5ft (80m)
Max. Piping Length for one IDU	114.8ft (35m)
Max. Height Difference of IDU and ODU	49.2ft (15m)
Refrigerant Pre-charged Amount	162.3oz (4601g)
Refrigearent Precharge Length	25x5 (ft)
Additional Charge of Refrigerant (Φ6.35 (1/4") liquid pipe)	0.16oz/ft (15g/m)
Additional Charge of Refrigerant (Φ9.52 (3/8") liquid pipe)	0.32oz/ft (30g/m)
Connection Method	Flared

Outdoor Unit Dimension

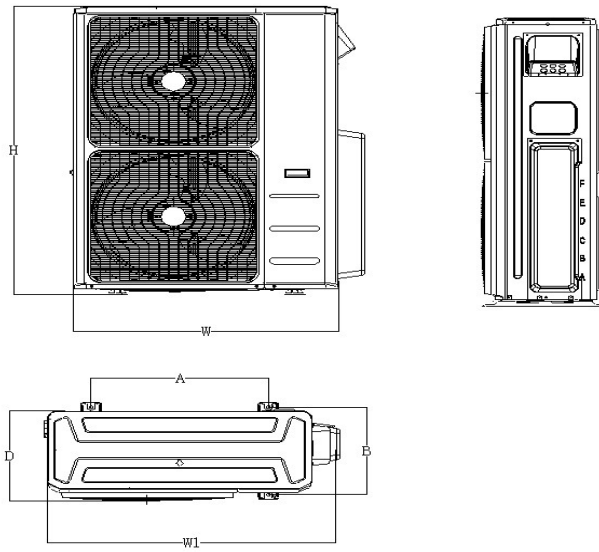

Unit ^①	W ^②	D ^②	H ^②	W1 ^②	A ^②	B ^②
mm ^②	952 ^②	415 ^②	1333 ^②	1060 ^②	634 ^②	404 ^②
inch ^②	37.5 ^②	16.3 ^②	52.5 ^②	41.7 ^②	25.0 ^②	15.9 ^②

Installation Instruction

REQUIRED CLEARANCE

*1 20in. (500mm) or more when front and sides of the unit are clear

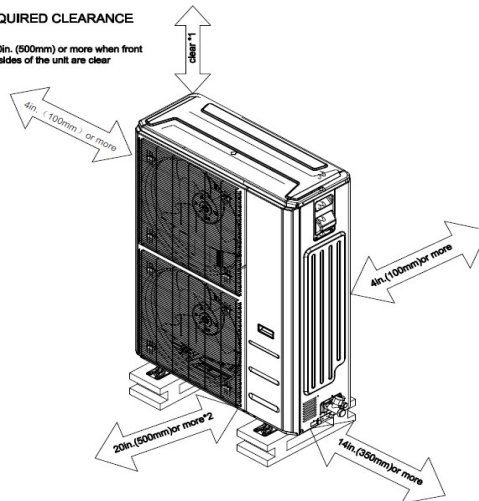

*2 When any 2 sides of left, right and rear of the unit are clear