

SUBMITTAL DATA SHEET



Series Name: INNOVA 24V Mega Heat with Wall Mounted AHU

Model Number: AUO18-24N1-M3H / AUE-24N1-MM3E

Heat Pump System	
Location: _____	Approval: _____
Engineer: _____	Date: _____
Submitted to: _____	Construction: _____
Submitted by: _____	Unit #: _____
Reference: _____	Drawing #: _____



INDOOR SPECIFICATION		
Indoor Air Flow (H/M/L) (CFM)		824/759/694
Indoor Noise Level (H/M/L) (dBA)		51/47/45
Dimension (W×D×H)	inch	20-1/4 x 15-3/4 x 36-1/2
	mm	515 x 399 x 928
Package (W×D×H)	inch	22-7/8 x 19-1/2 x 42-7/8
	mm	580 x 495 x 1090
Net/Gross Weight	lbs	88/109
	kg	40/49.5

OUTDOOR SPECIFICATION		
Compressor Type		Twin-ROTARY
Refrigerant		R410A
Factory Charge Oil		670ml
Refrigerant Oil		VG74
Outdoor Air Flow (Max) (CFM)		3000
Outdoor Noise Level (dBA)		62
Dimension (W×D×H)	inch	37-1/4 x 16-1/8 x 31-7/8
	mm	946 x 410 x 810
Package (W×D×H)	inch	42-7/8 x 19-5/8 x 34-7/8
	mm	1090 x 500 x 885
Net/Gross Weight	lbs	137/146
	kg	62/66

EFFICIENCY			
Cooling		Heating	
SEER2	17.5	HSPF2-4	10.5
EER2	11.7	COP	3.7
PERFORMANCE of Cooling			
Cooling (Btu/hr)			
Rated (Min/Max)		24000	
Sebsible @ AHRI		8900~27000	
Moisture Removal		2.39L/H (5.04pint/H)	
Standard Operating Range		5°F~122°F (-15°C~50°C)	
Rated Cooling Conditions: Indoor: 80°F DB/67°F WB Outdoor: 95°F DB/75°F WB			
PERFORMANCE of Heating			
Heating (Btu/hr)			
1. @ 47°F Rated (Min/Max)		26000(7000~32400)	
2. @ 17°F Rated		19400	
3. @ 5°F Max: Capacity / COP		24000 / 2	
Standard Operating Range		-22°F~75°F (-30°C~24°C)	
1. Rated Heating Conditions: Indoor: 70°F DB/60°F WB Outdoor: 47°F DB/43°F WB			
2. Rated Heating Conditions: Indoor: 70°F DB/60°F WB Outdoor: 17°F DB/15°F WB			
3. Heating Conditions, Compressor Operating at Max. Frequency: Indoor: 70°F DB/60°F WB Outdoor: 5°F DB/5°F WB			

ELECTRICAL	
Power Supply	208/230V, 1Ph, 60Hz
Outdoor/Indoor MCA	20.5/4.5
Connection Wiring	AWG 14-2
Outdoor/Indoor MOCP	35/15
Compressor RLA	15
Outdoor Fan Motor RLA	1.4
Outdoor Fan Motor W	120
Indoor Fan Motor RLA	3.5
Indoor Fan Motor W	/
System Power Input @ Cooling (W)	2050(468~2690)
System Power Input @ Heating (W)	2087(445~2850)
MCA: Min. circuit amps (A)	MOCP: Max. over current protection (A)
RLA: Rated load amps (A)	W: Fan motor rated output (W)

PIPING	
Liquid Size	3/8in (9.52mm)
Gas Size	3/4 in(19mm) ODU Adaptor from 5/8 to 3/4
Drain Size	5/8in (15.88mm)
Max. Piping Length	164ft (50m)
Max. Height Difference	82ft (25m)
Max. Pre-charged Length	25ft (7.5m)
Refrigerant Pre-charged Amount	102.32oz (2901g)
Additional Charge of Refrigerant	0.69oz/ft (65g/m)
Connection Method	Flared

Indoor Unit Dimension

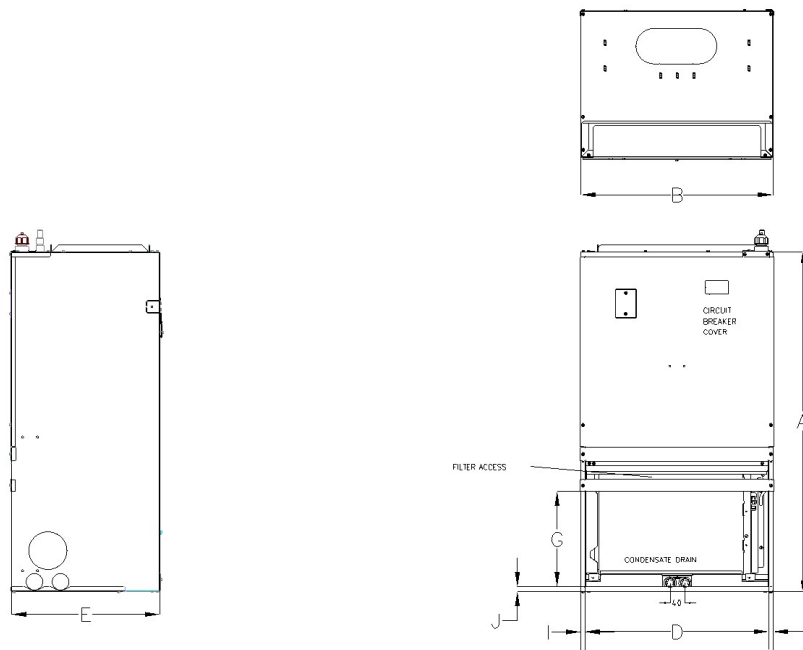

Dimensions	Model(Btu/h)	18K/24K		30K/36K	
		inch	mm	inch	mm
A	Model Height	36.5	928	49	1017
B	Model Width	20.3	515	21	559
C	Supply Air Opening Width	17.4	442	18.8	478.6
D	Return Air Opening Width	19.4	493.8	21.2	537.8
E	Model Depth	15.7	399	21	483
F	Supply Air Opening Depth	10.4	265.2	9.3	235.4
G	Return Air Opening Depth	10.3	261	13.1	332.5
H	Supply Air Opening Clearance	1.1	29.1	1.6	41
I	Return Air Opening Side Clearance	0.42	10.6	0.42	10.6
J	Return Air Opening Front Clearance	0.47	12	0.63	16

Outdoor Unit Dimension

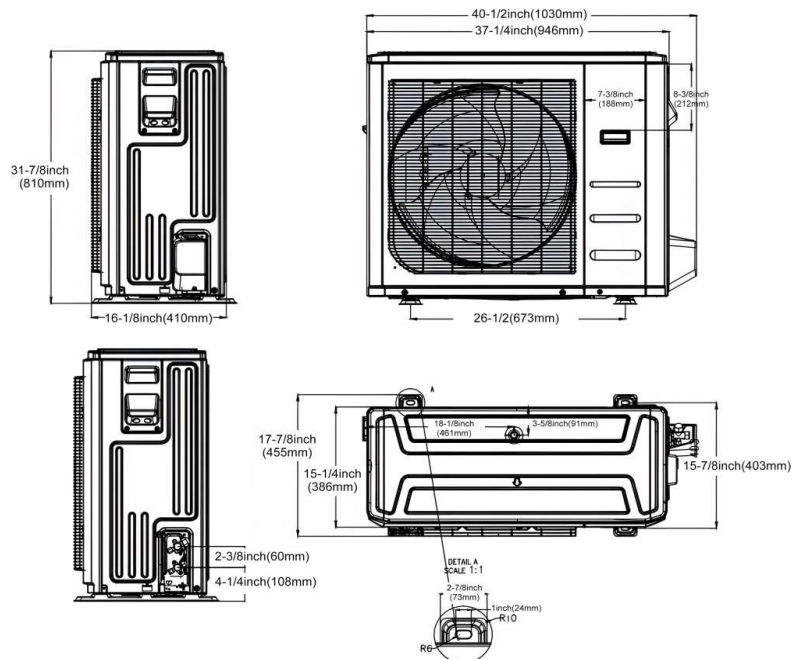

Fan performance

