

SUBMITTAL DATA SHEET



Series Name: **INNOVA 24V Regular with Wall Mounted AHU**

Model Number: **AUO17-36N1-M3 / AUE-36N1-LM3E**

Heat Pump System	
Location: _____	Approval: _____
Engineer: _____	Date: _____
Submitted to: _____	Construction: _____
Submitted by: _____	Unit #: _____
Reference: _____	Drawing #: _____



INDOOR SPECIFICATION		
Indoor Air Flow (H/M/L) (CFM)		1188/1082/971
Indoor Noise Level (H/M/L) (dBA)		58/52/49
Dimension (W×D×H)	inch	22 x 19 x 40
	mm	559 x 483 x 1017
Package (W×D×H)	inch	24-5/8 x 22-7/8 x 47
	mm	625 x 580 x 1193
Net/Gross Weight	lbs	109/133
	kg	49.4/60.3

OUTDOOR SPECIFICATION		
Compressor Type		ROTARY
Refrigerant		R410A
Factory Charge Oil		670ml
Refrigerant Oil		VG74
Outdoor Air Flow (Max) (CFM)		2235
Outdoor Noise Level (dBA)		63
Dimension (W×D×H)	inch	37-1/4 x 16-1/8 x 31-7/8
	mm	946 x 410 x 810
Package (W×D×H)	inch	42-7/8 x 19-5/8 x 34-7/8
	mm	1090 x 500 x 885
Net/Gross Weight	lbs	152/161
	kg	68.8/73.1

EFFICIENCY			
Cooling		Heating	
SEER2	16.9	HSPF2-4	8.0
EER2	10.0	COP	3.2
PERFORMANCE of Cooling			
Cooling (Btu/hr)			
Rated Capacity		35000	
Min/Max Capacity		10000~36000	
Moisture Removal		4.05 L/H (8.5 pint/H)	
Standard Operating Range		5°F~122°F (-15°C~50°C)	
Rated Cooling Conditions: Indoor: 80°F DB/67°F WB Outdoor: 95°F DB/75°F WB			
PERFORMANCE of Heating			
Heating (Btu/hr)			
1. @ 47°F Rated (Min/Max)		36000(8500~36600)	
2. @ 17°F Rated		19000	
3. @ 5°F Max: Capacity / COP		21500 / 1.92	
Standard Operating Range		-13°F~75°F (-25°C~24°C)	
1. Rated Heating Conditions: Indoor: 70°F DB/60°F WB Outdoor: 47°F DB/43°F WB			
2. Rated Heating Conditions: Indoor: 70°F DB/60°F WB Outdoor: 17°F DB/15°F WB			
3. Heating Conditions, Compressor Operating at Max. Frequency: Indoor: 70°F DB/60°F WB Outdoor: 5°F DB/5°F WB			

ELECTRICAL	
Power Supply	208/230V, 1Ph, 60Hz
Outdoor/Indoor MCA	24/6.5
Connection Wiring	AWG 14-4
Outdoor/Indoor MOCP	40/15
Compressor RLA	17.6
Outdoor Fan Motor RLA	1.5
Outdoor Fan Motor W	120
Indoor Fan Motor RLA	4.0
Indoor Fan Motor W	/
System Power Input @ Cooling (W)	3500(480~4340)
System Power Input @ Heating (W)	3253(440~3210)
MCA: Min. circuit amps (A)	MOCP: Max. over current protection (A)
RLA: Rated load amps (A)	W: Fan motor rated output (W)

PIPING	
Liquid Size	3/8in (9.52mm)
Gas Size	3/4in (19mm)
Drain Size	5/8in (15.88mm)
Max. Piping Length	213.3ft (65m)
Max. Height Difference	98.4ft (30m)
Max. Pre-charged Length	25ft (7.5m)
Refrigerant Pre-charged Amount	130.51oz (3700g)
Additional Charge of Refrigerant	0.69oz/ft (65g/m)
Connection Method	Flared

Indoor Unit Dimension

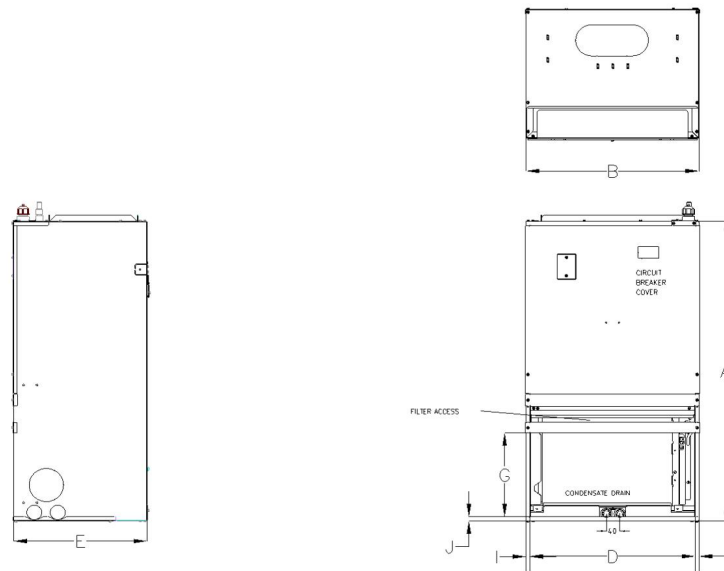

Dimensions		Model(Btu/h)		18K/24K		30K/36K	
		inch	mm	inch	mm		
A	Model Height	36.5	928	49	1017		
B	Model Width	20.3	515	21	539		
C	Supply Air Opening Width	17.4	442	18.8	478.6		
D	Return Air Opening Width	19.4	493.8	21.2	537.8		
E	Model Depth	15.7	399	21	483		
F	Supply Air Opening Depth	10.4	265.2	9.3	235.4		
G	Return Air Opening Depth	10.3	261	13.1	332.5		
H	Supply Air Opening Clearance	1.1	29.1	1.6	41		
I	Return Air Opening Side Clearance	0.42	10.6	0.42	10.6		
J	Return Air Opening Front Clearance	0.47	12	0.63	16		

Outdoor Unit Dimension

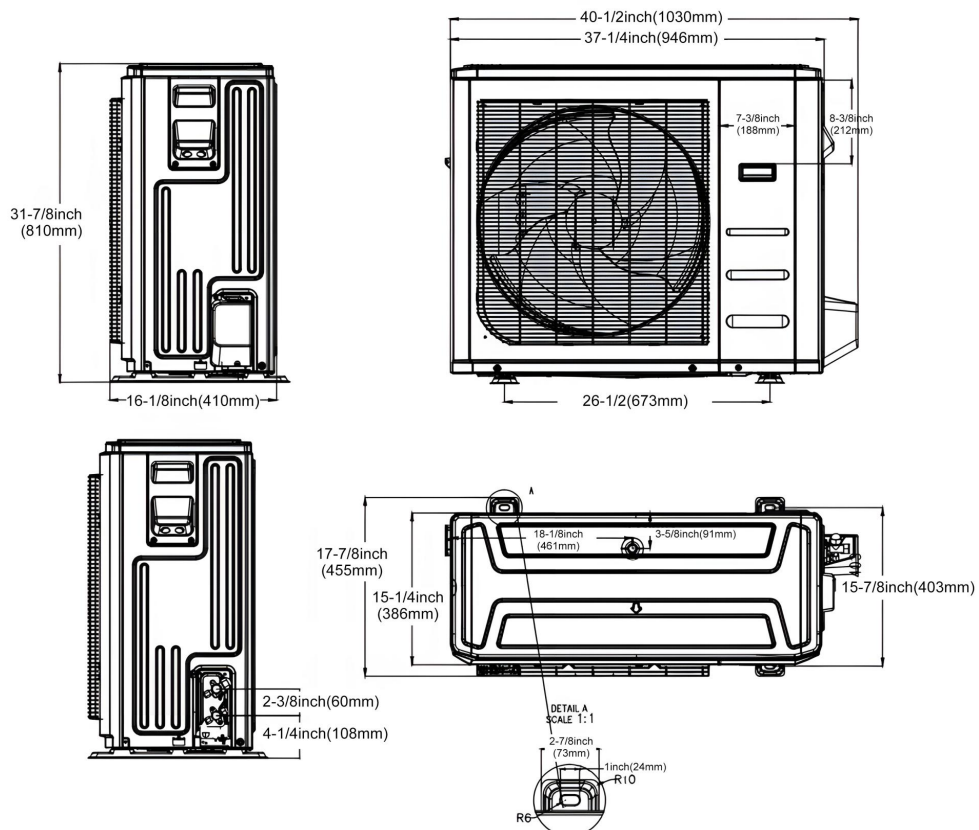

Fan Performance

