

SUBMITTAL DATA SHEET



Series Name: **INNOVA 24V Regular with Pancake**

Model Number: **AUO17-36N1-M3 / AUP-36N1-KM3**

Heat Pump System	
Location: _____	Approval: _____
Engineer: _____	Date: _____
Submitted to: _____	Construction: _____
Submitted by: _____	Unit #: _____
Reference: _____	Drawing #: _____



INDOOR SPECIFICATION		
Indoor Air Flow (H/M/L) (CFM)		1176/1000/794
Indoor Noise Level (H/M/L) (dBA)		60/56/53
Dimension (W×D×H)	inch	62-1/8 x 23-3/8 x 11
	mm	1578 x 593 x 278
Package (W×D×H)	inch	66-1/8 x 26-3/4 x 13-5/8
	mm	1680 x 680 x 345
Net/Gross Weight	lbs	145/157
	kg	65.7/71.1

OUTDOOR SPECIFICATION		
Compressor Type		ROTARY
Refrigerant		R410A
Factory Charge Oil		670ml
Refrigerant Oil		VG74
Outdoor Air Flow (Max) (CFM)		2235
Outdoor Noise Level (dBA)		63
Dimension (W×D×H)	inch	37-1/4 x 16-1/8 x 31-7/8
	mm	946 x 410 x 810
Package (W×D×H)	inch	42-7/8 x 19-5/8 x 34-7/8
	mm	1090 x 500 x 885
Net/Gross Weight	lbs	152/161
	kg	68.8/73.1

EFFICIENCY			
Cooling		Heating	
SEER2	16.0	HSPF2-4	8.0
EER2	9.5	COP	To be confirmed
PERFORMANCE of Cooling			
Cooling (Btu/hr)			
Rated Capacity		36000	
Min/Max Capacity		To be confirmed	
Moisture Removal		To be confirmed	
Standard Operating Range		5°F~122°F (-15°C~50°C)	
Rated Cooling Conditions:		Indoor: 80°F DB/67°F WB Outdoor: 95°F DB/75°F WB	
PERFORMANCE of Heating			
Heating (Btu/hr)			
1. @ 47°F Rated (Min/Max)		36000	
2. @ 17°F Rated		19000	
3. @ 5°F Max: Capacity / COP		20000 / 1.80	
Standard Operating Range		-13°F~75°F (-25°C~24°C)	
1. Rated Heating Conditions:		Indoor: 70°F DB/60°F WB Outdoor: 47°F DB/43°F WB	
2. Rated Heating Conditions:		Indoor: 70°F DB/60°F WB Outdoor: 17°F DB/15°F WB	
3. Heating Conditions, Compressor Operating at Max. Frequency		Indoor: 70°F DB/60°F WB Outdoor: 5°F DB/5°F WB	

ELECTRICAL	
Power Supply	208/230V, 1Ph, 60Hz
Outdoor/Indoor MCA	24/5
Connection Wiring	AWG 14-4
Outdoor/Indoor MOCP	40/15
Compressor RLA	17.6
Outdoor Fan Motor RLA	1.5
Outdoor Fan Motor W	To be confirmed
Indoor Fan Motor RLA	4.0
Indoor Fan Motor W	To be confirmed
System Power Input @ Cooling (W)	To be confirmed
System Power Input @ Heating (W)	To be confirmed
MCA: Min. circuit amps (A)	MOCP: Max. over current protection (A)
RLA: Rated load amps (A)	W: Fan motor rated output (W)

PIPING	
Liquid Size	3/8in (9.52mm)
Gas Size	3/4in (19mm)
Drain Size	5/8in (15.88mm)
Max. Piping Length	213.3ft (65m)
Max. Height Difference	98.4ft (30m)
Max. Pre-charged Length	25ft (7.5m)
Refrigerant Pre-charged Amount	130.51oz (3700g)
Additional Charge of Refrigerant	0.69oz/ft (65g/m)
Connection Method	Flared

Indoor Unit Dimension

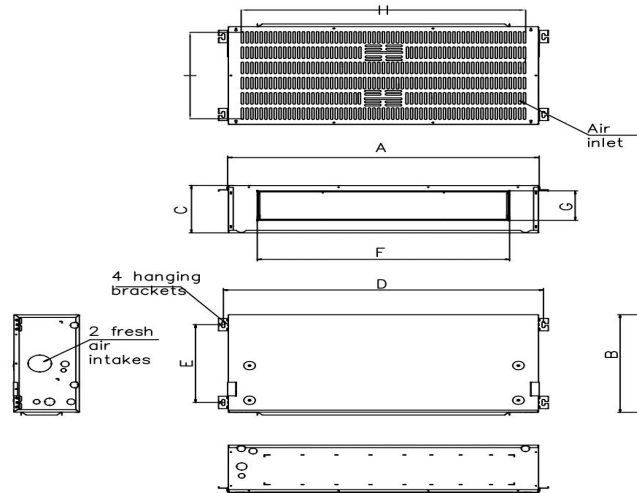

Dimensions		Model(Btu/h)	18K inch	24K inch	30K inch	36K inch
A	Model Length		43-1/4	49-1/8	55-1/4	62-1/8
B	Model Width		23-5/16	23-5/16	23-5/16	23-5/16
C	Model Height		10-15/16	10-15/16	10-15/16	10-15/16
D	MOUNTED LUG Length		41-5/8	47-1/2	53-5/8	60-1/2
E	MOUNTED LUG width		18-1/8	18-1/8	18-1/8	18-1/8
F	AIR OUTLET LENGTH		30-5/16	36-3/16	42-5/16	49-3/16
G	AIR OUTLET WIDTH		6-7/8	6-7/8	6-7/8	6-7/8
H	AIR RETURN LENGTH		38-3/8	44-5/16	50-3/8	57-1/4
I	AIR RETURN WIDTH		21-1/8	21-1/8	21-1/8	21-1/8

Outdoor Unit Dimension

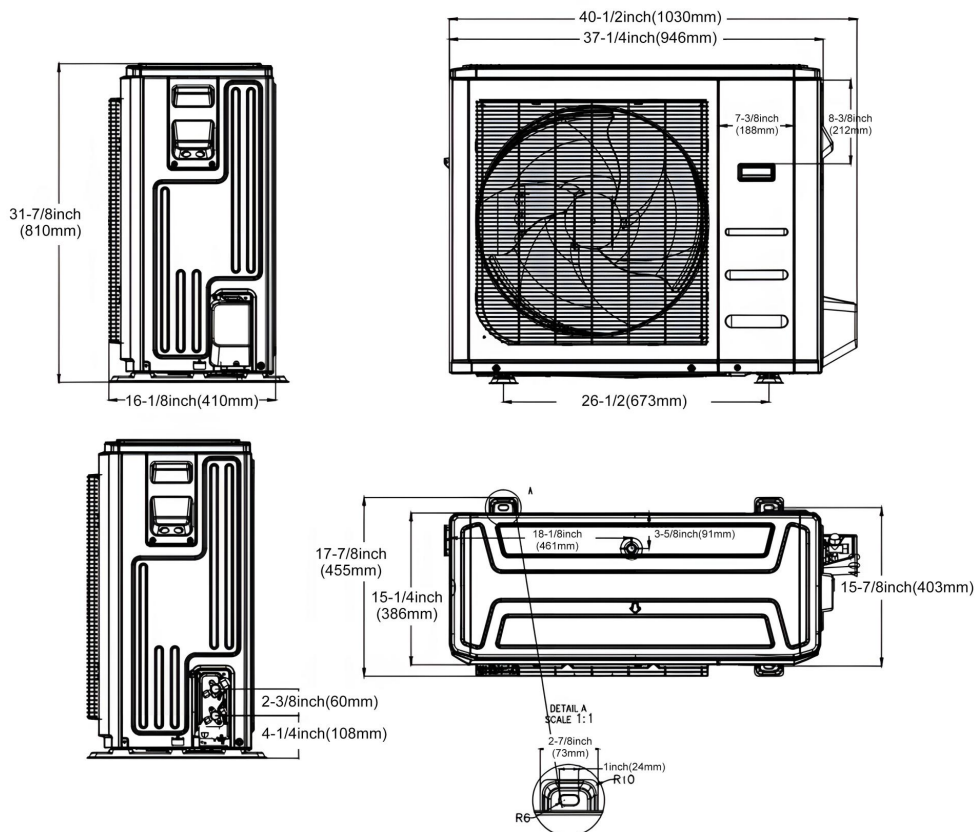

36K

