

SUBMITTAL DATA SHEET



Series Name: Mini Split 29seer Series
Model Number: AQ29-24N1-M1H / AW29-24N1-M1

Wall Mounted Heat Pump System

Location: _____
 Engineer: _____
 Submitted to: _____
 Submitted by: _____
 Reference: _____

Approval: _____
 Date: _____
 Construction: _____
 Unit #: _____
 Drawing #: _____



INDOOR SPECIFICATION		
Indoor Air Flow (H/M/L) (CFM)		719/611/414
Indoor Noise Level (H/M/L) (dBA)		46/39/34
Dimension (W×D×H)	inch	46-7/8 x 11-1/4 x 14-5/8
	mm	1190 x 284.6 x 370.6
Package (W×D×H)	inch	50-3/8 x 14-1/8 x 17-7/8
	mm	1280 x 360 x 455
Net/Gross Weight	lbs	44/55
	kg	19.8/24.9

OUTDOOR SPECIFICATION		
Compressor Type	Twin-ROTARY	
Refrigerant	R410A	
Factory Charge	620ml	
Refrigerant Oil	VG74	
Outdoor Air Flow (Max) (CFM)	2235	
Outdoor Noise Level (dBA)	62	
Dimension (W×D×H)	inch	37-1/4 x 16-1/8 x 31-7/8
	mm	946 x 410 x 810
Package (W×D×H)	inch	42-7/8 x 19-5/8 x 34-7/8
	mm	1090 x 500 x 885
Net/Gross Weight	lbs	134/144
	kg	61/65.5

EFFICIENCY			
Cooling		Heating	
SEER2	21.5	HSPF2-4	11.4
EER2	13	COP	3.4
PERFORMANCE of Cooling			
Cooling (Btu/hr)			
Rated (Min/Max)		24000	
Sebsible @ AHRI		6850~27000	
Moisture Removal		2.6L/H (5.5pint/H)	
Standard Operating Range		-22°F~-122°F (-30°C~50°C)	
Rated Cooling Conditions:			
		Indoor: 80°F DB/67°F WB	
		Outdoor: 95°F DB/75°F WB	
PERFORMANCE of Heating			
Heating (Btu/hr)			
1. @ 47°F Rated (Min/Max)		29000(11600~33000)	
2. @ 17°F Rated		21200	
3. @ 5°F Max: Capacity / COP		25000 / 2.21	
Standard Operating Range		-22°F~75°F (-30°C~24°C)	
1. Rated Heating Conditions:			
		Indoor: 70°F DB/60°F WB	
		Outdoor: 47°F DB/43°F WB	
2. Rated Heating Conditions:			
		Indoor: 70°F DB/60°F WB	
		Outdoor: 17°F DB/15°F WB	
3. Heating Conditions, Compressor			
		Indoor: 70°F DB/60°F WB	
Operating at Max. Frequency			
		Outdoor: 5°F DB/5°F WB	

ELECTRICAL	
Power Supply	208/230V,1Ph,60Hz
System MCA	25
Connection Wiring	AWG 14-4
System MOCP	30
Compressor RLA	17.1
Outdoor Fan Motor RLA	0.5
Outdoor Fan Motor W	120
Indoor Fan Motor RLA	0.5
Indoor Fan Motor W	58
System Power Input @ Cooling (W)	1845(310~2400)
System Power Input @ Heating (W)	2500(670~3000)
MCA: Min. circuit amps (A)	MOCP: Max. over current protection (A)
RLA: Rated load amps (A)	W: Fan motor rated output (W)

PIPING	
Liquid Size	3/8in (9.52mm)
Gas Size	5/8in (15.9mm)
Drain Size	5/8in (15.88mm)
Max. Piping Length	164ft (50m)
Max. Height Difference	82ft (25m)
Max. Pre-charged Length	25ft (7.5m)
Refrigerant Pre-charged Amount	91.71oz (2600g)
Additional Charge of Refrigerant	0.32oz/ft (30g/m)
Connection Method	Flared

Indoor Unit Dimension

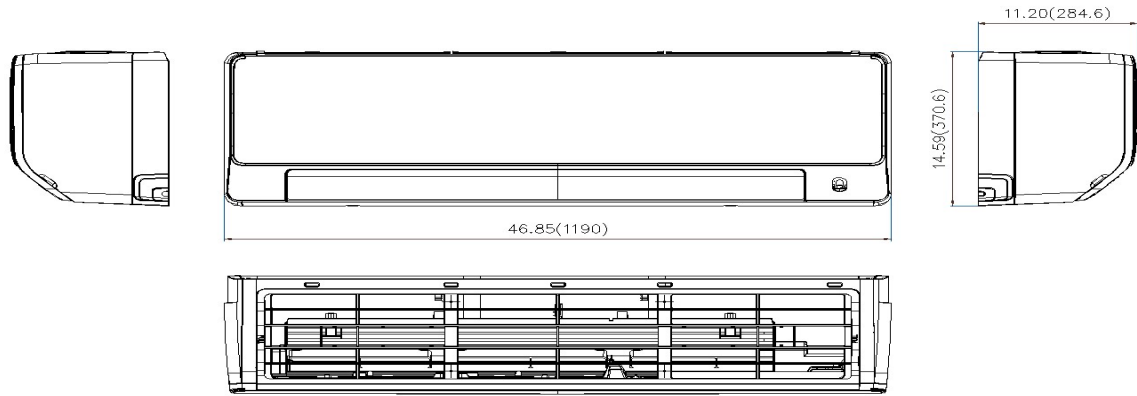

Installation Instruction

Refer to the following diagram to ensure proper distance from walls and ceiling:

Distance from ceiling is determined by the installation method.

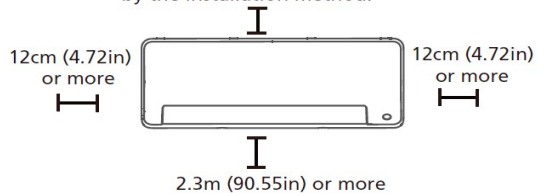

NOTE ON PIPING ANGLE

Refrigerant piping can exit the indoor unit from four different angles: Left-hand side, Right-hand side, Left rear, Right rear.

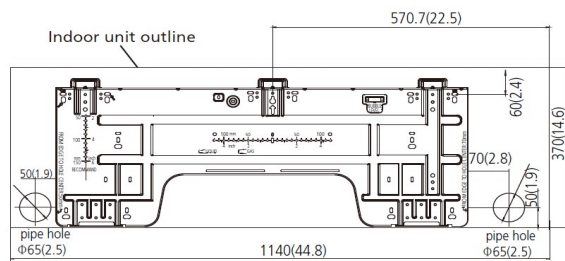
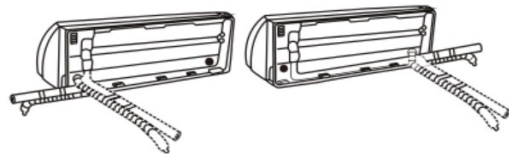

Model C

NOTE: When the gas side connective pipe is $\Phi 16\text{mm} (5/8\text{in})$ or more, the wall hole should be $90\text{mm} (3.54\text{in})$.

Outdoor Unit Dimension

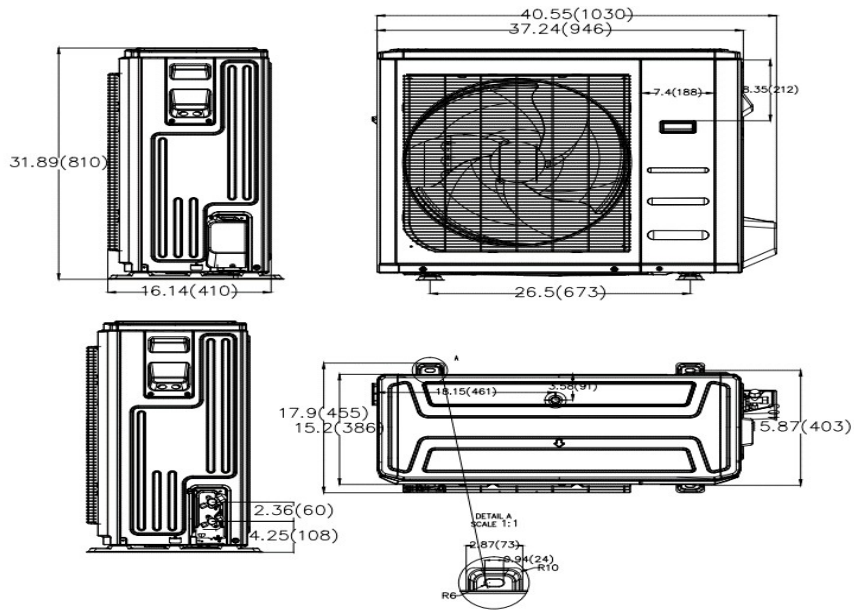

Installation Instruction

Install the unit by following local codes and regulations, there may be differ slightly between different regions.

