

SUBMITTAL DATA SHEET



Series Name: **Mini Split 25seer Series**

Model Number: **AO25-12N1-M1H / AW25-12N1-M1**

Wall Mounted Heat Pump System	
Location: _____	Approval: _____
Engineer: _____	Date: _____
Submitted to: _____	Construction: _____
Submitted by: _____	Unit #: _____
Reference: _____	Drawing #: _____



INDOOR SPECIFICATION		
Indoor Air Flow (H/M/L) (CFM)		341/291/194
Indoor Noise Level (H/M/L) (dBA)		41.5/36/24
Dimension (WxDxH)	inch	31-5/8 x 7-7/8 x 11-5/8
	mm	802 x 200 x 295
Package (WxDxH)	inch	34-1/2 x 11-1/4 x 15
	mm	875 x 285 x 380
Net/Gross Weight	lbs	19/24
	kg	8.5/11

OUTDOOR SPECIFICATION		
Compressor Type		ROTARY
Refrigerant		R410A
Factory Charge		350ml
Refrigerant Oil		VG74
Outdoor Air Flow (Max) (CFM)		1324
Outdoor Noise Level (dBA)		56
Dimension (WxDxH)	inch	31-3/4 x 13 x 21-3/4
	mm	805 x 330 x 554
Package (WxDxH)	inch	36 x 14-5/8 x 24-1/4
	mm	915 x 370 x 615
Net/Gross Weight	lbs	74/79
	kg	33.4/36

EFFICIENCY			
Cooling		Heating	
SEER2	23.1	HSPF2-4	10.5
EER2	13.0	COP	3.6
PERFORMANCE of Cooling			
Cooling (Btu/hr)			
Rated Capacity		12000	
Min/Max Capacity		3700~13300	
Moisture Removal		1.45 L/H (3.1pint/H)	
Standard Operating Range		-22°F~-122°F (-30°C~50°C)	
Rated Cooling Conditions:		Indoor: 80°F DB/67°F WB Outdoor: 95°F DB/75°F WB	
PERFORMANCE of Heating			
Heating (Btu/hr)			
1. @ 47°F Rated (Min/Max)		12000(5100~14300)	
2. @ 17°F Rated		10300	
3. @ 5°F Max: Capacity / COP		11000 / 1.88	
Standard Operating Range		-22°F~-75°F (-30°C~24°C)	
1. Rated Heating Conditions:		Indoor: 70°F DB/60°F WB Outdoor: 47°F DB/43°F WB	
2. Rated Heating Conditions:		Indoor: 70°F DB/60°F WB Outdoor: 17°F DB/15°F WB	
3. Heating Conditions, Compressor Operating at Max. Frequency		Indoor: 70°F DB/60°F WB Outdoor: 5°F DB/5°F WB	

ELECTRICAL	
Power Supply	208/230V, 1Ph, 60Hz
System MCA	15
Connection Wiring	AWG 14-4
System MOCP	15
Compressor RLA	8.8
Outdoor Fan Motor RLA	0.4
Outdoor Fan Motor W	34
Indoor Fan Motor RLA	0.4
Indoor Fan Motor W	13
System Power Input @ Cooling (W)	923(200~1150)
System Power Input @ Heating (W)	978(350~1400)
MCA: Min. circuit amps (A)	MOCP: Max. over current protection (A)
RLA: Rated load amps (A)	W: Fan motor rated output (W)

PIPING	
Liquid Size	1/4in (6.35mm)
Gas Size	1/2in (12.7mm)
Drain Size	5/8in (15.88mm)
Max. Piping Length	82ft (25m)
Max. Height Difference	32.8ft (10m)
Max. Pre-charged Length	25ft (7.5m)
Refrigerant Pre-charged Amount	41.62oz (1180g)
Additional Charge of Refrigerant	0.16oz/ft (15g/m)
Connection Method	Flared

Indoor Unit Dimension

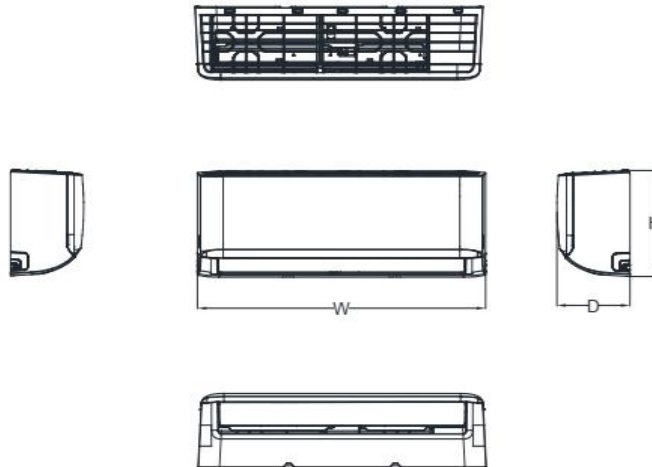

Capacity	Body Code	W(mm/inch)	D(mm/inch)	H(mm/inch)
6K~11K	A	729/28.7	200/7.87	292/11.5
8K~14K	B	802/31.57	200/7.87	295/11.61
12K~21K	C	971/38.23	228/8.98	321/12.64
18K~28K	D	1082/42.6	234/9.21	337/13.27
27K~36K	F	1259/49.57	283/11.14	362/14.25

Installation Instruction

Refer to the following diagram to ensure proper distance from walls and ceiling:

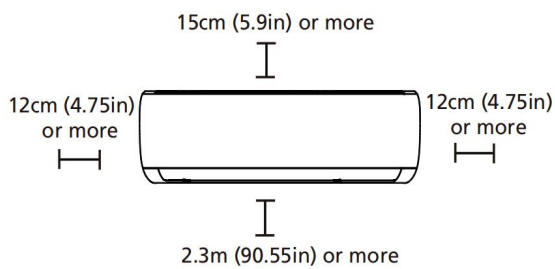

NOTE ON PIPING ANGLE

Refrigerant piping can exit the indoor unit from four different angles: Left-hand side, Right-hand side, Left rear, Right rear.

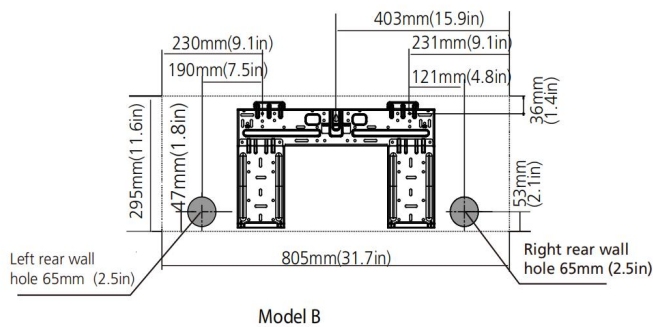
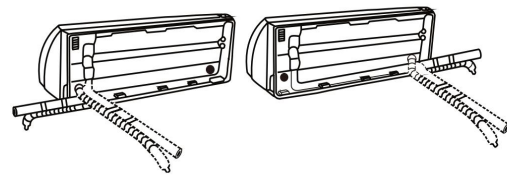

NOTE: When the gas side connective pipe is Φ 16mm (5/8in) or more, the wall hole should be 90mm (3.54in).

Outdoor Unit Dimension

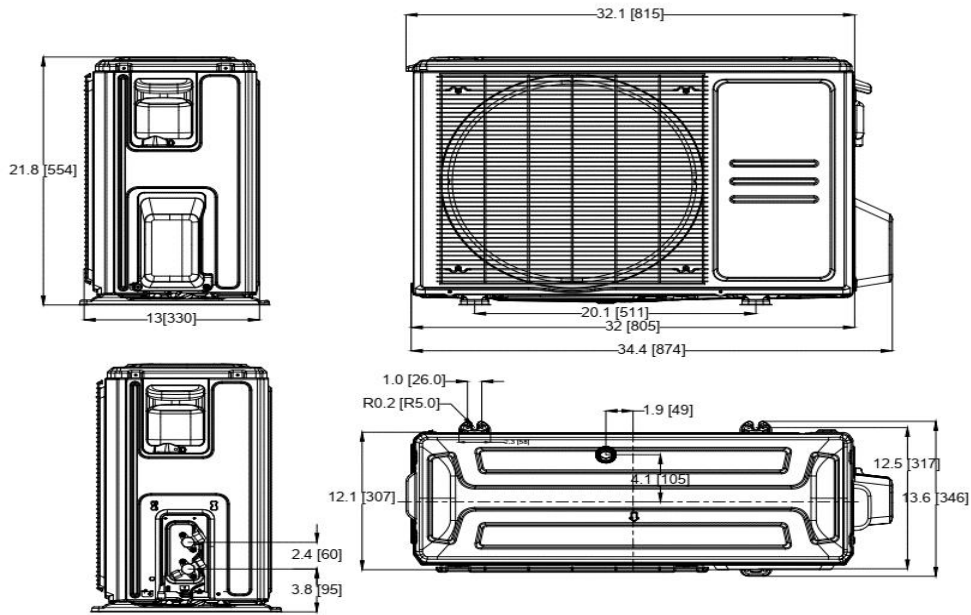

Installation Instruction

Install the unit by following local codes and regulations, there may be differ slightly between different regions.

